

3.2 Light

01. 0625_s20_qp_61 Q: 3

A student investigates the position of the image in a plane mirror.

Fig. 3.1 shows the ray-trace sheet he uses.



Fig. 3.1

3.2. LIGHT

- (a)
- The student draws the line **MR**.
 - He draws a normal **NL** to this line that passes through the centre of **MR**.
 - He labels the point at which **NL** crosses **MR** with the letter **B**.
 - He draws a line from **B** at an angle of incidence $i = 30^\circ$ to the normal below **MR** and to the left of the normal. He labels the end of this line **A**.
 - He places a pin P_1 on line **AB**, as shown in Fig. 3.1. He places another pin P_2 on the line **AB**.
 - He places the reflecting face of the mirror vertically on the line **MR**.
 - He views the images of pins P_1 and P_2 from the direction indicated by the eye in Fig. 3.1.
- (i) On Fig. 3.1, mark with a cross a suitable position for pin P_2 in this experiment. [1]
- He places two pins P_3 and P_4 some distance apart so that pin P_3 and the images of P_2 and P_1 all appear exactly behind pin P_4 . The positions of P_3 and P_4 are shown on Fig. 3.1.
- (ii) Draw the line joining the positions of P_3 and P_4 . Continue the line until it extends at least 7.0 cm beyond **MR**. [2]
- (b)
- The student keeps pin P_1 in the same position but moves pin P_2 so that the angle of incidence $i = 40^\circ$.
 - The pin positions P_5 and P_6 for the reflected ray are marked on Fig. 3.1.
- (i) Draw the line joining the positions of P_5 and P_6 . Continue the line until it extends at least 7.0 cm beyond **MR**.
- Label with the letter **Y** the point where the two lines cross beyond **MR**. [1]
- (ii) Draw a line from P_1 to **MR** that meets **MR** at a right angle. Measure and record the length a of this line.
- Paper Perfection, Crafted With Passion..... [1]
- $a = \dots\dots\dots$
- (iii) Draw a line from the point labelled **Y** to **MR** that meets **MR** at a right angle. Measure and record the length b of this line.
- $b = \dots\dots\dots$ [1]

- (c)
- The student removes all the pins. He places pin P_7 on the normal at a distance 6.0 cm from the front of the mirror.
 - He views the image of P_7 in the mirror.
 - He places pin P_8 on the normal behind the mirror.
 - He adjusts the position of P_8 so that the image of the bottom of the pin P_7 and the top of pin P_8 seen over the mirror appear as one pin when viewed from all angles in front of the mirror.
- (i) On Fig. 3.1, measure the distance x along the normal between P_8 and the mirror.

$x = \dots\dots\dots$ [1]

- (ii) Complete the diagram in Fig. 3.2 to show the appearance of the image of pin P_7 and pin P_8 as described in (c).



Fig. 3.2

[1]

- (d) The student expects the readings to show that the image formed in a plane mirror is the same distance behind the mirror as the object is in front of the mirror. Readings of $a = b$ and $x = 6.0$ cm will show this.

State whether your readings show that the image formed in a plane mirror is the same distance behind the mirror as the object is in front of the mirror. Justify your statement by reference to the readings.

statement

justification

..... [2]

- (e) The student carries out this experiment with care. Suggest a practical reason why the results may not be accurate.

.....

..... [1]

[Total: 11]

3.2. LIGHT

02. 0625_s20_qp_63 Q: 3

A student determines the focal length of a converging lens. She uses the apparatus shown in Fig. 3.1.

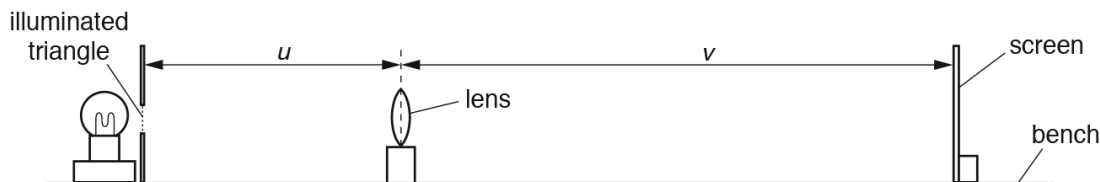

Fig. 3.1

Method 1

(a) The student sets the distance U between the illuminated triangle and the lens. She moves the screen until a sharp image of the triangle is seen on the screen.

(i) On Fig. 3.1, measure the distance u between the illuminated triangle and the lens.

$u = \dots\dots\dots$

On Fig. 3.1, measure the distance v between the lens and the screen.

$v = \dots\dots\dots$

[1]

(ii) Fig. 3.1 is drawn to 1/5th scale.

Calculate the actual distance U between the illuminated triangle and the lens in the experiment.

$U = \dots\dots\dots$

Calculate the actual distance V between the lens and the screen in the experiment.

$V = \dots\dots\dots$

[1]

(iii) Calculate a value f_1 for the focal length of the lens. Use the equation

$$f_1 = \frac{UV}{(U + V)}$$

$f_1 = \dots\dots\dots$ [1]

- (iv) Briefly describe a technique to obtain an image on the screen that is as sharp as possible in this experiment.

.....

 [1]



Fig. 3.2

Method 2

- (b) The student keeps the screen in the same position.

She moves the lens closer to the screen, as shown in Fig. 3.2, until another sharp image of the triangle is seen on the screen.

- (i) Measure the distance v between the lens and the screen as indicated in Fig. 3.2.

$v =$

Fig. 3.2 is drawn to $1/5^{\text{th}}$ scale.

Calculate the actual distance V between the lens and the screen in the experiment.

$V =$

[1]

3.2. LIGHT

- (ii) The illuminated triangle and its image are shown full size in Fig. 3.3 and Fig. 3.4.

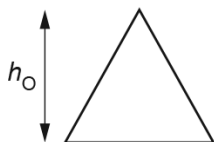

Fig. 3.3



Fig. 3.4

Measure h_0 , the height of the illuminated triangle, as shown in Fig. 3.3.

$h_0 = \dots\dots\dots$

Measure h_1 , the height of the image on the screen, as shown in Fig. 3.4.

$h_1 = \dots\dots\dots$ [1]

- (iii) Calculate a value for the magnification M using the equation $M = \frac{h_1}{h_0}$.

$M = \dots\dots\dots$ [1]

- (iv) Calculate a second value f_2 for the focal length of the lens using the equation $f_2 = \frac{V}{(M + 1)}$ and the value of V from (b)(i).

$f_2 = \dots\dots\dots$ [1]

- (c) State **one** precaution the student must take to ensure that the **measurements** of U and V in this experiment are as reliable as possible.

..... [1]

- (d) (i) Explain why **Method 2** is likely to produce a less accurate value for the focal length than **Method 1**.

..... [1]

- (ii) Suggest **one** improvement to make **Method 2** more accurate.

..... [1]

[Total: 11]

03. 0625_m19_qp_62 Q: 1

A student is investigating the reflection of light by a plane mirror.

Fig. 1.1 shows his ray-trace sheet at full size.

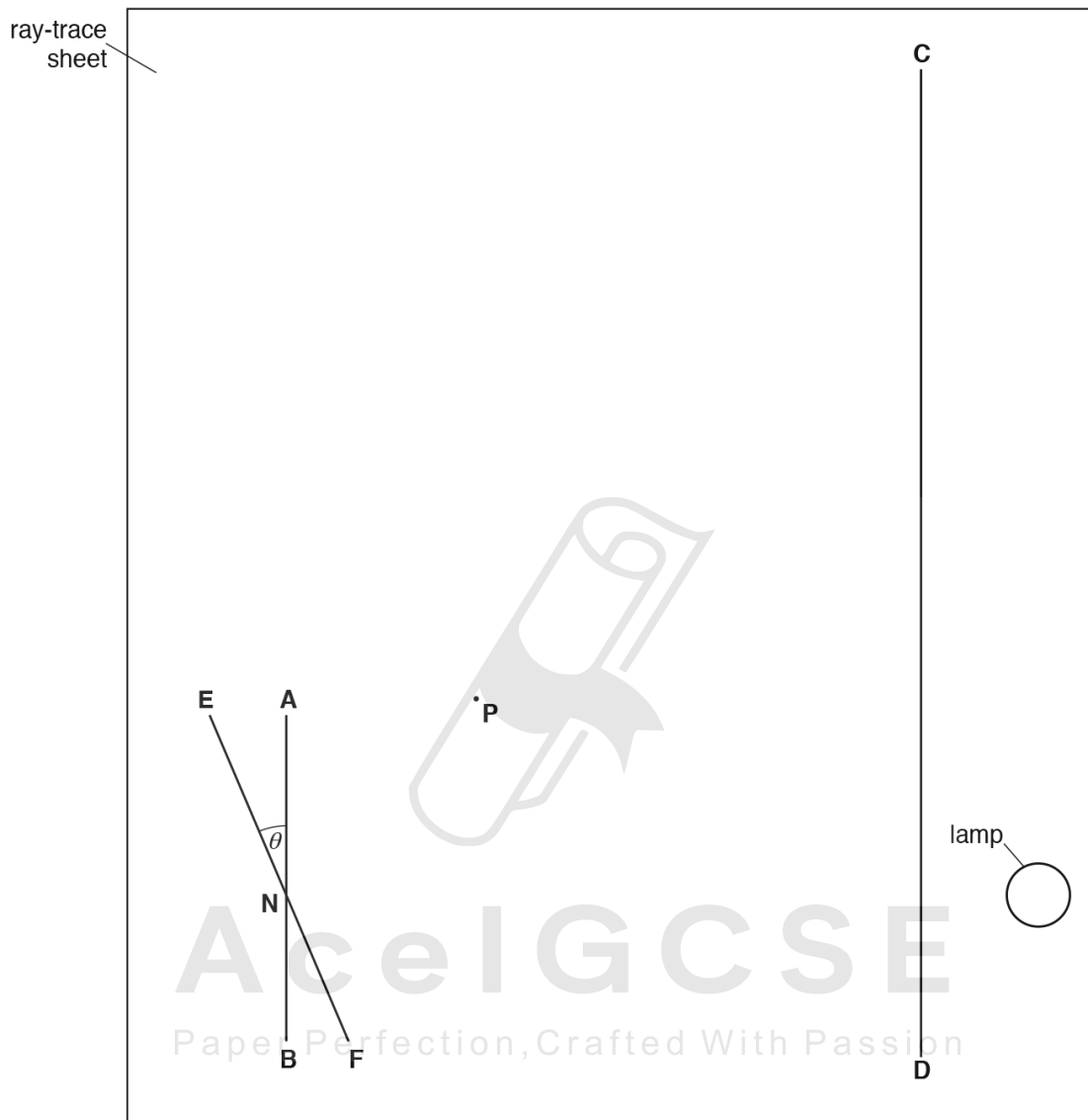

Fig. 1.1

- (a) The student carries out an initial experiment.
 He draws lines **AB** and **CD** as shown in Fig. 1.1.
 He then draws a line **EF** through a point **N** as shown in Fig. 1.1 and at an angle θ to line **AB**.

- (i) Measure the angle θ .

$\theta = \dots\dots\dots$ [1]

- (ii) Draw a normal to line **AB** at point **N** and extend the normal to line **CD**. Label the point at which the normal crosses line **CD** with the letter **L**. [1]

3.2. LIGHT

- (b) The student places a plane mirror on line **EF** and a screen with a 2 mm slit on line **CD**. He arranges the screen so that a ray of light shines along line **LN**. The ray reflected from the mirror passes through point **P**.

State and explain whether point **P**, shown on Fig. 1.1, is at a suitable distance from point **N** for this investigation.

statement

explanation

[1]

- (c) • Draw a line joining point **N** and point **P**. Extend this line until it meets line **CD**.
- Label the point at which this line meets line **CD** with the letter **G**.
- Measure the length *a* of line **LG**.

a = cm [2]

- (d) The student repeats the procedure for values of $\theta = 25^\circ, 20^\circ, 15^\circ, 10^\circ$ and 5° . His values for *a* are shown in Table 1.1.

Table 1.1

$\theta/^\circ$	<i>a</i> /cm
25	12.2
20	8.3
15	5.7
10	3.6
5	1.8

Use the values from Table 1.1 to plot a graph of a/cm (y -axis) against $\theta/^\circ$ (x -axis).

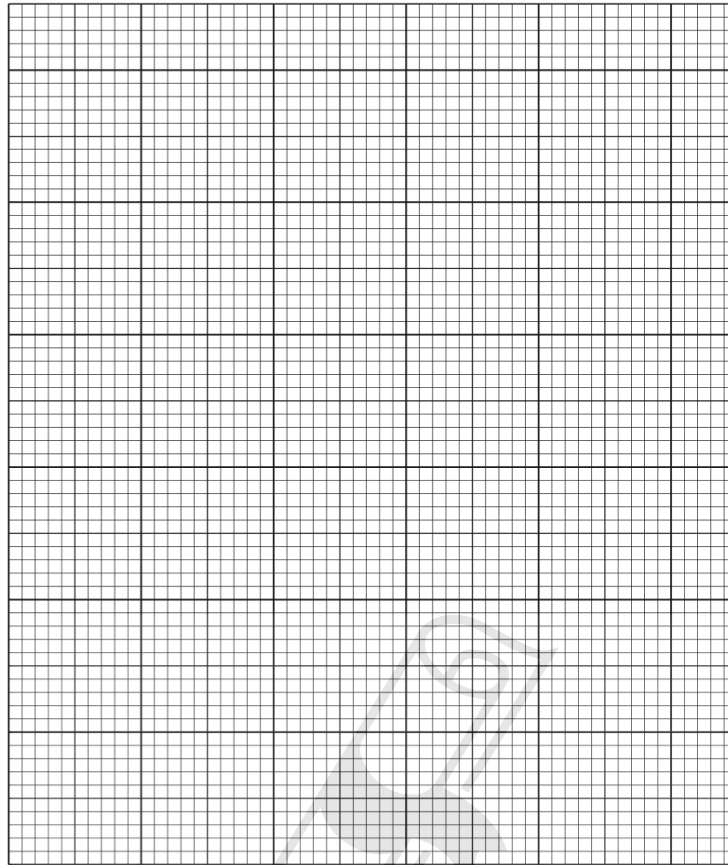

[4]

- (e) Suggest a possible source of inaccuracy in this experiment, even if it is carried out carefully.

.....
..... [1]

- (f) A student wishes to check if his values for a are reliable.

Suggest how he could improve the experiment, using the same apparatus, to check the reliability of his results.

.....
.....
..... [1]

[Total: 11]

3.2. LIGHT

04.0625_s19_qp_62 Q: 4

A student is investigating the relationship between the thickness of a converging (convex) lens and its focal length. Fig. 4.1 shows the cross-section of a converging lens.

The focal length f of a lens can be calculated if u (the distance between the object and the lens) and v (the distance between the lens and the image on a screen) are known.

The equation is: $f = \frac{uv}{(u + v)}$



Fig. 4.1

Plan an experiment to investigate the relationship between the thickness t and the focal length f of converging lenses. You may add to Fig. 4.1 as part of your answer.

The following apparatus is available to the student:

- illuminated object
- selection of lenses of different thicknesses and a lens holder
- screen
- metre rule
- 30 cm ruler
- two rectangular wooden blocks with the longest sides longer than the diameter of the lenses.

In your plan, you should:

- draw a diagram to show the arrangement of the apparatus, labelling u and v
- explain briefly how you would carry out the investigation, including the measurements you would take
- explain briefly how you would determine the thickness t of each lens (you may draw a diagram if it helps your explanation)
- draw a suitable table, with column headings, to show how you would display your readings (you do **not** need to use the equation to calculate focal length).

3.2. LIGHT

05.0625_w19_qp_62 Q: 3

A student determines the focal length f of a lens.

Fig. 3.1 shows the set-up.

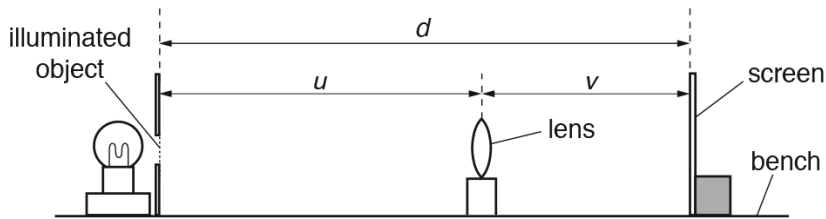

Fig. 3.1

- (a) • He places the screen at a fixed distance from the illuminated object.
- He places the lens between the object and the screen so that the lens is very close to the screen.
- He moves the lens slowly away from the screen until a clearly focused image is formed on the screen.
- He measures the distance u between the object and the centre of the lens and the distance v between the centre of the lens and the screen. The readings are shown in Table 3.1.

(i) On Fig. 3.1, measure the distance d between the illuminated object and the screen.

$d = \dots\dots\dots$ [1]

(ii) Fig. 3.1 is drawn 1/10th actual size. Calculate the actual distance D between the illuminated object and the screen.

$D = \dots\dots\dots$ [1]

(b) Calculate, and record in Table 3.1, the focal length f of the lens using the equation $f = \frac{uv}{D}$. [1]

- (c) • The student keeps the screen at the same fixed distance D from the illuminated object.
- He moves the lens slowly away from the screen. The image goes out of focus.
- He continues to move the lens slowly away from the screen until another clearly focused image is formed on the screen.
- He records the new readings of u and v in Table 3.1.

(i) Calculate, and record in Table 3.1 the new value for the focal length f of the lens using the equation $f = \frac{uv}{D}$. [1]

Table 3.1

u/cm	v/cm	f/cm
59.8	20.4	
19.8	60.0	

- (ii) Calculate the average value f_A of the focal length of the lens. Give your answer to a suitable number of significant figures for this experiment.

$$f_A = \dots\dots\dots \text{ cm [2]}$$

- (d) State **one** precaution that you would take to obtain accurate readings in this experiment.

.....
 [1]

- (e) Another student wants to obtain more measurements for u and for v to check the value for the focal length f of the lens. The student moves the screen a distance of 40.0cm to the right.

- (i) Calculate the new value for the distance D between the illuminated object and the screen.

$$D = \dots\dots\dots \text{ cm [1]}$$

- (ii) The student moves the lens to a new position which is a distance from the object $u = 22.2\text{cm}$. He observes the image on the screen and says it is clearly focussed at a distance $v = 97.9\text{cm}$.

Calculate the new value of the focal length f of the lens using $f = \frac{uv}{D}$.

Paper Perfection, Crafted With Passion

$$f = \dots\dots\dots \text{ cm [1]}$$

- (iii) State and explain briefly whether the values for f_A and f in (e)(ii) are the same within the limits of experimental accuracy.

.....

 [1]

[Total: 10]

3.2. LIGHT

06. 0625_w19_qp_63 Q: 2

Some students determine the focal length of a converging lens by two different methods.

They use the apparatus shown in Fig. 2.1.

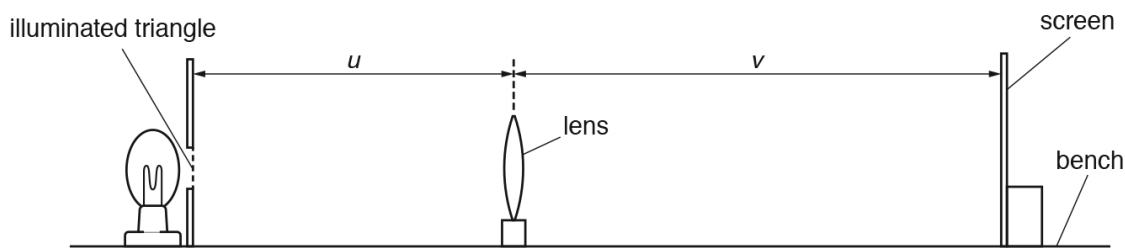

Fig. 2.1

- (a) A student sets the distance U between the illuminated triangle and the lens. She moves the screen until a sharp image of the triangle is seen on the screen.

Method 1

- (i) On Fig. 2.1, measure the distance u between the illuminated triangle and the lens.

$u =$

On Fig. 2.1, measure the distance v between the lens and the screen.

$v =$

[1]

- (ii) Fig. 2.1 is drawn to 1/5th scale.

Calculate the actual distance U between the illuminated triangle and the lens in the experiment.

$U =$

Calculate the actual distance V between the lens and the screen in the experiment.

$V =$

[1]

- (iii) Calculate a value f_1 for the focal length of the lens, using the equation $f_1 = \frac{UV}{(U + V)}$.

$f_1 =$ [1]

- (iv) Briefly describe a technique to obtain an image on the screen that is as sharp as possible in this experiment.

.....

 [1]

Method 2

- (b) (i) On Fig. 2.2, measure h_O , the height of the illuminated triangle.

$h_O =$

On Fig. 2.3, measure h_I , the height of the image on the screen.

$h_I =$ [1]

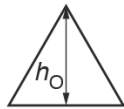

Fig. 2.2

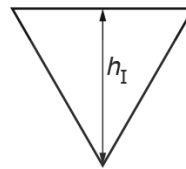

Fig. 2.3

- (ii) Calculate a value for the magnification M , using the equation $M = \frac{h_I}{h_O}$.

$M =$ [1]

- (iii) Calculate a second value f_2 for the focal length of the lens, using the equation $f_2 = \frac{V}{(M + 1)}$ and the value of V from (a)(ii).

$f_2 =$ [1]

- (c) A student suggests that f_1 and f_2 should be equal. State whether the results support this suggestion. Justify your statement with reference to the results.

statement

justification

..... [2]

3.2. LIGHT

- (d) State **one** precaution that could be taken to ensure that the measurements in the experiment are taken as reliably as possible.

.....
..... [1]

- (e) Suggest which of **Method 1** or **Method 2** is likely to give the more accurate value for the focal length.
Explain the reason for your choice.

suggestion

explanation

.....
..... [1]

[Total: 11]



Ace | GCSE
Paper Perfection, Crafted With Passion

07. 0625_s18_qp_61 Q: 3

A student is determining the focal length f of a lens.

Fig. 3.1 shows the apparatus.

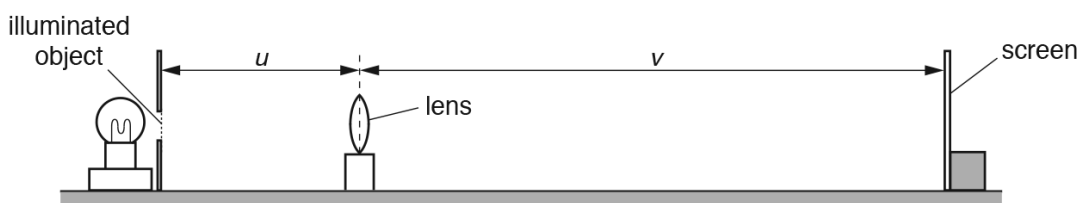

Fig. 3.1

(a) The student places the screen a distance $D = 70.0$ cm from the illuminated object.

He places the lens close to the screen and moves the lens slowly away from the screen until a clearly focused image is formed on the screen.

He measures the distance u between the centre of the lens and the illuminated object.

He measures the distance v between the centre of the lens and the screen.

He repeats the procedure using values for D of 75.0 cm, 80.0 cm, 85.0 cm and 90.0 cm.

The readings are shown in Table 3.1.

Calculate, and record in Table 3.1, uv for each value of D .

Table 3.1

D/cm	u/cm	v/cm	uv/cm^2
70.0	22.0	48.4	
75.0	20.7	54.5	
80.0	20.0	60.0	
85.0	19.5	65.8	
90.0	19.0	71.2	

[1]

3.2. LIGHT

- (b) Plot a graph of uv/cm^2 (y -axis) against D/cm (x -axis). You do **not** need to start your axes at the origin (0,0).

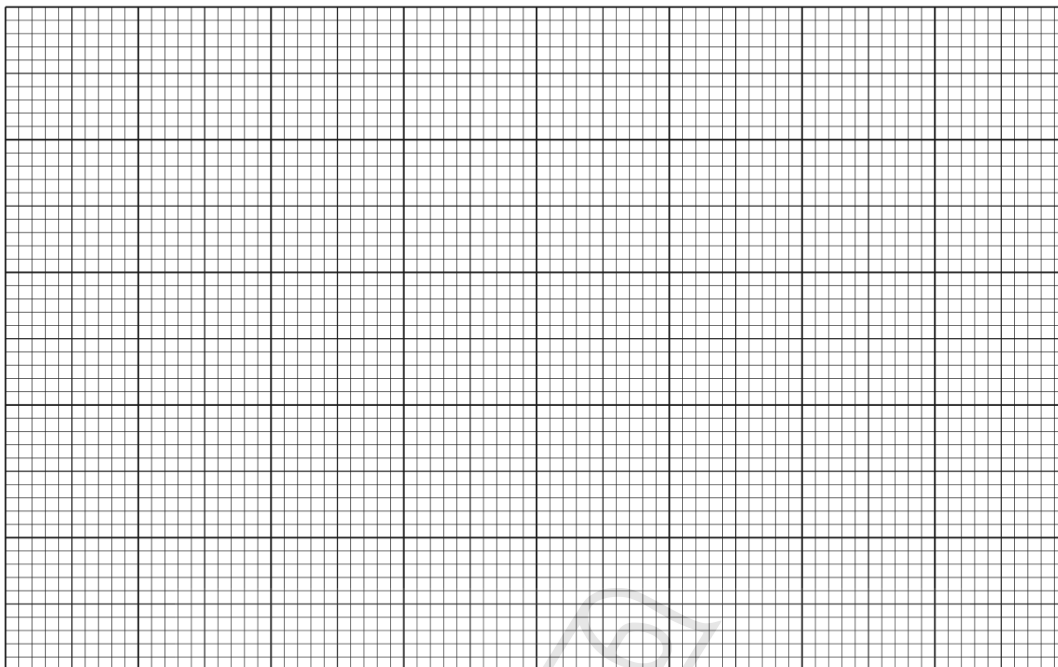

[4]

- (c) Determine the gradient G of the line. Show clearly on the graph how you obtained the necessary information.

$G = \dots\dots\dots$ [2]

- (d) The focal length f of the lens is numerically equal to the gradient G of the graph. Write down a value for the focal length f of the lens. Give your answer to a suitable number of significant figures for this experiment.

$f = \dots\dots\dots$ [2]

- (e) Suggest **two** difficulties in this experiment when trying to obtain accurate readings.

1.

.....

2.

.....

[2]

[Total: 11]

08. 0625_s18_qp_62 Q: 3

A student is determining the focal length of a lens.

Fig. 3.1 shows the apparatus used.

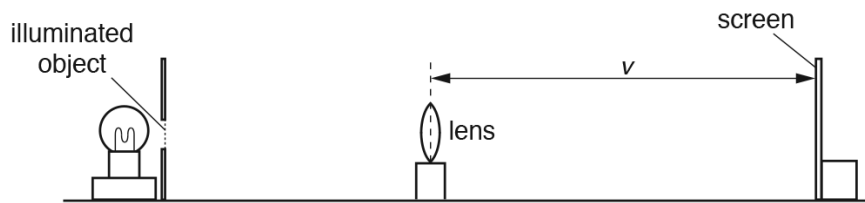

Fig. 3.1

- (a) The student adjusts the position of the screen until a clearly focused image is formed on the screen.

- (i) On Fig. 3.1, measure the distance v between the centre of the lens and the screen.

$v = \dots\dots\dots$ [1]

- (ii) Fig. 3.1 is drawn $1/5^{\text{th}}$ actual size.

Calculate V , the actual distance from the lens to the screen

$V = \dots\dots\dots$ [1]

- (iii) With a clearly focused image formed on the screen, the actual distance from the centre of the lens to the illuminated object, U is 20.0 cm.

Calculate the focal length f_1 of the lens using the equation $f_1 = \frac{UV}{(U + V)}$.

$f_1 = \dots\dots\dots$ [2]

- (b) The student repeats the procedure in (a), using a different distance U . She obtains another value for the focal length f_2 .

$f_2 = \dots\dots\dots 12.2 \text{ cm} \dots\dots\dots$

Calculate the average value f_A of the focal length of the lens, using f_2 and your value for f_1 in (a)(iii). Give your answer to a suitable number of significant figures for this experiment.

$f_A = \dots\dots\dots$ [2]

3.2. LIGHT

- (c) The student states that taking more measurements improves the reliability of the value obtained for f_A .

Suggest additional values for U that you would use.

.....
.....
..... [2]

- (d) State **two** precautions that you would take in this experiment to obtain accurate readings.

1.
.....
2.
..... [2]

[Total: 10]



Ace | GCSE
Paper Perfection, Crafted With Passion

09. 0625_s18_qp_63 Q: 3

A student is investigating the image produced by a converging lens.

She is using the apparatus shown in Fig. 3.1.

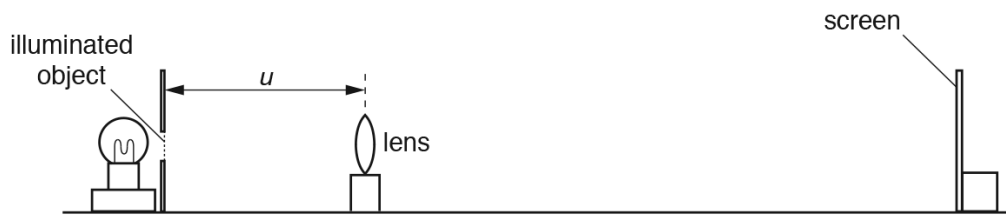

Fig. 3.1

- (a) The illuminated object consists of a triangular-shaped hole in a piece of card. Fig. 3.2 shows, full size, the illuminated object. Measure and record the height h_o of the triangular-shaped hole.

$h_o = \dots\dots\dots$ cm [1]

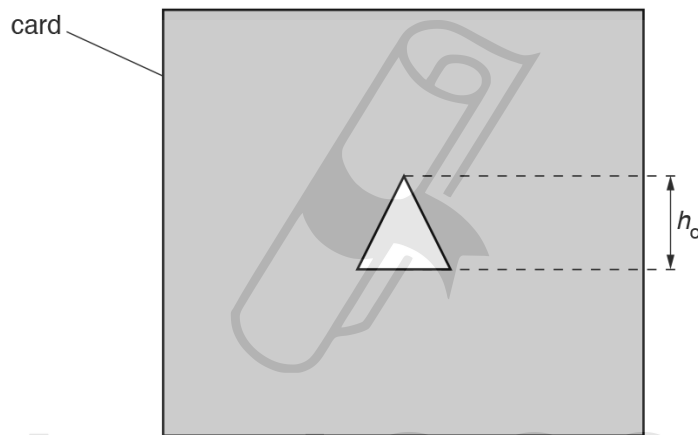

Fig. 3.2

AceIGCSE
Paper Perfection, Crafted With Passion

3.2. LIGHT

- (b) The distance u between the triangular object and the centre of the lens is set to 20.0 cm. The screen is moved until a focused image of the illuminated object is seen, as shown in Fig. 3.3.

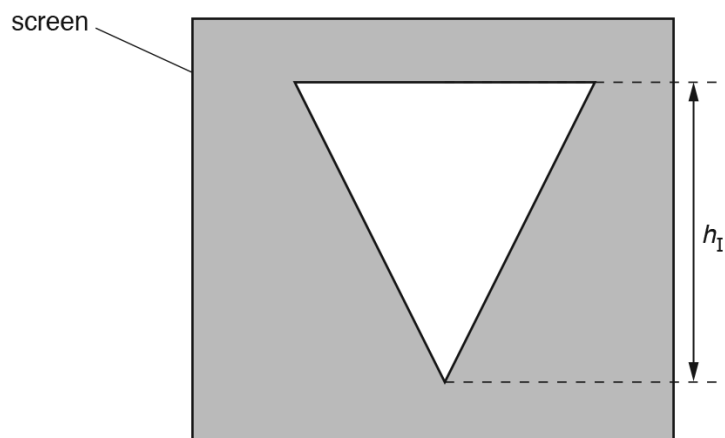

Fig. 3.3

The student repeats the procedure for u values of 30.0 cm, 40.0 cm, 50.0 cm and 60.0 cm. Her results are shown in Table 3.1.

- (i) Measure and record in the first row of Table 3.1, the height h_I of the image. [1]
- (ii) Calculate, and record in the table, a value N using your measurements for h_o and h_I and the equation $N = \frac{h_o}{h_I}$.

Table 3.1

u/cm	h_I/cm	N
20.0		
30.0	1.5	0.93
40.0	0.9	1.6
50.0	0.6	2.3
60.0	0.5	2.8

[1]

- (c) Plot a graph of u/cm (y -axis) against N (x -axis). You do not have to start your graph at the origin (0, 0).

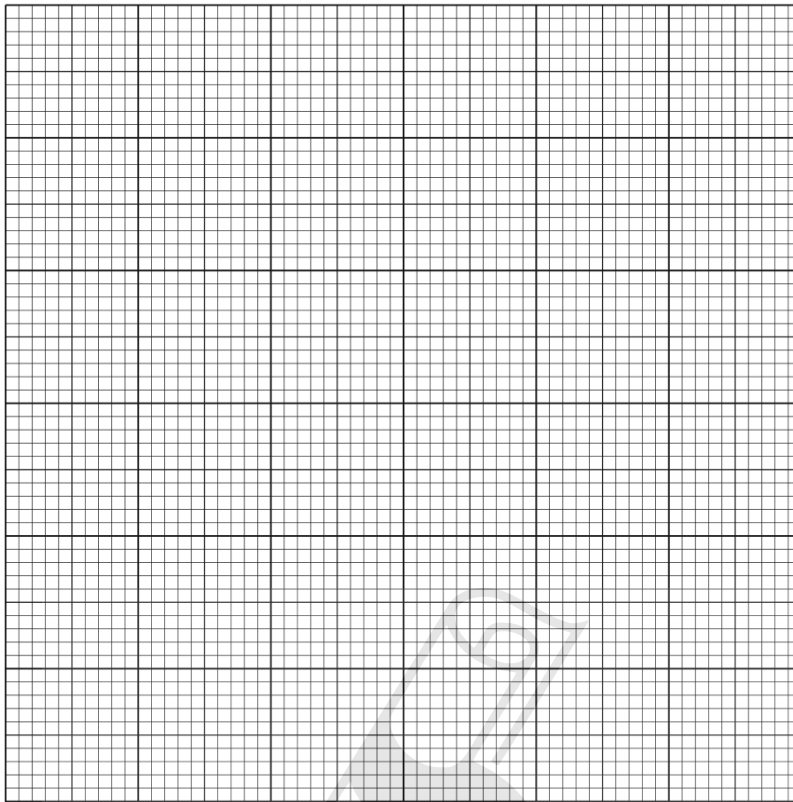

[4]

- (d) Determine the gradient G of the graph.
Show clearly on the graph how you obtained the necessary information.

AcelGCSE
Paper Perfection, Crafted With Passion

$G = \dots\dots\dots$ [2]

- (e) Describe **one** difficulty that might be experienced when measuring the height of the image h_1 . Suggest an improvement to the apparatus to overcome this difficulty.

difficulty

.....

improvement

.....

[2]

[Total: 11]

3.2. LIGHT

10. 0625_w18_qp_61 Q: 3

A student is determining the refractive index n of the material of a transparent block.

Fig. 3.1 shows the outline **ABCD** of the transparent block.

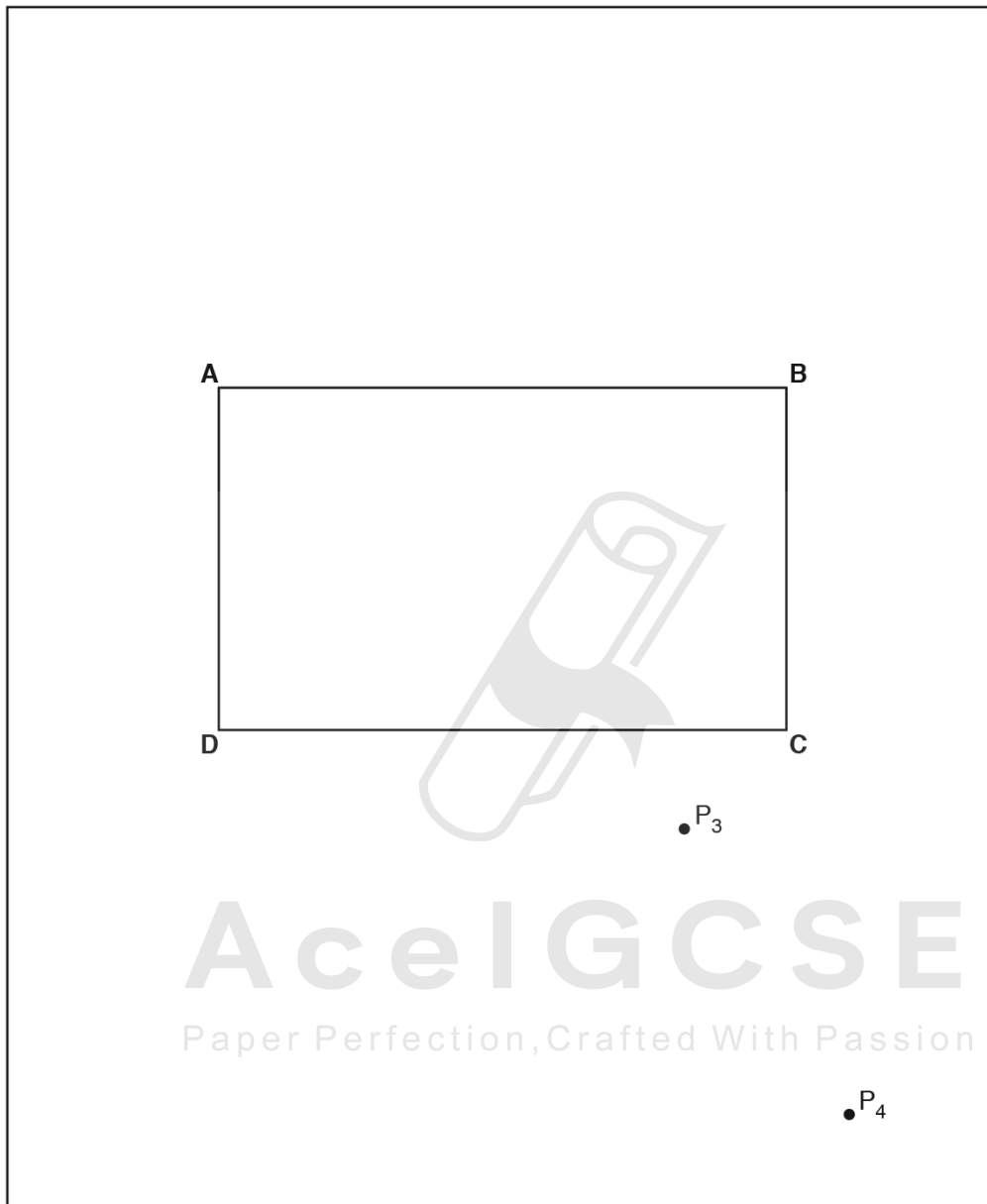

Fig. 3.1

- (a) (i) On Fig. 3.1:
- draw a normal **NL** at the centre of side **AB**
 - continue the normal so that it passes through side **CD** of the block
 - label the point **F** where **NL** crosses **AB**
 - label the point **G** where **NL** crosses **CD**. [1]
- (ii) Draw a line **EF** at an angle $i = 30^\circ$ to the left of the normal and above side **AB**. [1]
- (iii) Mark the positions of two pins P_1 and P_2 on line **EF** placed at a suitable distance apart for this type of ray-tracing experiment. [1]

- (b) The student observes the images of P_1 and P_2 through side **CD** of the block so that the images of P_1 and P_2 appear one behind the other.

He places two pins P_3 and P_4 between his eye and the block so that P_3 , P_4 and the images of P_1 and P_2 seen through the block, appear one behind the other.

The positions of P_3 and P_4 are marked on Fig. 3.1.

- (i) • Draw a line joining the positions of P_3 and P_4 . Continue the line until it meets the normal **NL**.
- Label the point **H** where the line meets side **CD**. Draw the line **FH**. [1]
- (ii) Measure and record the length a of the line **GH**.
- $a = \dots\dots\dots$ [1]
- (iii) Measure and record the length b of the line **FH**.
- $b = \dots\dots\dots$ [1]
- (iv) Calculate the refractive index n using the equation $n = \frac{0.5b}{a}$.
- $n = \dots\dots\dots$ [1]

AcelGCSE
Paper Perfection, Crafted With Passion

3.2. LIGHT

(c) The student repeats the procedure using the angle of incidence $i = 45^\circ$.

$a = \dots\dots\dots 3.2 \dots\dots\dots$ cm

$b = \dots\dots\dots 6.9 \dots\dots\dots$ cm

Calculate the refractive index n , using the equation $n = \frac{0.71b}{a}$.

$n = \dots\dots\dots$ [1]

(d) The student expected the two values of refractive index n obtained in this experiment to be equal.

State **two** difficulties with this type of experiment that could explain any difference in the two values of n .

- 1.
.....
 - 2.
.....
- [2]

(e) A student suggests precautions to take in this experiment to obtain reliable results. Tick **one** box to indicate the most sensible suggestion.

- Carry out the experiment in a darkened room.
- Use pins that are taller than the height of the block.
- View the bases of the pins.
- View the pins with one eye closed.

[1]

[Total: 11]

11. 0625_w18_qp_62 Q: 3

A student is determining the refractive index n of the material of a transparent block.

Fig. 3.1 shows the outline **ABCD** of the block.

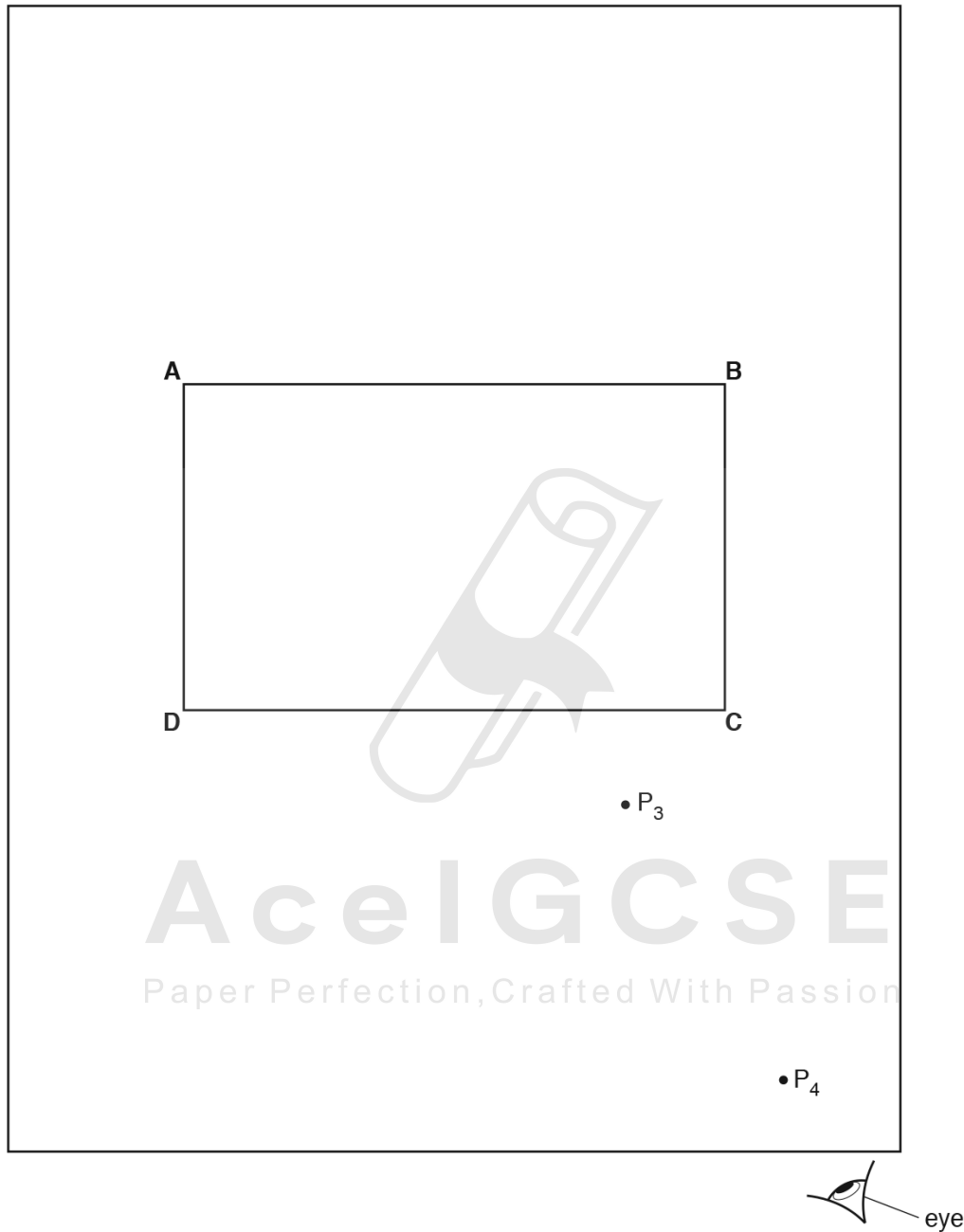

Fig. 3.1

- (a) (i)
- On Fig. 3.1, draw a normal **NL** at the centre of side **AB**.
 - Continue the normal so that it passes through side **CD** of the block.

[1]

3.2. LIGHT

- (ii) • Label the point **F** where **NL** crosses **AB**.
- Label the point **G** where **NL** crosses **CD**.
- Draw a line **EF** at an angle $i = 30^\circ$ to the left of the normal and above side **AB**. [1]

(iii) Mark the positions of two pins P_1 and P_2 on line **EF** placed at a suitable distance apart for this type of ray-tracing experiment. [1]

(b) The student observes the images of P_1 and P_2 through side **CD** of the block.

He places two pins P_3 and P_4 between his eye and the block so that P_3 , P_4 and the images of P_1 and P_2 seen through the block, all appear exactly one behind the other.

The positions of P_3 and P_4 are marked on Fig. 3.1.

- Draw a line passing through P_3 and P_4 . Continue the line until it meets the normal **NL**.
- Label the point **J** where the line meets the normal.
- Label the point **H** where the line meets side **CD**. Draw the line **FH**. [1]

(c) (i) Measure and record the length a of the line **FH**.

$a = \dots\dots\dots$ [1]

(ii) Measure and record the length b of the line **HJ**.

$b = \dots\dots\dots$ [1]

(iii) Calculate the refractive index n using the equation $n = \frac{a}{b}$.

$n = \dots\dots\dots$ [2]

(d) A student states that repeating the experiment improves the reliability of the value obtained for n .

Suggest additional values for the angle of incidence i that you would use when repeating the experiment to improve the reliability.

.....

 [2]

(e) State **one** precaution that you would take in this experiment to obtain accurate results.

.....
 [1]

[Total: 11]

12. 0625_w18_qp_63 Q: 3

A student is investigating the reflection of light by a plane mirror.

Her ray-trace sheet is shown in Fig. 3.1.

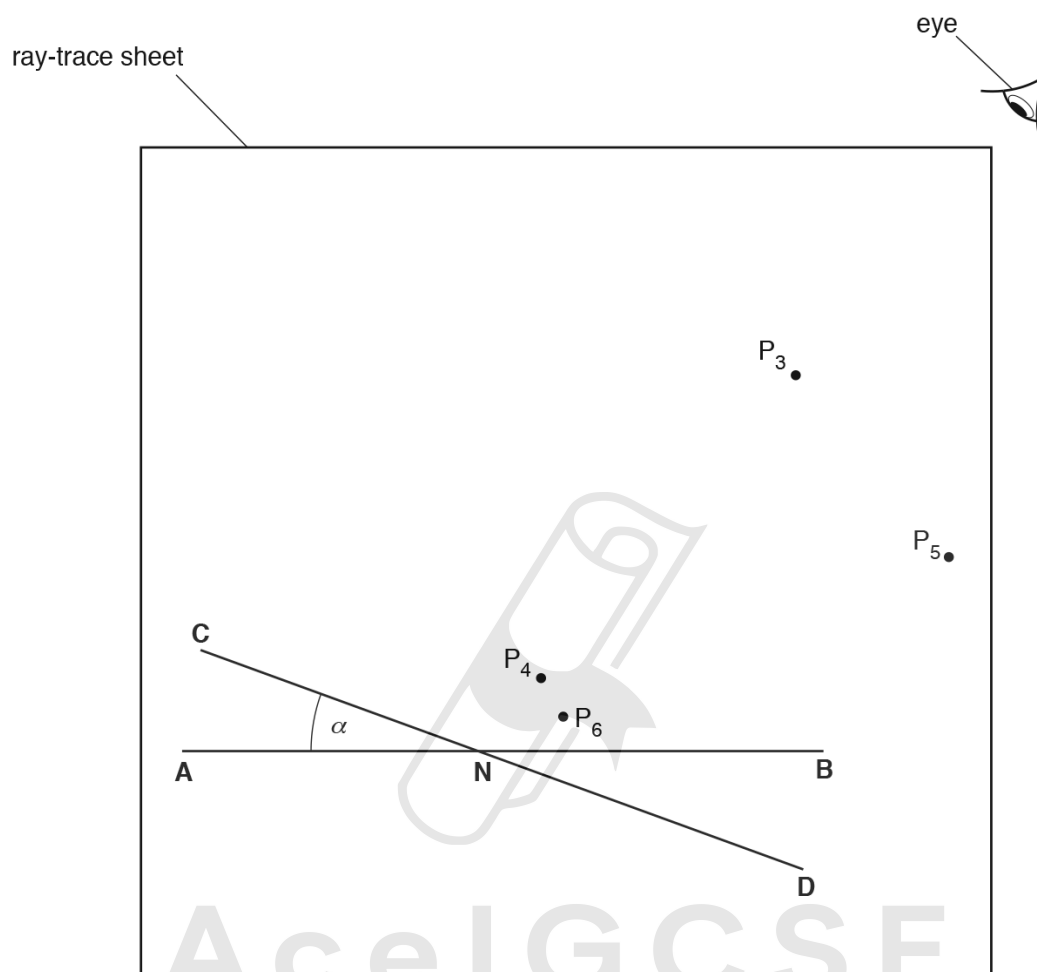

Fig. 3.1

- (a) (i) Measure and record in Table 3.1 the angle α between **AN** and **CN**, as shown in Fig. 3.1. [1]
- (ii) Draw a normal to **AB** at point **N**, towards the top of the page. Label the top point of this normal **L**. [1]
- (iii) Two pins P_1 and P_2 are placed on line **LN**, a suitable distance apart for ray tracing. On Fig. 3.1, label suitable positions for P_1 and P_2 . [1]

3.2. LIGHT

- (b) The student places the reflecting surface of a plane mirror on line **CD** and views the images of P_1 and P_2 from the direction indicated by the eye in Fig. 3.1.

She places two pins P_3 and P_4 so that the images of P_1 and P_2 , and the pins P_3 and P_4 , all appear exactly one behind the other.

- (i) Draw a line passing through P_3 and P_4 and reaching point **N**. [1]

- (ii) Measure the angle θ between this line and the normal **LN**. Record this value in Table 3.1. [1]

Table 3.1

	$\alpha/^\circ$	$\theta/^\circ$
mirror on CD		
mirror on EF	35	

- (c) The student moves the mirror to a line **EF** at an angle $\alpha = 35^\circ$ to **AN**. Line **EF** is not shown in Fig. 3.1. The student repeats the process with the mirror on **EF** and places pins P_5 and P_6 in line with the new images.

- (i) Draw a line passing through P_5 and P_6 and reaching point **N**. [1]

- (ii) Measure the angle θ between this new line and the normal **LN**. Record this value in Table 3.1. [1]

- (d) A student suggests that when the mirror is moved, the **change in** θ should be equal to twice the **change in** α .

State whether your readings support this idea. Justify your answer with reference to the readings.

statement

justification

.....

..... [2]

- (e) Suggest two precautions that you would take to ensure accurate results from this type of experiment.

1

.....

2

.....

[2]

[Total: 11]

13. 0625_m17_qp_62 Q: 3

Some students are investigating the magnification produced by a converging lens.

They are using the apparatus shown in Fig. 3.1.

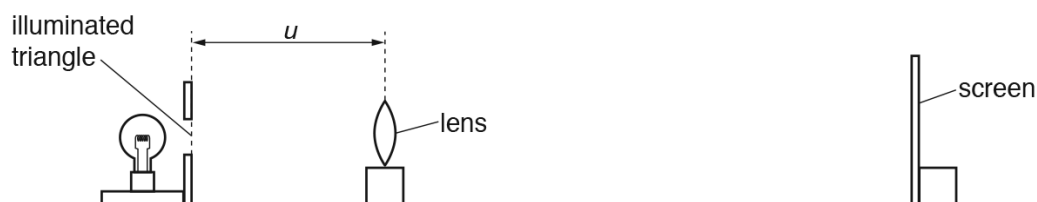

Fig. 3.1

- (a) A student sets the distance u between the illuminated triangle and the lens to 20.0 cm. She moves the screen until a sharp image of the triangle is seen on the screen.

The student measures the height of the illuminated triangle h_0 .

$$h_0 = \dots\dots\dots 1.5 \text{ cm} \dots\dots\dots$$

Measure and record, in Table 3.1, the height of the image of the triangle h_1 on the screen, as shown in Fig. 3.2. [1]

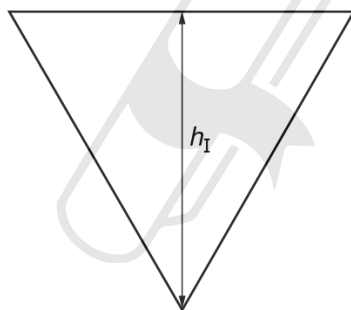

Fig. 3.2

AcelGCSE
Paper Perfection, Crafted With Passion

Table 3.1

u/cm	h_1/cm	M
20.0		
25.0	2.25	
35.0	1.10	
45.0	0.75	
55.0	0.55	

3.2. LIGHT

- (b) The student measures the height h_I of the image for u values of 25.0cm, 35.0cm, 45.0cm and 55.0cm. Her results are shown in Table 3.1.

For each value of u , calculate and record in Table 3.1 a value for the magnification M .

Use the equation $M = \frac{h_I}{h_O}$ and the value of h_O from (a). [1]

- (c) Plot a graph of M (y -axis) against u/cm (x -axis).

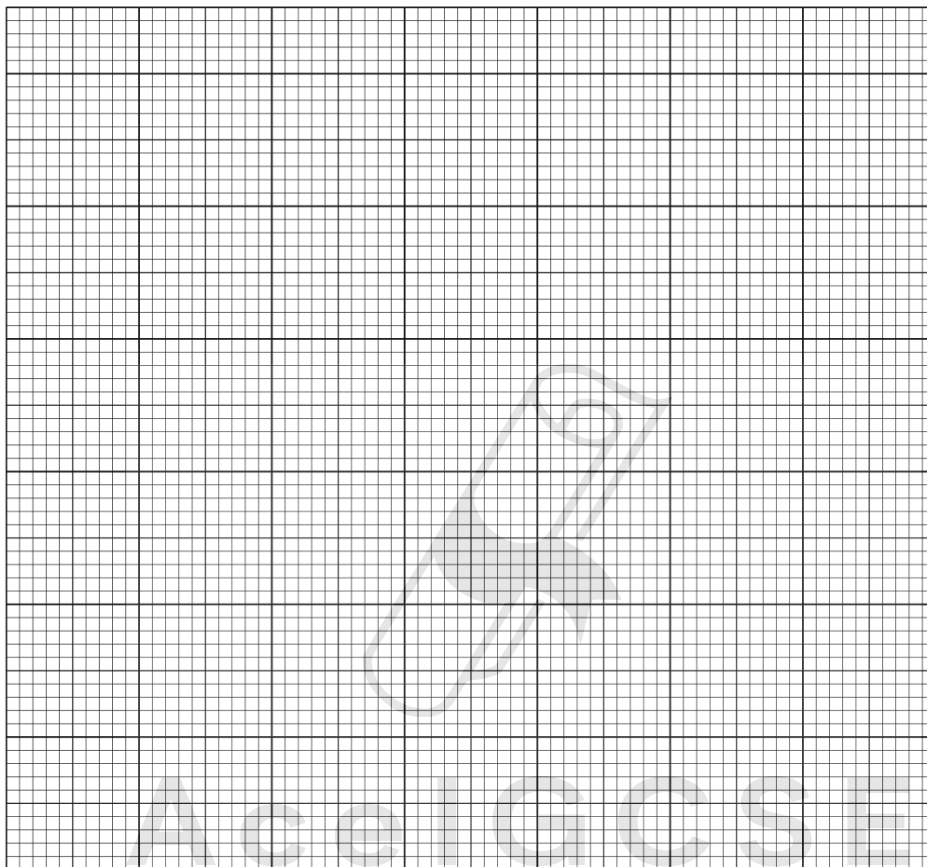

Paper Perfection, Crafted With Passion

[4]

- (d) From your graph, determine the value of u when $M = 1.0$. Show clearly on your graph how you obtained the information.

$u = \dots\dots\dots$ [2]

- (e) Describe **one** difficulty that might be experienced when measuring the height of the image in this experiment. Suggest **one** improvement to the apparatus to overcome this.

difficulty

.....

improvement

.....

[2]

- (f) When setting up the apparatus, the student makes sure that the card with the illuminated triangle, the lens and the screen are all perpendicular to the bench.

Explain why this is an important precaution in this experiment.

.....

.....

.....[1]

[Total: 11]



Ace | GCSE
Paper Perfection, Crafted With Passion

3.2. LIGHT

14. 0625_s17_qp_61 Q: 2

The class is investigating the refraction of light passing through a transparent block. A student is using optics pins to trace the paths of rays of light.

Fig. 2.1 shows the student's ray-trace sheet.

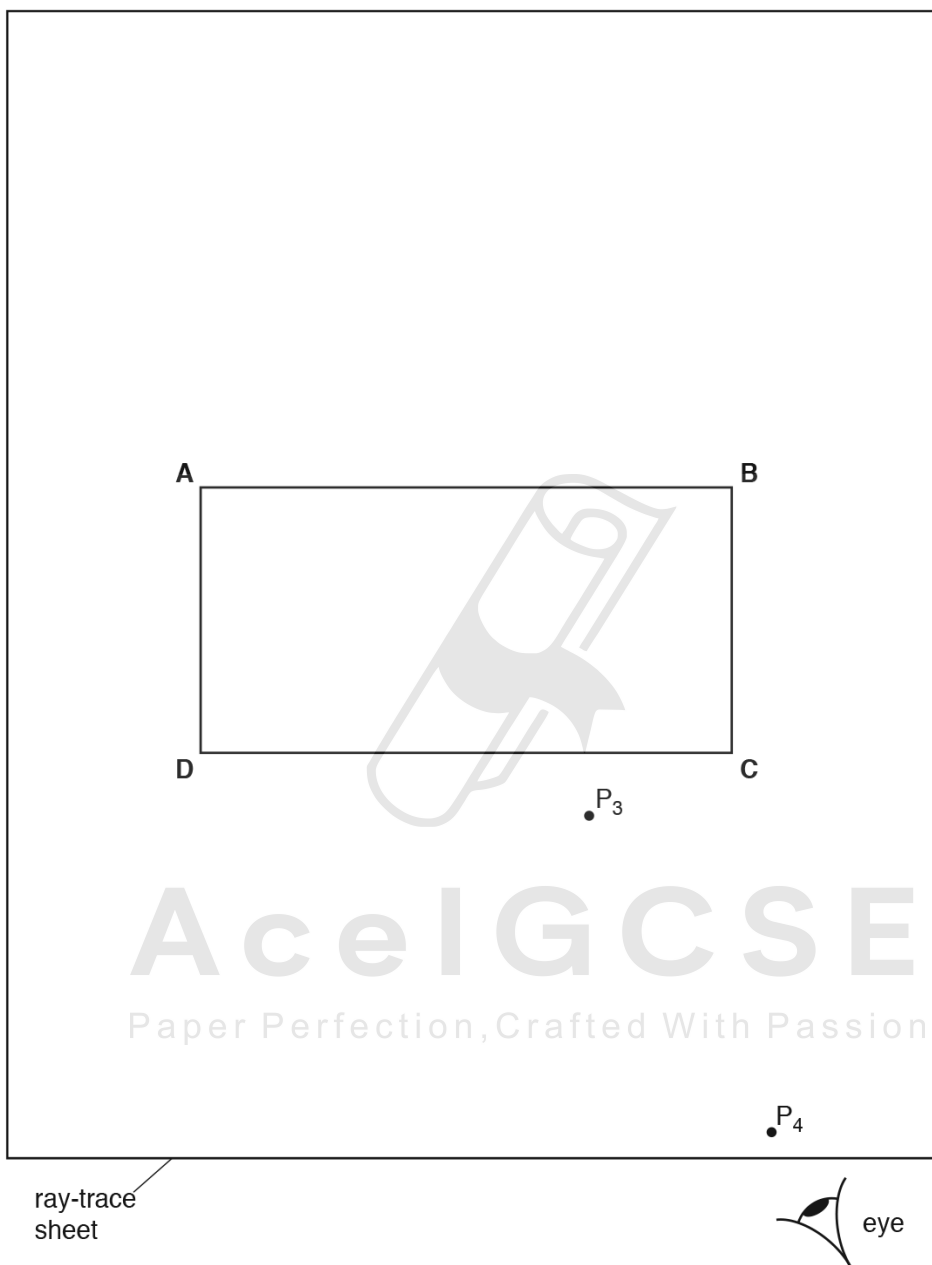

Fig. 2.1

- (a) • On Fig. 2.1, draw a normal at the centre of side **AB**. Label this line **NL**. Label the point **E** where the normal crosses **AB**. Label the point **M** where the normal crosses **CD**.
- Draw a line above **AB** to the left of the normal and at an angle of incidence $i = 30^\circ$ to the normal. Label this line **FE**.
 - Label the positions of two pins P_1 and P_2 placed a suitable distance apart on **FE** for accurate ray tracing. [2]

- (b) The student observes the images of P_1 and P_2 through side **CD** of the block so that the images of P_1 and P_2 appear one behind the other. He places two pins P_3 and P_4 between his eye and the block so that P_3 and P_4 , and the images of P_1 and P_2 seen through the block, appear one behind the other. The positions of P_3 and P_4 are marked on Fig. 2.1.

Draw a line joining the positions of P_3 and P_4 . Continue the line until it meets the normal. Label this point **K**. [1]

- (c) • Measure and record the angle α between the line joining the positions of P_3 and P_4 and the line **KM**.

$\alpha =$

- Measure and record the length x between points **M** and **K**.

$x =$ [2]

- (d) The student repeats the procedure with the angle of incidence $i = 50^\circ$. His readings for α and x are shown.

$\alpha =$ 52°

$x =$ 19mm

A student suggests that the angle α should always be equal to the angle of incidence i .

State whether the results support this suggestion. Justify your answer by reference to the values of α for $i = 30^\circ$ and $i = 50^\circ$.

statement
Paper Perfection Crafted With Passion

justification [2]

- (e) Suggest **one** precaution that you would take with this experiment to obtain reliable results.
-
-
- [1]

[Total: 8]

3.2. LIGHT

15. 0625_s17_qp_62 Q: 2

The class is investigating the refraction of light passing through a transparent block. A student is using optics pins to trace the paths of rays of light.

Fig. 2.1 shows the student's ray-trace sheet.

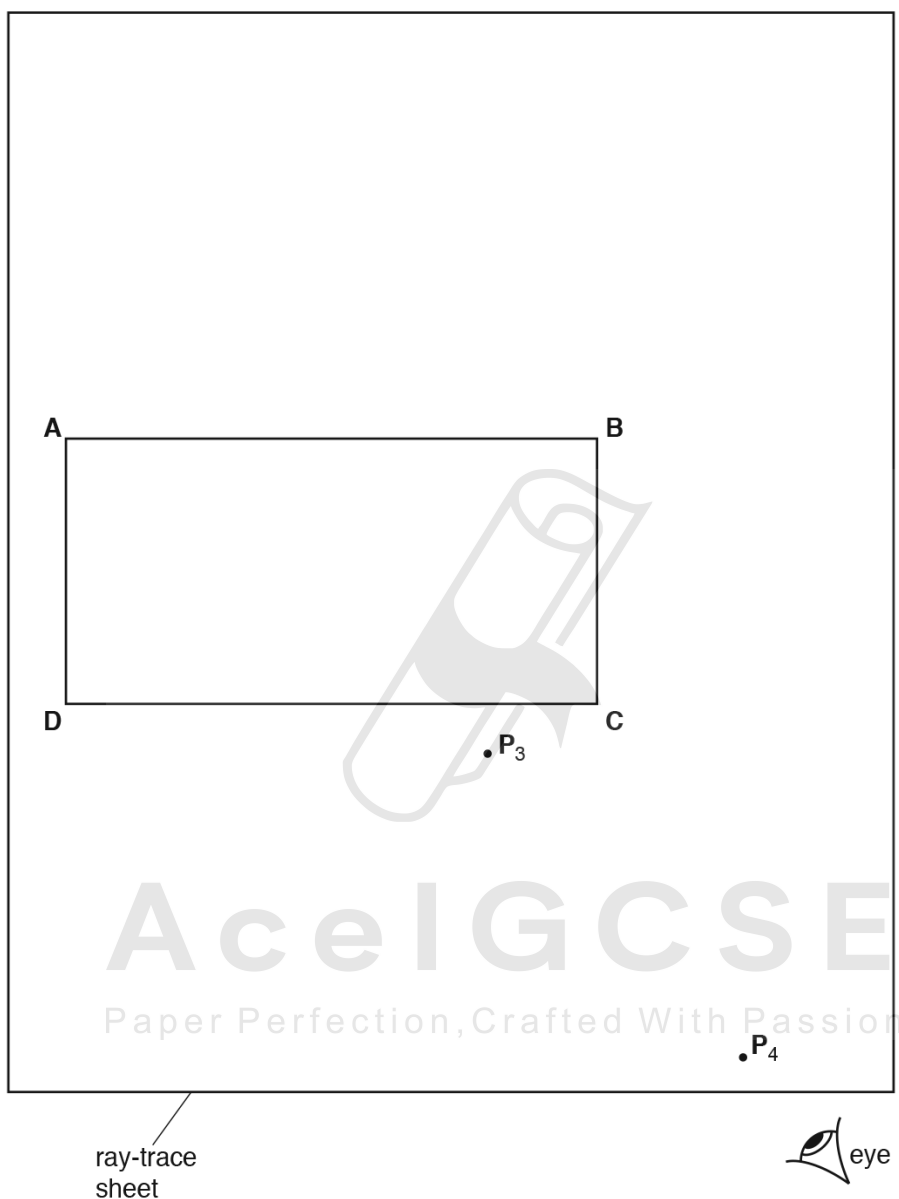

Fig. 2.1

- (a) • On Fig. 2.1, draw and label a normal **NL** at the centre of side **AB**. Label the point **E** where the normal crosses **AB**. Label the point **M** where the normal crosses **CD**. [1]
- Draw a line **FE**, to the left of the normal and at an angle of incidence $i = 40^\circ$ to the normal.
- Label the positions of two pins P_1 and P_2 on **FE** placed a suitable distance apart for accurate ray tracing. [2]

- (b) The student observes the images of P_1 and P_2 through side **CD** of the block so that the images of P_1 and P_2 appear one behind the other.

He places two pins P_3 and P_4 between his eye and the block so that P_3 and P_4 , and the images of P_1 and P_2 seen through the block, appear one behind the other.

The positions of P_3 and P_4 are marked on Fig. 2.1.

Draw a line joining the positions of P_3 and P_4 . Continue the line until it meets the normal **NL**. Label the point **K** where this line crosses **CD**. [1]

- (c) • Measure and record the angle α between the line joining the positions of P_3 and P_4 and the normal line.

$\alpha = \dots\dots\dots$

- Measure and record the length x between points **M** and **K**.

$x = \dots\dots\dots$

[2]

- (d) The student repeats the procedure but with the line **FE** to the right of the normal.

He measures the angle β between the line joining the new positions of P_3 and P_4 and the normal.

$\beta = \dots\dots\dots 41^\circ$

He measures the length y between **M** and the new position of **K**.

$y = \dots\dots\dots 21 \text{ mm}$

A student suggests that the results for α and x should be the same as the results for β and y .

State whether the results support this suggestion. Justify your answer by reference to the results.

statement **Ace IGCSE**
 justification **Paper Perfection, Crafted With Passion**

[2]

- (e) Suggest **one** precaution that you would take with this experiment to obtain reliable results.

.....

 [1]

[Total: 9]

3.2. LIGHT

16. 0625_s17_qp_62 Q: 3

The class is investigating images formed on a screen using a lens.

Fig. 3.1 shows the apparatus.

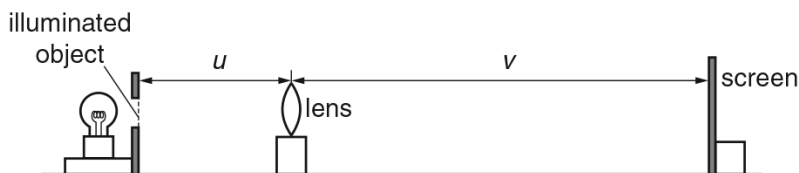

Fig. 3.1

- (a) The lens has a focal length of 15.0 cm.

Suggest a suitable distance D between the illuminated object and the screen in order to form a clearly focused image on the screen.

$D = \dots\dots\dots$ [1]

- (b) The student places the lens as shown in the diagram a distance u from the object. She then moves the screen until she obtains a clearly focused image on the screen.

It is difficult to decide on the exact position of the screen that gives the best image.

Explain how you would find the best position for the screen as reliably as possible.

.....
 [1]

- (c) Another student uses a different lens and obtains these readings:

$u = \dots\dots\dots 15.0 \text{ cm}$
 $v = \dots\dots\dots 29.7 \text{ cm}$

Calculate the focal length f of the lens using the equation $f = \frac{uv}{(u + v)}$.

Include the unit and give your answer to a suitable number of significant figures.

$f = \dots\dots\dots$ [2]

- (d) Suggest **one** difference that you would expect to see in this experiment between the appearance of the object and the image.

.....[1]

- (e) Which of the following procedures, **A–F**, are sensible for this experiment?
Circle one or more of the letters.

- A** Carry out the experiment in a darkened room.
 - B** Close one eye when taking readings.
 - C** Draw thin lines.
 - D** Fix the rule in position on the bench.
 - E** Make sure the pins are at least 5 cm apart.
 - F** Repeat the experiment using different values of u and determine an average value for f .
- [3]

[Total: 8]



AcelGCSE
Paper Perfection, Crafted With Passion

3.2. LIGHT

17. 0625_s17_qp_63 Q: 3

A student is investigating the refraction of light by a transparent block. She uses her results to determine a quantity known as the refractive index of the material of the block.

The student's ray-trace sheet is shown full size in Fig. 3.1.

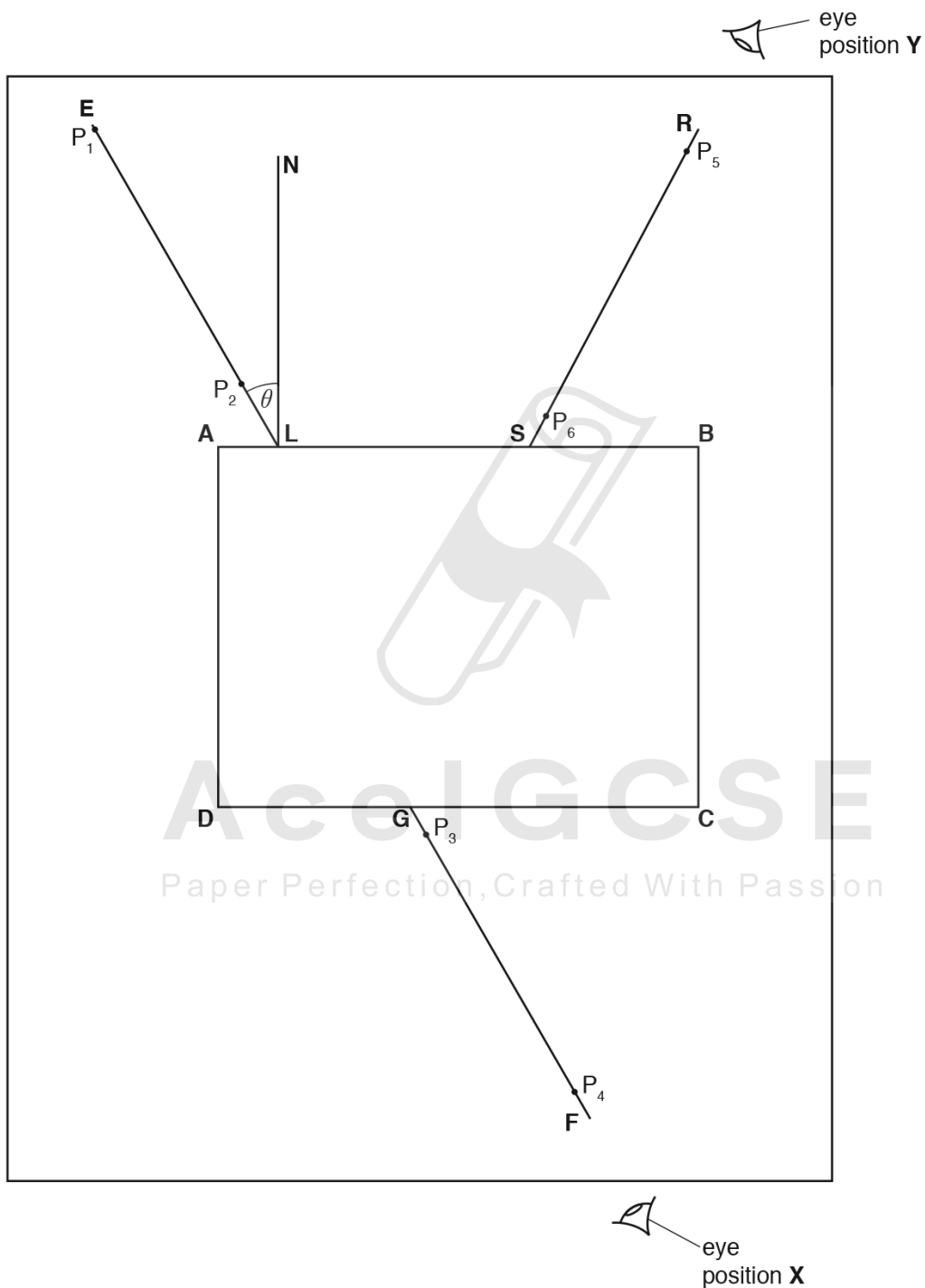

Fig. 3.1

- (a) The student places a transparent block **ABCD** at the centre of the ray-trace sheet, as indicated in Fig. 3.1. She draws round the block. She removes the block and then draws lines **NL** and **EL**.

Measure the angle θ between the lines **NL** and **EL**.

$$\theta = \dots\dots\dots[1]$$

- (b) The student places two pins P_1 and P_2 on line **EL**, a suitable distance apart for accurate ray-tracing.

Suggest a suitable distance between the two pins.

$$\text{distance} = \dots\dots\dots[1]$$

- (c) The student replaces the block. She views the images of P_1 and P_2 through the block from the direction indicated by the eye in position **X** in Fig. 3.1.

She places two pins P_3 and P_4 so that pins P_3 and P_4 , and the images of P_1 and P_2 , all appear exactly one behind the other.

She labels the positions of P_3 and P_4 and then removes the block and pins from the ray-trace sheet.

She draws a line **FG** through P_3 and P_4 , extending it as far as **CD**.

- (i) • Draw a normal to **CD** at point **G** and extend it to meet **AB**.
 • Label the point at which this normal meets **AB** with the letter **H**. [1]

- (ii) • Draw a line joining points **L** and **G**.
 • Extend line **EL** until it meets **GH**.
 • Label the point at which this line meets **GH** with the letter **K**.
 • Measure the length a of line **LG**.
 $a = \dots\dots\dots$ cm
 • Measure the length b of line **LK**.
 $b = \dots\dots\dots$ cm [1]

- (iii) Calculate a value n for the refractive index, using the equation $n = \frac{a}{b}$.

$$n = \dots\dots\dots[2]$$

3.2. LIGHT

- (d) The student places a mirror against side **CD**, with the reflecting surface facing towards the block.
She views the images of P_1 and P_2 from the direction indicated by the eye in position **Y** in Fig. 3.1.
She places two pins P_5 and P_6 so that pins P_5 and P_6 , and the images of P_1 and P_2 , all appear exactly one behind the other.

She labels the positions of P_5 and P_6 and then removes the mirror and the pins from the ray-trace.

The student draws a line **RS** through pins P_5 and P_6 .

- (i) • Extend line **RS** until it meets **GH**.
• Label the point at which this line meets **GH** with the letter **T**.
• Measure the angle α , where α is the smaller angle between lines **RT** and **GH**.

$\alpha =$ [2]

- (ii) A student suggests that angle α and angle θ , measured in part (a), should be equal.

State whether the results support this suggestion. Justify your answer with reference to the results.

statement

justification

[2]

- (e) Suggest why different students, all carrying out this experiment carefully, may not obtain identical results.

.....

..... [1]

Ace | GCSE

[Total: 11]

Paper Perfection, Crafted With Passion

18. 0625_w17_qp_61 Q: 2

A student is determining the focal length f of a lens.
Fig. 2.1 shows the apparatus used.

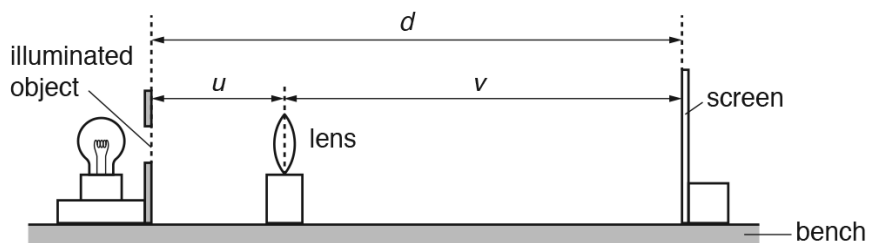

Fig. 2.1

(a) The student obtains a sharply-focused image on the screen.

(i) On Fig. 2.1, measure the distance v from the lens to the screen.

$v =$

(ii) On Fig. 2.1, measure the distance d from the illuminated object to the screen.

$d =$

[2]

(b) Fig. 2.1 is drawn $1/10^{\text{th}}$ actual size.

(i) Calculate V , the actual distance from the lens to the screen. Record the value of V in the first row of Table 2.1.

(ii) Calculate D , the actual distance from the illuminated object to the screen. Record the value of D in the first row of the table.

(iii) Calculate UV and record the result in the table.

[2]

(c) The student repeated the procedure with the lens at a distance $U = 30.0\text{cm}$ from the illuminated object. All the readings are recorded in the table.

Table 2.1

U/cm	V/cm	UV/cm^2	D/cm
20.0			
30.0	29.5	885	59.5

State **one** difference that you would expect to observe between the image formed on the screen when $U = 20.0\text{cm}$ and when $U = 30.0\text{cm}$.

.....

.....[1]

3.2. LIGHT

- (d) (i) Use the results in the first row of the table to calculate a value f_1 for the focal length of the lens. Use the equation $f_1 = \frac{UV}{D}$.

$f_1 =$

- (ii) Use the results in the second row of the table to calculate a value f_2 for the focal length of the lens. Use the equation $f_2 = \frac{UV}{D}$.

$f_2 =$

- (iii) Calculate the average value f_A for the focal length of the lens. Give your answer to a suitable number of significant figures for this experiment.

$f_A =$ [3]

- (e) Suggest **two** reasons why it may be difficult to obtain reliable results in this experiment.

1.
.....
2.
..... [2]

- (f) A student states that a more reliable value for the focal length is obtained if more values of U , V and D are collected, enabling a graph to be drawn of UV against D .

- (i) Suggest a suitable number of values for U .
.....
- (ii) Suggest a suitable range of values for U .
..... [2]

[Total: 12]

19. 0625_w17_qp_62 Q: 3

A student is determining the focal length f of a lens.

Fig. 3.1 shows the apparatus used.

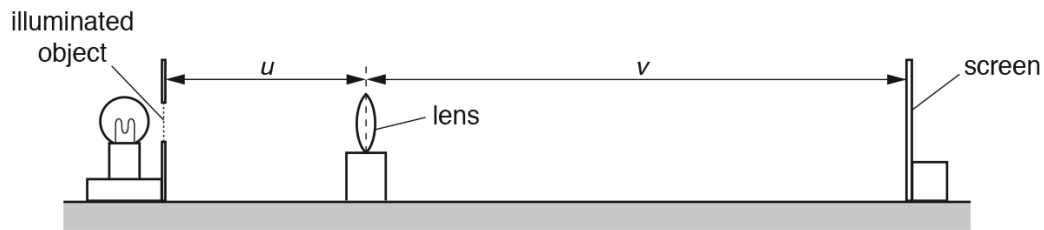

Fig. 3.1

- (a)
- The student places the screen about 100 cm from the illuminated object.
 - She places the lens between the object and the screen so that the centre of the lens is at a distance $u = 20.0$ cm from the object.
 - She adjusts the position of the screen until a clearly focused image is formed on the screen.
 - She measures the distance v between the centre of the lens and the screen.
 - She repeats the procedure using values for u of 22.0 cm, 25.0 cm, 30.0 cm and 35.0 cm.
 - The readings are shown in Table 3.1.

Table 3.1

u/cm	v/cm
20.0	60.0
22.0	47.1
25.0	37.5
30.0	29.8
35.0	26.3

Ace IGCSE
Paper Perfection, Crafted With Passion

3.2. LIGHT

Plot a graph of v/cm (y -axis) against u/cm (x -axis). You do not need to start your axes at the origin (0, 0). Draw the best-fit curve.

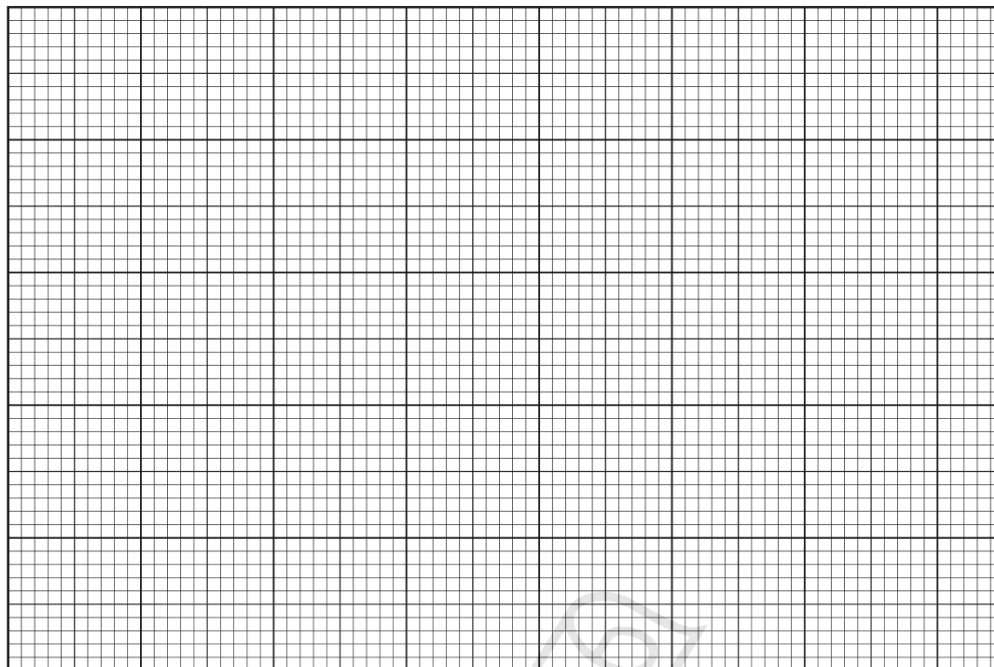

[4]

- (b) (i) • Mark, with a cross, the point on the graph grid where $u = 25.0$ cm and $v = 25.0$ cm.
 • Mark with a cross, the point on the graph grid where $u = 35.0$ cm and $v = 35.0$ cm.
 • Join these two points with a straight line. [1]

- (ii) • Record u_1 , the value of u at the point where the straight line crosses your graph line.

$u_1 = \dots\dots\dots$ cm
 • Record v_1 , the value of v at the point where the straight line crosses your graph line.
 $v_1 = \dots\dots\dots$ cm [1]

- (iii) Calculate the focal length f of the lens using the equation $f = \frac{(u_1 + v_1)}{4}$.

$f = \dots\dots\dots$ cm [2]

(c) Suggest **two** differences that you would expect to see between the appearance of the illuminated object and the image on the screen.

1.

2.

[2]

(d) Suggest **two** precautions that you would take in order to obtain reliable readings in this experiment.

1.

2.

[2]

[Total: 12]

20. 0625_w17_qp_63 Q: 4

A student has a box of converging lenses but does not know their focal lengths.

Plan an experiment which will enable her to determine an accurate value for the focal length f of one of the lenses, using the equation

$$f = \frac{uv}{(u + v)}$$

where u is the distance between an object and the lens and v is the distance between the lens and the focused image of the object.

The apparatus available includes:

- a lens holder
- a 12 V lamp in a holder, with a power supply
- a card with a triangular hole covered with tracing paper.

Write a plan for the experiment.

You should:

- list any additional apparatus needed
- draw a diagram of how the apparatus will be arranged, clearly labelling u and v
- write a method for carrying out the experiment including how f will be determined
- state the precautions which should be taken to obtain a clear, focused image
- state the precautions which should be taken to ensure that measurements are accurate once a focused image has been obtained.

21. 0625_m16_qp_62 Q: 3

- 3 A student is investigating the refraction of light by a transparent block. She uses her results to determine a quantity known as the refractive index for the material of the block.

The student's ray-trace sheet is shown in Fig. 3.1.

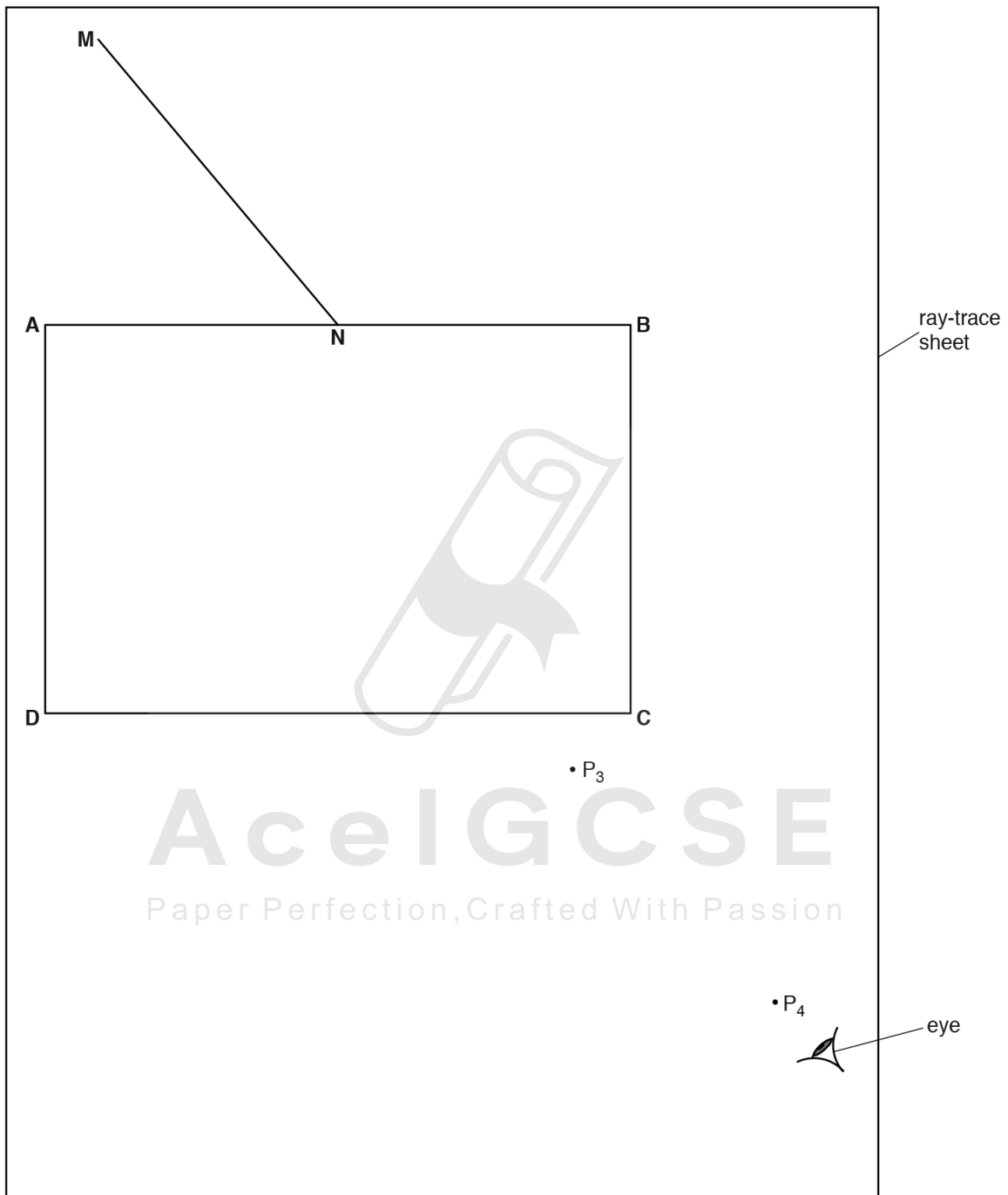

Fig. 3.1

3.2. LIGHT

(a) The student places a transparent block **ABCD** on the ray-trace sheet, as indicated in Fig. 3.1. She draws a line **NM**.

- (i) • Draw a normal to line **AB** at point **N**. The normal should start above **AB** and extend below **AB** so that it crosses line **CD**.
 - Label the point at which the normal crosses **CD** with the letter **L**.
- [1]

(ii) Measure the angle θ between the normal and line **NM**.

$\theta = \dots\dots\dots$ [1]

(b) The student places two pins P_1 and P_2 on line **NM**, a suitable distance apart.

On Fig. 3.1, mark and label appropriate positions for P_1 and P_2 . [1]

(c) The student views the images of P_1 and P_2 through the block, from the direction indicated by the eye in Fig. 3.1.

She places two pins P_3 and P_4 , as shown in Fig. 3.1, so that pins P_3 and P_4 , and the images of P_1 and P_2 , all appear exactly one behind the other.

- (i) • Draw a line joining P_3 and P_4 . Extend this line until it meets **NL**.
 - Label the point at which this line crosses **CD** with the letter **E**, and the point at which it meets **NL** with the letter **F**.
 - Draw a line joining points **N** and **E**.
 - Measure the length a of line **NE**.
- $a = \dots\dots\dots$
- Measure the length b of line **FE**.
- $b = \dots\dots\dots$
- [2]

(ii) Calculate a value n for the refractive index, using the equation $n = \frac{a}{b}$.



$n = \dots\dots\dots$ [2]

(d) Describe two precautions that you would take in order to obtain reliable results in this type of experiment.

1.
-
2.
-

[2]

[Total: 9]

22. 0625_s16_qp_61 Q: 5

A student determines the focal length of a lens.

The apparatus is shown in Fig. 5.1.

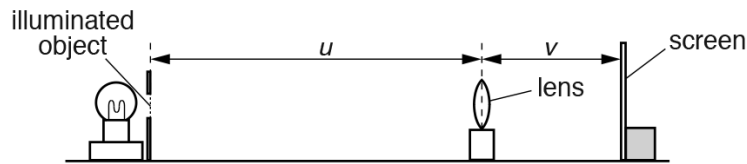

Fig. 5.1

- (a) The student places the lens at a distance u from the illuminated object. He moves the screen until a sharply focused image of the object is seen on the screen.

On Fig. 5.1,

- measure the distance u from the illuminated object to the centre of the lens,

$u = \dots\dots\dots$ mm

- measure the distance v from the screen to the centre of the lens.

$v = \dots\dots\dots$ mm

[1]

- (b) Fig. 5.1 is drawn $1/10^{\text{th}}$ actual size.

- (i) Calculate the actual distance U from the illuminated object to the centre of the lens.

$U = \dots\dots\dots$ mm

- Calculate the actual distance V from the screen to the centre of the lens.

$V = \dots\dots\dots$ mm

[1]

- (ii) Calculate a value f_1 for the focal length of the lens using the equation $f_1 = \frac{UV}{(U+V)}$.

$f_1 = \dots\dots\dots$ mm

[2]

3.2. LIGHT

- (c) A second student repeats the experiment three times using a different lens. His values for the focal length of his lens are shown in Table 5.1.

Table 5.1

	1	2	3
focal length/mm	132	141	135

Calculate the average value f_2 for the focal length of this student's lens.

$f_2 = \dots\dots\dots$ mm [1]

- (d) A third student, using the same method, finds that the focal length f of her lens is 200 mm. She reads in a book that when $u = 2f$, the distances u and v , as shown in Fig. 5.1, are equal.

- Calculate $2f$ for this student's lens.

$2f = \dots\dots\dots$ mm

The student sets up the apparatus as shown in Fig. 5.2. She adjusts both x and y to be 400 mm.

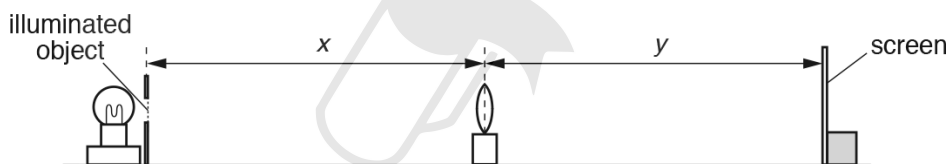

Fig. 5.2

She observes that the image is blurred. The student slowly increases the distance y , and obtains a sharply focused image when $y = 406$ mm.

Discuss whether the student's results confirm the statement in the book.

.....

.....

.....

[2]

(e) Suggest two precautions that you would take in this investigation in order to obtain reliable results.

1.

.....

2.

.....

[2]

[Total: 9]

23. 0625_s16_qp_62 Q: 3

A student is investigating the magnification of images produced by a lens.

The apparatus is shown in Fig. 3.1.

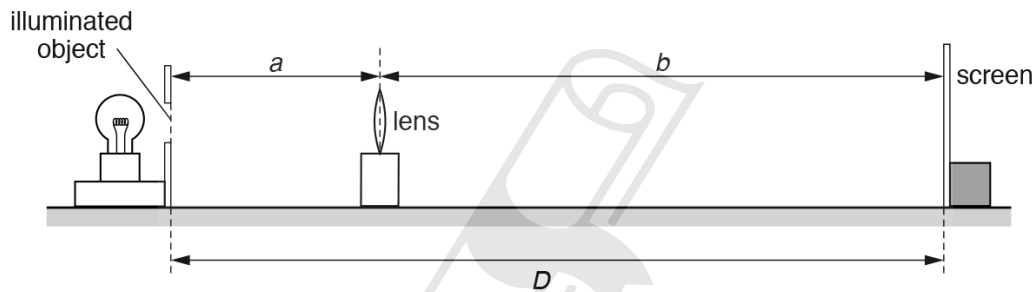

Fig. 3.1

The student places a screen at a distance $D = 80.0$ cm from an illuminated object. The screen and the illuminated object remain in the same positions throughout the experiment.

(a) She places the lens close to the illuminated object. She moves the lens until she sees a sharply focused, **enlarged** image of the object on the screen.

She measures the distance a from the illuminated object to the centre of the lens.

$$a = \dots\dots\dots 20.3 \text{ cm}$$

She measures the distance b from the centre of the lens to the screen.

$$b = \dots\dots\dots 59.7 \text{ cm}$$

Calculate the magnification m_1 of the image, using the equation $m_1 = \frac{b}{a}$.

$$m_1 = \dots\dots\dots [1]$$

3.2. LIGHT

- (b) The student then moves the lens towards the screen until a **smaller**, sharply focused image of the object is seen on the screen.

She measures the distance x from the illuminated object to the centre of the lens.

$$x = \dots\dots\dots 60.2\text{cm}$$

She measures the distance y from the centre of the lens to the screen.

$$y = \dots\dots\dots 19.8\text{cm}$$

Calculate the magnification m_2 of the image, using the equation $m_2 = \frac{y}{x}$.

$$m_2 = \dots\dots\dots [1]$$

- (c) A student suggests that $m_1 \times m_2$ should equal 1.

State whether the results support this suggestion. Justify your answer by reference to the results.

statement

justification

..... [2]

- (d) State two precautions that you would take in this experiment to obtain reliable results.

1.

2.

..... [2]

- (e) Suggest one reason why it is difficult, in this type of experiment, to decide on the best position of the lens to obtain a sharply focused image on the screen.

.....

..... [1]

[Total: 7]

24. 0625_s16_qp_63 Q: 3

A student notices that the size of the image produced by a converging lens changes when the lens is moved further away from an object.

Plan an experiment to investigate how the size of the image varies with the object distance for a converging lens suitable for school experiments.

Write a plan for the experiment, including:

- a labelled diagram of the apparatus needed
- instructions for carrying out the experiment
- the factors that will limit the range of object distances
- the graph you will plot
- one precaution you will take to ensure reliable results, explaining what might be the effect of not taking this precaution.



AceIGCSE
Paper Perfection, Crafted With Passion

25. 0625_w16_qp_61 Q: 3

A student is investigating refraction using a transparent block.

Fig. 3.1 shows the first stage of the student's ray trace. **ABCD** is the outline of the transparent block. **E** is at the centre of **AB** and **G** is at the centre of **CD**.

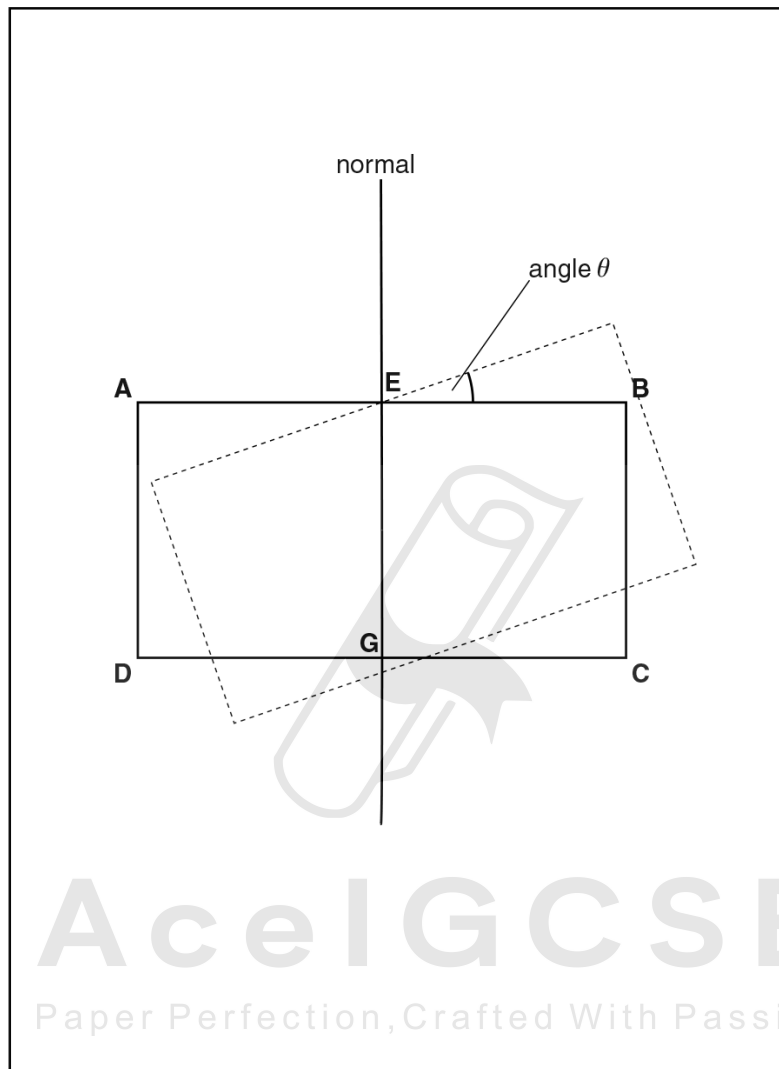

Fig. 3.1

3.2. LIGHT

(a) On Fig. 3.1, draw a line **FE** to the left of the normal, above the outline of the block, and at an angle $i = 20^\circ$ to the normal. [1]

- (b) • The student places a pin P on the line **FE**, at a suitable distance from the block.
- There is a vertical line L_1 drawn on side **AB** of the block at point **E**. There is a second vertical line L_2 drawn on side **CD** at point **G**.
 - The student observes the images of L_1 and P through side **CD** of the block. He carefully turns the block to the dashed position in Fig. 3.1. In this position the vertical line L_2 and the images of L_1 and P appear one behind the other.

(i) On Fig. 3.1, mark with a cross (x) a suitable position for pin P. [1]

(ii) Explain briefly the experimental reason for your choice of position for pin P.

.....

.....

.....[1]

(iii) On Fig. 3.1, measure the angle θ and enter it in the first row of Table 3.1, on page 10. [1]



- (c) • The student measures the angle θ between the original position of **AB** and the new position of **AB**, as indicated in Fig. 3.1.
- He repeats the procedure, using values of $i = 30^\circ, 40^\circ, 50^\circ$ and 60° .
- The readings are shown in Table 3.1.

Table 3.1

$i/^\circ$	$\theta/^\circ$
20	
30	29
40	41
50	51
60	59

Plot a graph of $\theta/^\circ$ (y-axis) against $i/^\circ$ (x-axis).

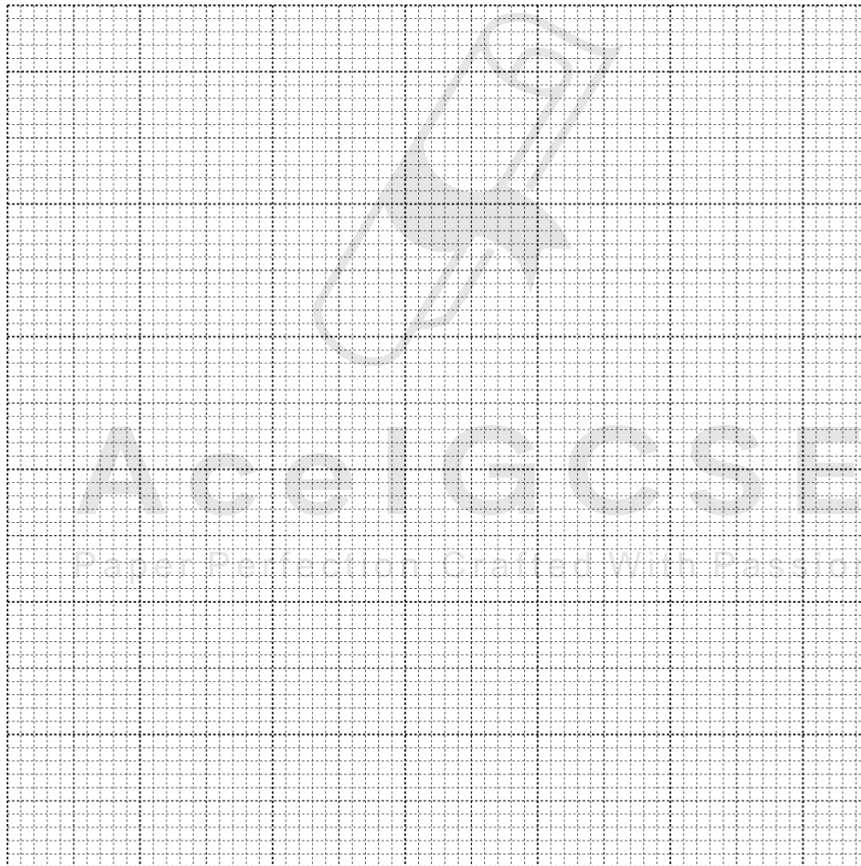

[4]

3.2. LIGHT

- (d) Determine the gradient G of the graph. Show clearly on the graph how you obtained the necessary information.

$G = \dots\dots\dots[2]$

[Total: 10]



Ace | GCSE
Paper Perfection, Crafted With Passion

26. 0625_w16_qp_62 Q: 5

A student is investigating reflection using a plane mirror.

Fig. 5.1 shows the student's ray-trace sheet.

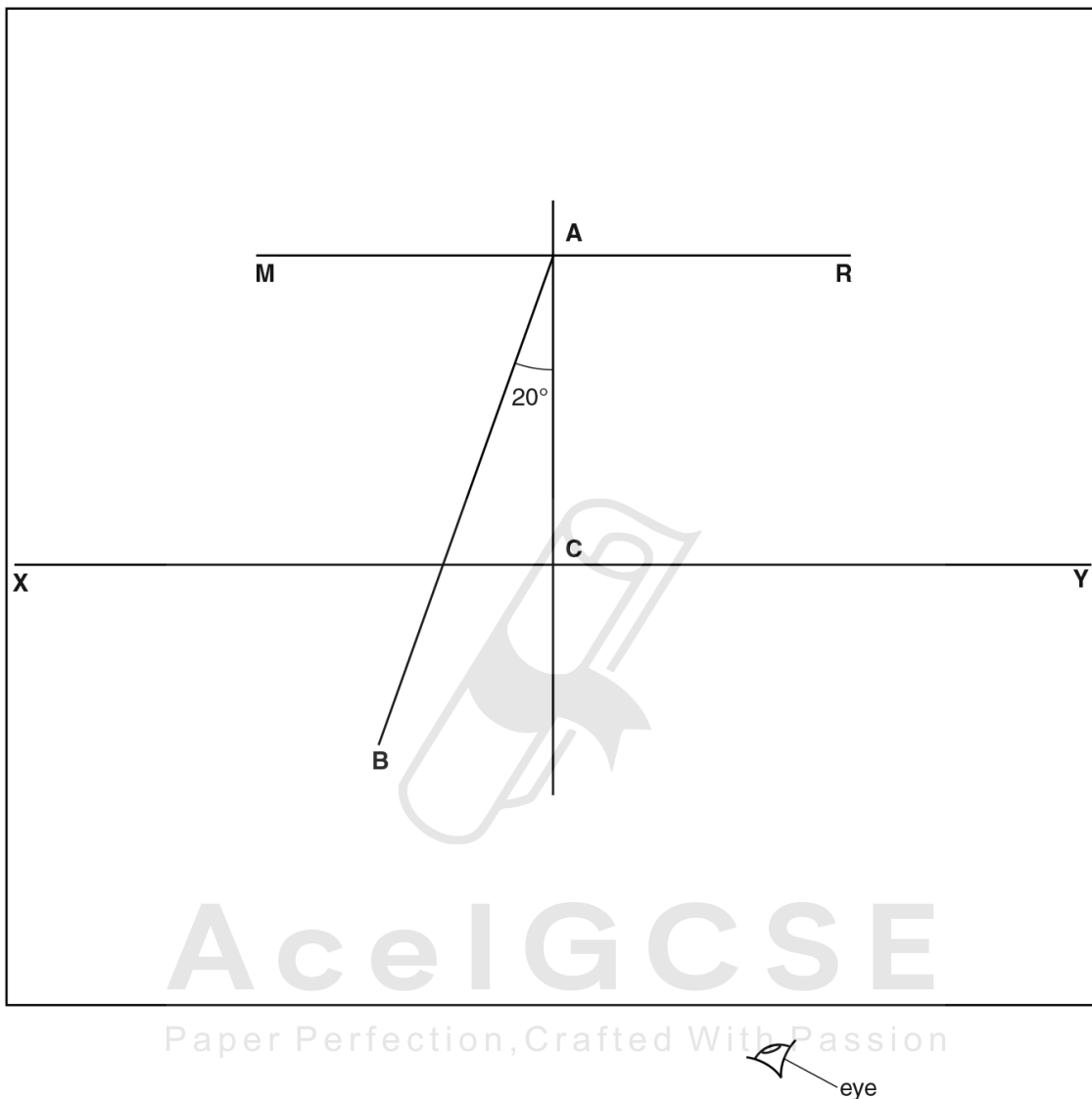

Fig. 5.1

- (a) The line **MR** marks the position of the mirror. The student draws another line **XY** parallel to line **MR**. He draws a line from **A** at an angle of incidence $i = 20^\circ$. He labels the end of this line **B**. The student places a pin P_1 at point **B**. He places a pin P_2 on line **AB** at a suitable distance from pin P_1 to produce a ray trace.

- (i) On Fig. 5.1, measure the length l of line **AB**.

$l = \dots\dots\dots$ [1]

- (ii) On Fig. 5.1, mark with a cross (x) a suitable position for pin P_2 . [1]

3.2. LIGHT

- (b) The student views the images of pins P_1 and P_2 from the direction indicated by the eye in Fig. 5.1. He places two pins P_3 and P_4 , a suitable distance apart, so that pins P_3 and P_4 and the images of P_2 and P_1 , all appear exactly one behind the other.

He draws a line joining the positions of P_3 and P_4 . He labels the point at which this line crosses XY with the letter D . He measures the distance d between C and D .

He repeats the procedure using i values of 0° , 30° , 40° , 50° and 60° . The readings are shown in Table 5.1.

Table 5.1

$i/^\circ$	d/cm
0	0.0
20	1.8
30	2.9
40	4.2
50	6.0
60	8.7

Plot a graph of d/cm (y -axis) against $i/^\circ$ (x -axis).

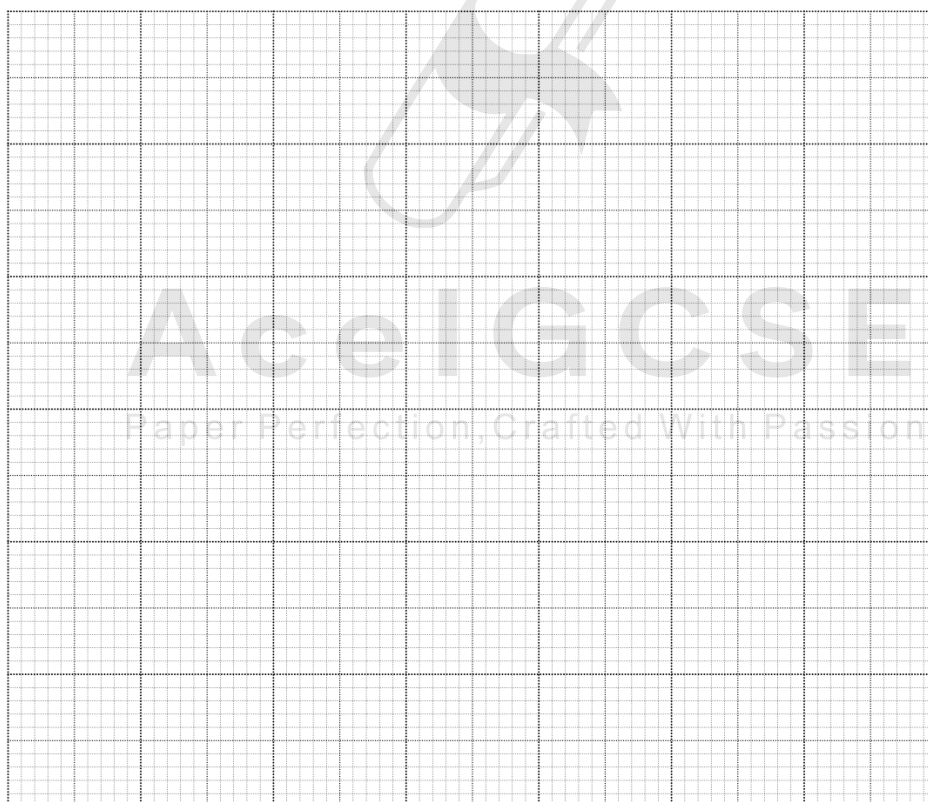

[4]

- (c) A student suggests that i should be directly proportional to d .

State whether the graph supports this suggestion. Justify your answer by reference to the graph.

statement

justification

.....

[2]

- (d) Suggest two practical difficulties in obtaining accurate readings in this experiment.

1.

.....

2.

.....

[2]

[Total: 10]



Ace | GCSE
Paper Perfection, Crafted With Passion

3.2. LIGHT

27. 0625_w16_qp_63 Q: 2

Some students are determining the focal length of a converging lens by two different methods.

They are using the apparatus shown in Fig. 2.1.

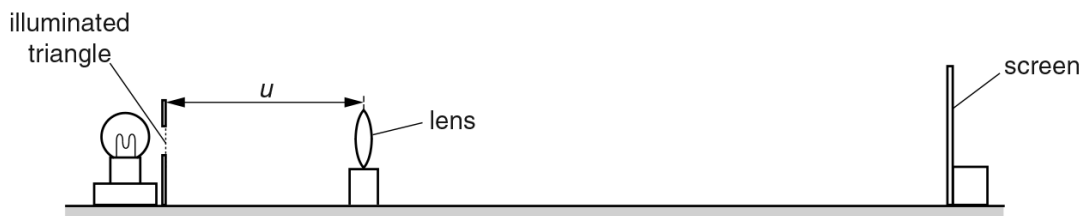

Fig. 2.1

(a) A student sets the distance u between the illuminated triangle and the lens to 20.0 cm. She moves the screen until a sharp image of the triangle is seen on the screen.

- (i) • Measure h_o , the height of the illuminated triangle, as shown in Fig. 2.2.

$h_o = \dots\dots\dots$

- Measure h_I , the height of the image on the screen, as shown in Fig. 2.3.

$h_I = \dots\dots\dots$ [2]

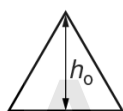

Fig. 2.2

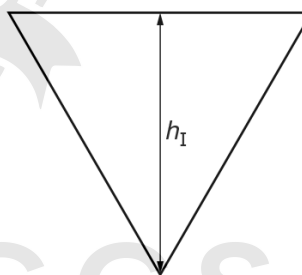

Fig. 2.3

- (ii) Calculate a value M for the magnification, using the equation $M = \frac{h_I}{h_o}$.

$M = \dots\dots\dots$ [1]

- (iii) Calculate a value for the focal length f_1 of the lens, using the equation $f_1 = \frac{uM}{(M + 1)}$, where $u = 20.0$ cm.

$f_1 = \dots\dots\dots$ [2]

- (iv) Describe one difficulty that might be experienced when measuring the height of the image. Suggest an improvement to the apparatus to overcome this.

difficulty

.....

improvement

.....

[2]

- (b) The student adjusts the position of the lens so that $u = 40.0$ cm.

She moves the screen until a sharp image of the triangle is again seen on the screen. Fig. 2.4 is a scale diagram showing her result.

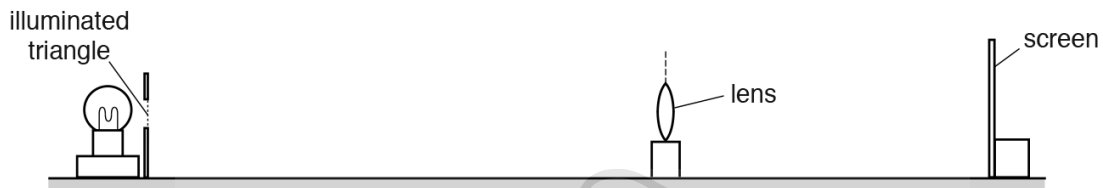

Fig. 2.4

- (i) • On Fig. 2.4, measure the distance between the lens and the screen.
distance =

- Fig. 2.4 is drawn to 1/5th scale.

Determine the actual distance v between the lens and the screen in the experiment.

$v =$

[1]

3.2. LIGHT

- (ii) • Calculate a second value f_2 for the focal length of the lens, using the equation

$$f_2 = \frac{uv}{(u+v)}, \text{ where } u = 40.0 \text{ cm.}$$

$f_2 =$

- The student suggests that f_1 and f_2 should be equal.

State whether the results support this suggestion. Justify your statement with reference to the results.

.....
.....
.....

[2]

- (c) State one precaution, not included in your answer to (a)(iv), that you would take to make the experiment reliable.

.....
.....

[1]

[Total: 11]

28. 0625_m15_qp_62 Q: 4

A student is carrying out an experiment with a small converging lens. The student sets up the apparatus as shown in Fig. 4.1. The distances are shown full size.

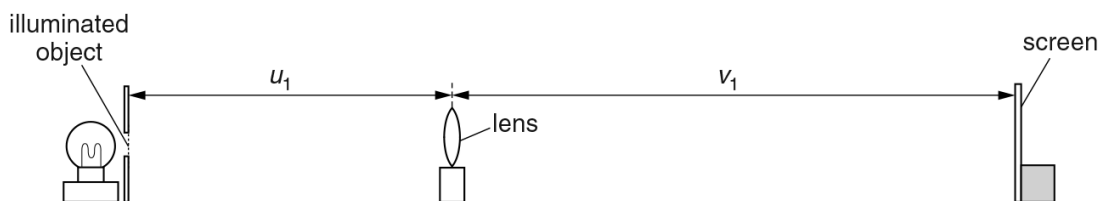

Fig. 4.1

- (a) She moves the screen until a sharp image of the illuminated object appears on the screen.
- (i) Using Fig. 4.1, measure and record the distance u_1 between the illuminated object and the lens, and the distance v_1 between the lens and the screen.

$u_1 =$

$v_1 =$ [2]

- (ii) Calculate a value for the focal length f of the lens, using your results from (a)(i) and the equation $f = \frac{u_1 v_1}{(u_1 + v_1)}$.

$f =$ [2]

- (b) Keeping the illuminated object and screen in the same positions, she moves the lens towards the screen until a second sharp image is seen on the screen. The distances are shown full size.



Fig. 4.2

- (i) Using Fig. 4.2, measure and record the new distance u_2 between the illuminated object and the lens.

$u_2 =$

3.2. LIGHT

(ii) The student suggests that u_2 and v_1 should be equal.

State whether the lens positions obtained by the student support this suggestion. Justify your statement by reference to the results.

statement

justification

.....

.....

[2]

(c) Describe two precautions that should be taken in order to obtain reliable results in this type of experiment.

1.

.....

2.

.....

[2]

[Total: 8]



29. 0625_s15_qp_61 Q: 4

The class is investigating the refraction of light passing through a transparent block.

Fig. 4.1 shows a student's ray-trace sheet.

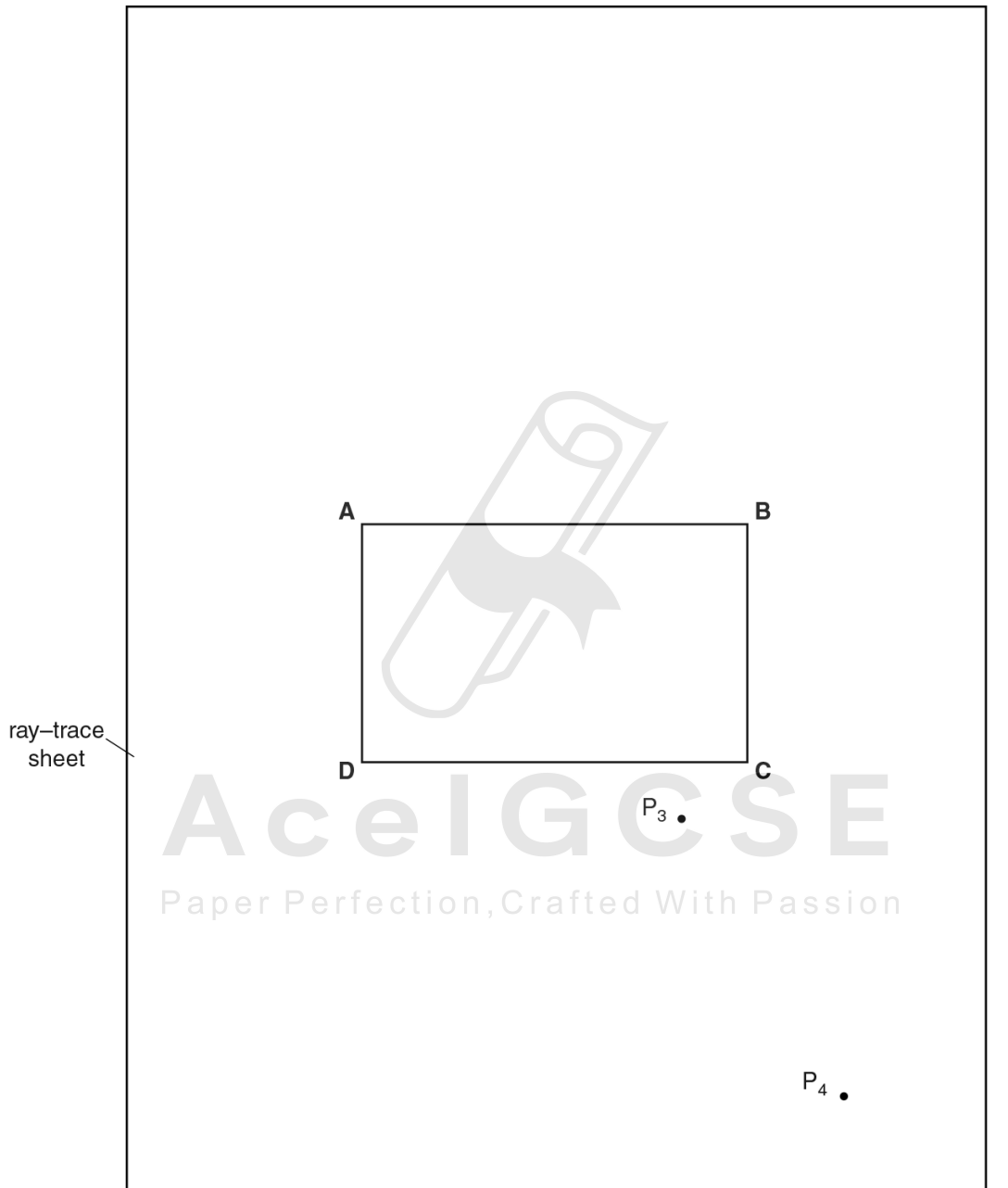

Fig. 4.1

3.2. LIGHT

A student draws the outline **ABCD** of a transparent block.

- (a) (i) Draw a normal **NL** at the centre of side **AB**. Label the point **E** where the normal crosses **AB**. Label the point **M** where the normal crosses **CD**.
- (ii) Draw a line **GH**, parallel to **AB** and 6.0 cm above **AB**. Label the point **J** where the normal crosses **GH**.
- (iii) Draw a line, starting at **E**, to the left of the normal and at an angle of incidence $i = 30^\circ$ to the normal. Label the point **F** where the line meets **GH**.

[3]

- (b) The student places two pins P_1 and P_2 on the line **FE**.

On Fig. 4.1, label suitable positions for pins P_1 and P_2 .

[1]

- (c) The student observes the images of P_1 and P_2 through side **CD** of the block so that the images of P_1 and P_2 appear one behind the other.

She places two pins P_3 and P_4 between her eye and the block so that P_3 and P_4 , and the images of P_1 and P_2 seen through the block, appear one behind the other. The positions of P_3 and P_4 are shown on Fig. 4.1.

- (i) Draw a line joining the positions of P_3 and P_4 . Continue the line until it meets **CD** and label this point **K**.

- (ii) Draw the line **KE**.

[1]

- (d) (i) Measure and record the length a between points **F** and **J**.

$a =$

- (ii) Measure and record the length b between points **F** and **E**.

$b =$

- (iii) Measure and record the length c between points **E** and **K**.

$c =$

- (iv) Measure and record the length d between points **M** and **K**.

$d =$

[1]

- (v) Calculate n , the refractive index of the material of the block, using the equation $n = \frac{ac}{bd}$.

$n =$ [1]

(e) Suggest one precaution that you would take with this experiment to obtain reliable results.

.....
.....
.....[1]

(f) Fig. 4.2 shows a ray box.

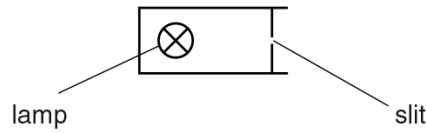

Fig. 4.2

This experiment can be carried out using a ray box instead of the pins.

On Fig. 4.1, draw a ray box in a suitable position for this experiment.

[1]

[Total: 9]



3.2. LIGHT

30.0625_s15_qp_62 Q: 4

The class is investigating reflection using a plane mirror.

Fig. 4.1 shows a student's ray-trace sheet. The student uses an A4 sheet of plain paper.

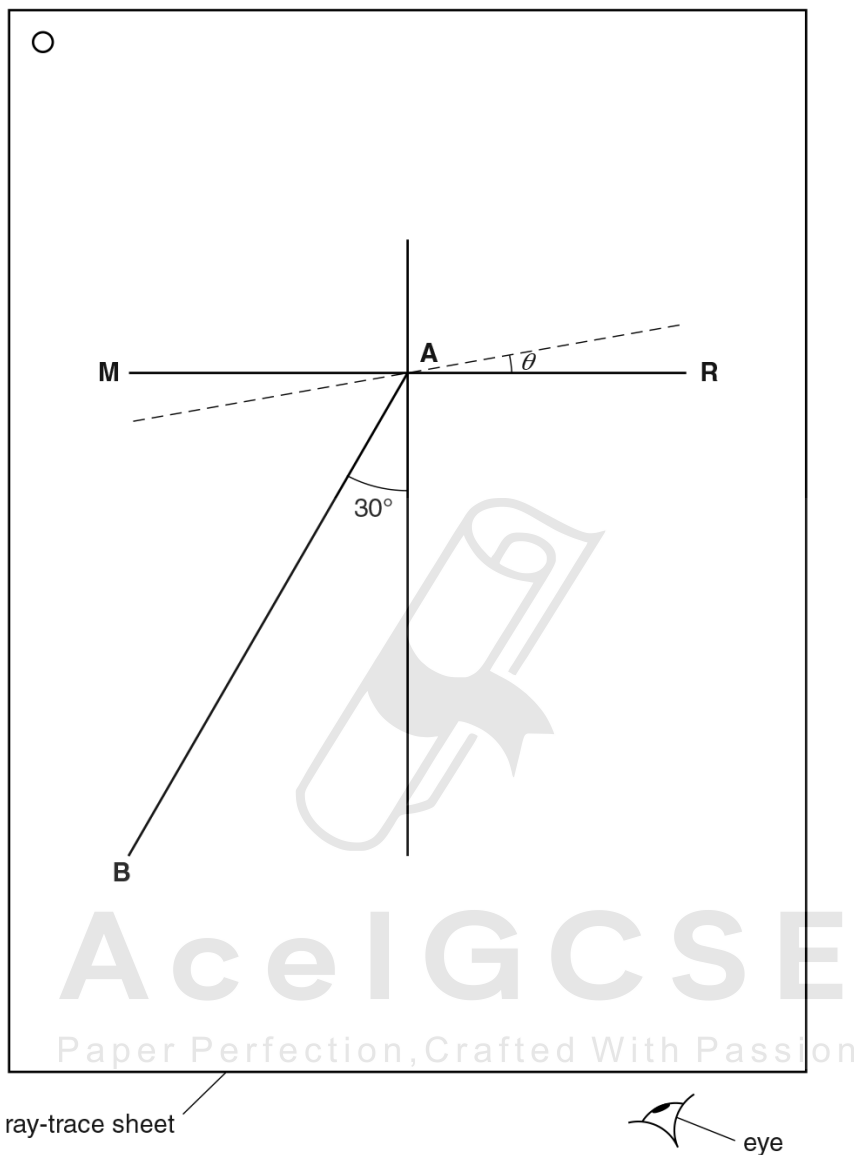

Fig. 4.1

- (a) On Fig. 4.1, the mirror is placed along the line **MR**. Label the normal **NL**. [1]
- (b) The student places two pins P_1 and P_2 on line **AB** at a suitable distance apart, so that she can accurately observe the reflection of line **AB**.

Suggest a suitable distance between the two pins.

distance =[1]

- (c) The student determines the angle between the reflected ray and the normal by viewing the images of pins P_1 and P_2 from the direction indicated by the eye in Fig. 4.1. She places two pins P_3 and P_4 , some distance apart, so that pins P_3 and P_4 , and the images of P_2 and P_1 , all appear exactly one behind the other. She draws a line joining the positions of P_3 and P_4 .

She measures the angle α between the normal and the line joining the positions of P_3 and P_4 . At this stage the angle θ between the mirror and line **MR** is 0° , as shown in Table 4.1.

She moves the mirror to a new position, shown by the dotted line on Fig. 4.1, at an angle $\theta = 10^\circ$ to **MR**. She repeats the procedure with pins P_3 and P_4 .

She continues using angles $\theta = 20^\circ, 30^\circ$ and 40° . The readings are shown in Table 4.1.

Table 4.1

$\theta/^\circ$	$\alpha/^\circ$
0	32
10	50
20	69
30	92
40	108

- (i) Plot a graph of $\alpha/^\circ$ (y-axis) against $\theta/^\circ$ (x-axis).

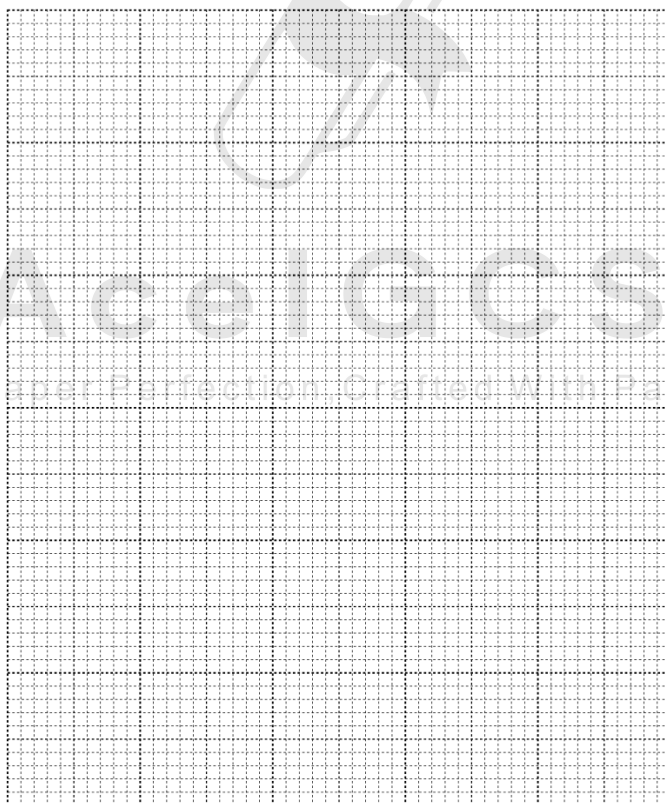

[5]

3.2. LIGHT

- (ii) State whether your graph line shows that the angle α is directly proportional to the angle θ . Justify your statement by reference to your graph line.

statement

justification

.....

[2]

- (iii) Suggest why, when this experiment is carried out carefully, the points plotted may not all lie on the graph line.

.....

.....[1]

[Total: 10]



Ace | GCSE
Paper Perfection, Crafted With Passion

31. 0625_s15_qp_62 Q: 5

The class is investigating the image formed by a converging lens.

Fig. 5.1 shows the experimental set up.

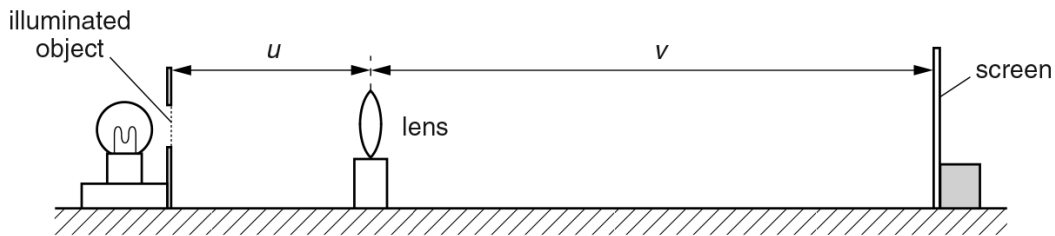

Fig. 5.1

A student positions the illuminated object and the lens and then moves the screen away from the lens until a sharply focused image of the object is formed on the screen.

The student measures the distances u and v , as shown in Fig. 5.1.

$u = \dots\dots\dots 25.8 \text{ cm}$

$v = \dots\dots\dots 36.2 \text{ cm}$

- (a) Calculate the focal length f of the lens using the equation $f = \frac{uv}{(u + v)}$. Give your answer to a suitable number of significant figures for this experiment.

$f = \dots\dots\dots [2]$

- (b) State two precautions you would take in the laboratory in order to obtain reliable measurements when doing this experiment.

1.

2.

[2]

3.2. LIGHT

(c) The object in Fig. 5.1 is an illuminated triangle, as shown in Fig. 5.2.



Fig. 5.2

Suggest two differences between the appearance of the illuminated object and the well-focused image on the screen.

1.

2.

[2]

[Total: 6]



Ace | GCSE
Paper Perfection, Crafted With Passion

32. 0625_s15_qp_63 Q: 4

A student is determining the focal length of a converging lens by two methods.

First, he uses the apparatus shown in Fig. 4.1.

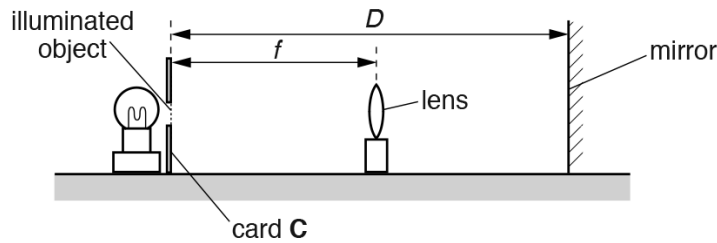

Fig. 4.1

- (a) He sets the distance D between the mirror and the illuminated object to 30.0 cm.

He then moves the lens until a sharp image appears on card **C** by the side of the illuminated object.

- (i) On Fig. 4.1, measure the distance f between the illuminated object and the lens.

$f = \dots\dots\dots$ [1]

- (ii) Fig. 4.1 is drawn to $1/5^{\text{th}}$ scale.

Calculate, and record in Table 4.1, the actual distance F between the illuminated object and the lens. F is a value for the focal length of the lens in this experiment.

Table 4.1

D/cm	F/cm
30.0	
50.0	15.7

[1]

- (b) The student repeats the procedure for a distance $D = 50.0$ cm. His result is shown in the table.

Use the results from the table to calculate F_1 , an average value of F .

$F_1 = \dots\dots\dots$ [1]

3.2. LIGHT

(c) The student arranges the lens, illuminated object and a screen as shown in Fig. 4.2.

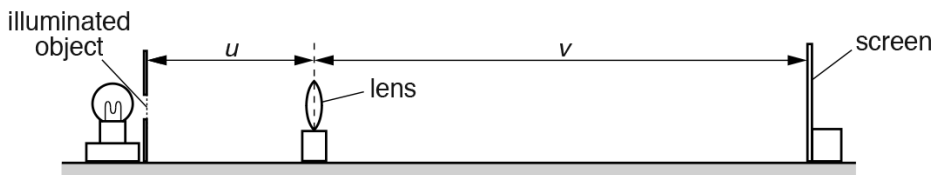

Fig. 4.2

He measures the distance u between the illuminated object and the lens.

He moves the screen until a sharp image of the illuminated object appears on the screen, and measures the distance v between the lens and the screen.

His readings are: $u = \dots\dots\dots 20.0 \text{ cm} \dots\dots\dots$
 $v = \dots\dots\dots 72.5 \text{ cm} \dots\dots\dots$

(i) Calculate F_2 , another value for the focal length of the lens, using the student's results and the equation $F_2 = \frac{uv}{(u + v)}$.

$F_2 = \dots\dots\dots [1]$

(ii) A student suggests that F_1 and F_2 should be equal.

State whether your findings support this idea. Justify your statement by reference to the results.

statement $\dots\dots\dots$

justification $\dots\dots\dots$

AcelGCSE

[2]

(d) Describe a precaution that you would take in order to obtain reliable results in this experiment.

$\dots\dots\dots$
 $\dots\dots\dots [1]$

[Total: 7]

33. 0625_w15_qp_61 Q: 3

The class is investigating reflection using a plane mirror.

Fig. 3.1. shows a student's ray-trace sheet.

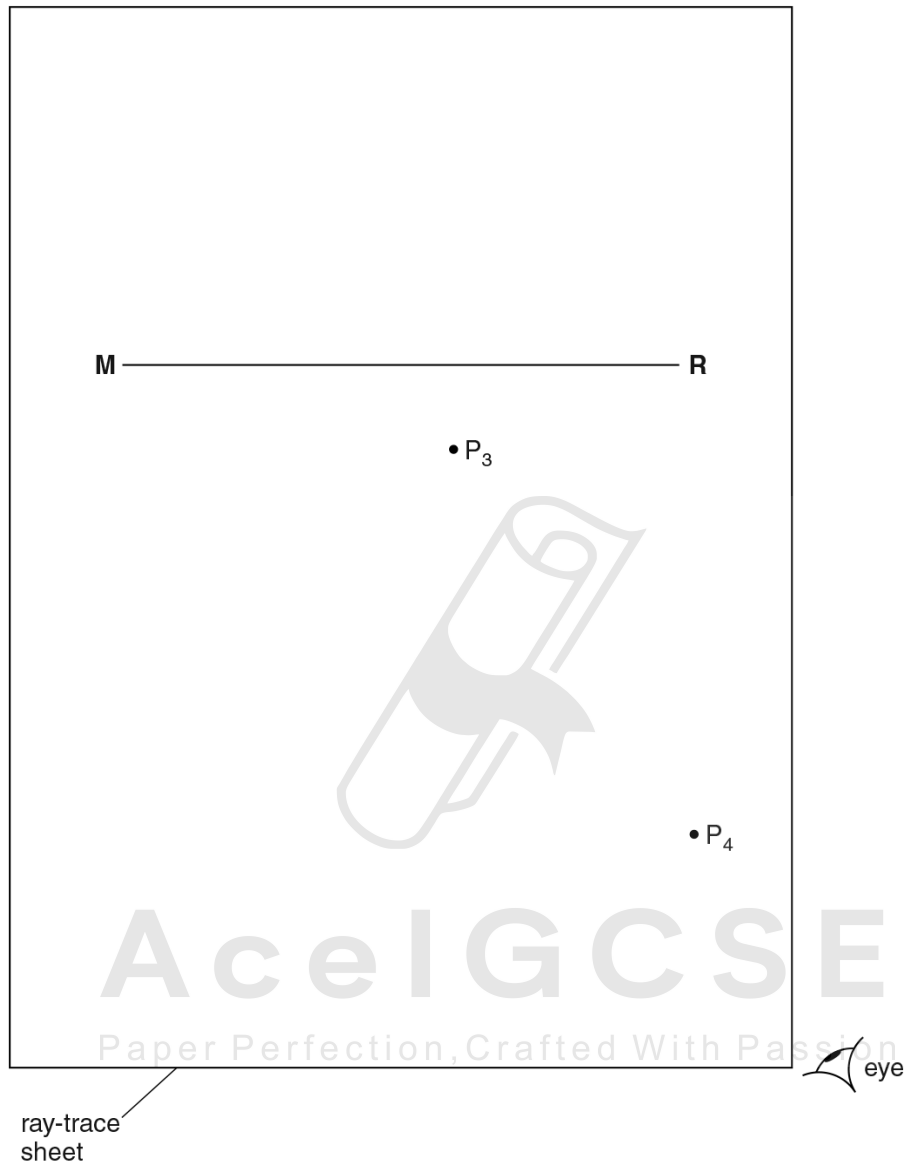

Fig. 3.1

3.2. LIGHT

- (a) The student draws the line **MR** to mark the position of a plane mirror.
 - (i) Draw a normal to this line that passes through its centre. Label the normal **NL**. Label the point at which **NL** crosses **MR** with the letter **A**.
 - (ii) Draw a line 8.0 cm long from **A** at an angle of incidence $i = 30^\circ$ to the normal, below **MR** and to the left of the normal. Label the end of this line **B**.

[3]

- (b) The student places a pin P_1 at point **B**. He places a second pin P_2 on line **AB**.

Label a position **X** on line **AB** to show a suitable position for pin P_2 .

[1]

- (c) He views the images of pins P_1 and P_2 from the direction indicated by the eye in Fig. 3.1. He places two pins P_3 and P_4 , a suitable distance apart, so that pins P_3 and P_4 , and the images of P_2 and P_1 , all appear exactly one behind the other. The positions of P_3 and P_4 are shown in Fig. 3.1.

- (i) Draw the line joining the positions of P_3 and P_4 . Extend the line until it meets **NL**.

- (ii) Measure the angle r between **NL** and the line joining the positions of P_3 and P_4 .

$r =$ [2]

- (d) State two precautions that you would take in this experiment in order to obtain reliable readings.

1.
.....
2.
.....

[2]

- (e) A student has done this experiment very carefully, taking these precautions.

She is disappointed to find that her line for the reflected ray is not exactly where she predicts from the theory.

Suggest a practical reason for this.

.....
.....[1]

[Total: 9]

34. 0625_w15_qp_61 Q: 5

The class is doing a lens experiment.

Fig. 5.1 shows some of the apparatus used.

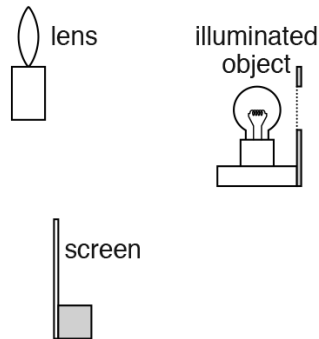

Fig. 5.1

- (a) Draw a diagram to show how the apparatus shown in Fig. 5.1 is arranged for an experiment to determine the focal length of the lens. The laboratory bench is drawn for you.



[2]

- (b) The focal length of the lens is known to be approximately 15 cm.

Suggest a suitable distance d between the illuminated object and the screen so that a well-focused image can be seen on the screen.

$d = \dots\dots\dots$ cm [1]

- (c) Suggest two practical difficulties that may cause inaccuracy in the value of focal length obtained.

1.
2.

[2]

3.2. LIGHT

(d) Fig. 5.2 shows the shape of the illuminated object.

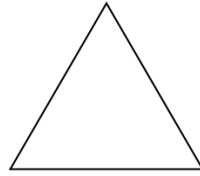

Fig. 5.2

In the space below, draw a diagram to show the focused image that you would expect to see on the screen. [1]

[Total: 6]

35. 0625_w15_qp_62 Q: 4

The class is investigating reflection using a plane mirror.

Fig. 4.1 shows a student's ray-trace sheet.

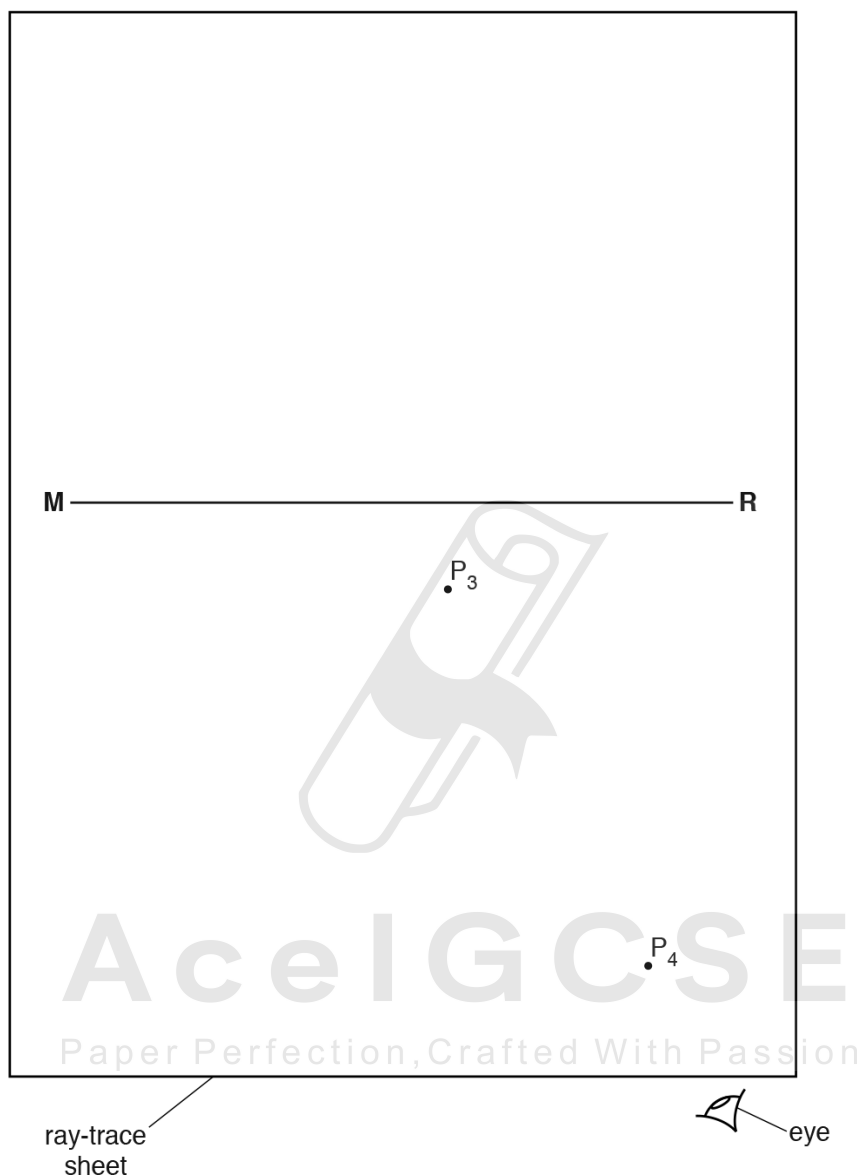

Fig. 4.1

- (a) The student draws the line **MR** to mark the position of a plane mirror.
- (i) On Fig. 4.1, draw a normal to this line that passes through its centre. Label the normal **NL**. Label the point at which **NL** crosses **MR** with the letter **A**.
- (ii) Draw a line 8.0 cm long from **A** at an angle of incidence $i = 30^\circ$ to the normal, below **MR** and to the left of the normal. Label the end of this line **B**.

[3]

3.2. LIGHT

- (b) The student places a pin P_1 at point **B**. She places a second pin P_2 on line **AB**.

Label a position **X** on line **AB** to show a suitable position for pin P_2 . [1]

- (c) She views the images of pins P_1 and P_2 from the direction indicated by the eye in Fig. 4.1. She places two pins P_3 and P_4 , some distance apart, so that pins P_3 and P_4 , and the images of P_2 and P_1 , all appear exactly one behind the other. The positions of P_3 and P_4 are shown in Fig. 4.1.

- (i) Draw the line joining the positions of P_3 and P_4 . Extend the line until it meets **NL**.

- (ii) Measure the angle r between **NL** and the line joining the positions of P_3 and P_4 .

$r =$ [2]

- (d) State two precautions that you would take with the pins in this experiment in order to obtain reliable readings.

1.
.....
2.
.....

[2]



- (e) The student turns the ray-trace sheet through 180° . She draws a line **AC** at an angle of incidence $i = 30^\circ$ to the normal, below **MR** and to the right of the normal.

She repeats the procedure described in parts (b) and (c). Her ray-trace is shown in Fig. 4.2.

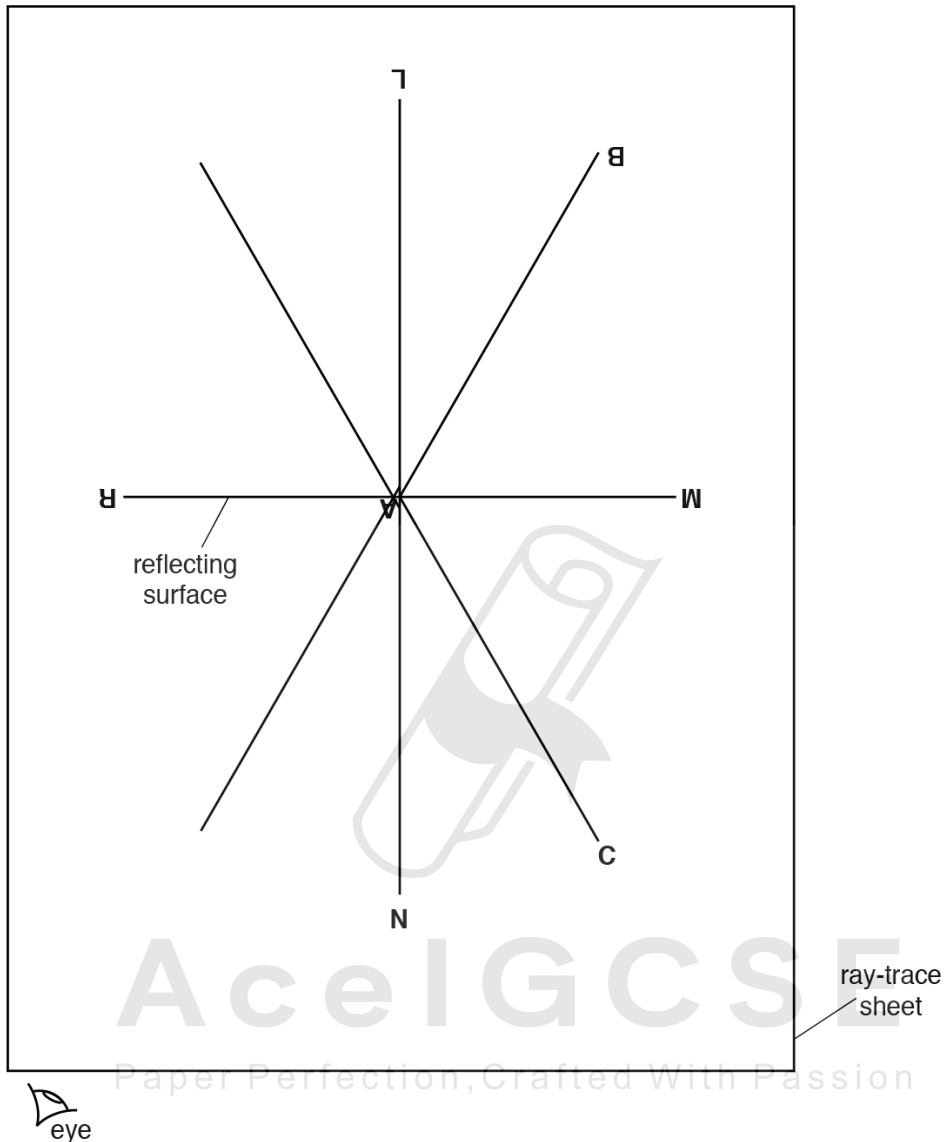

Fig. 4.2

She carried out the experiment very carefully. She expected that the results would show all the incident rays and reflected rays meeting at point **A**.

Suggest a practical reason why the lines may not meet exactly at point **A**.

.....
[1]

[Total: 9]

3.2. LIGHT

36. 0625_w15_qp_63 Q: 5

A student is investigating the refraction of light in a transparent block. Her ray-trace will be used to determine a quantity known as the refractive index of the material of the block.

Fig. 5.1 shows her ray-trace sheet.

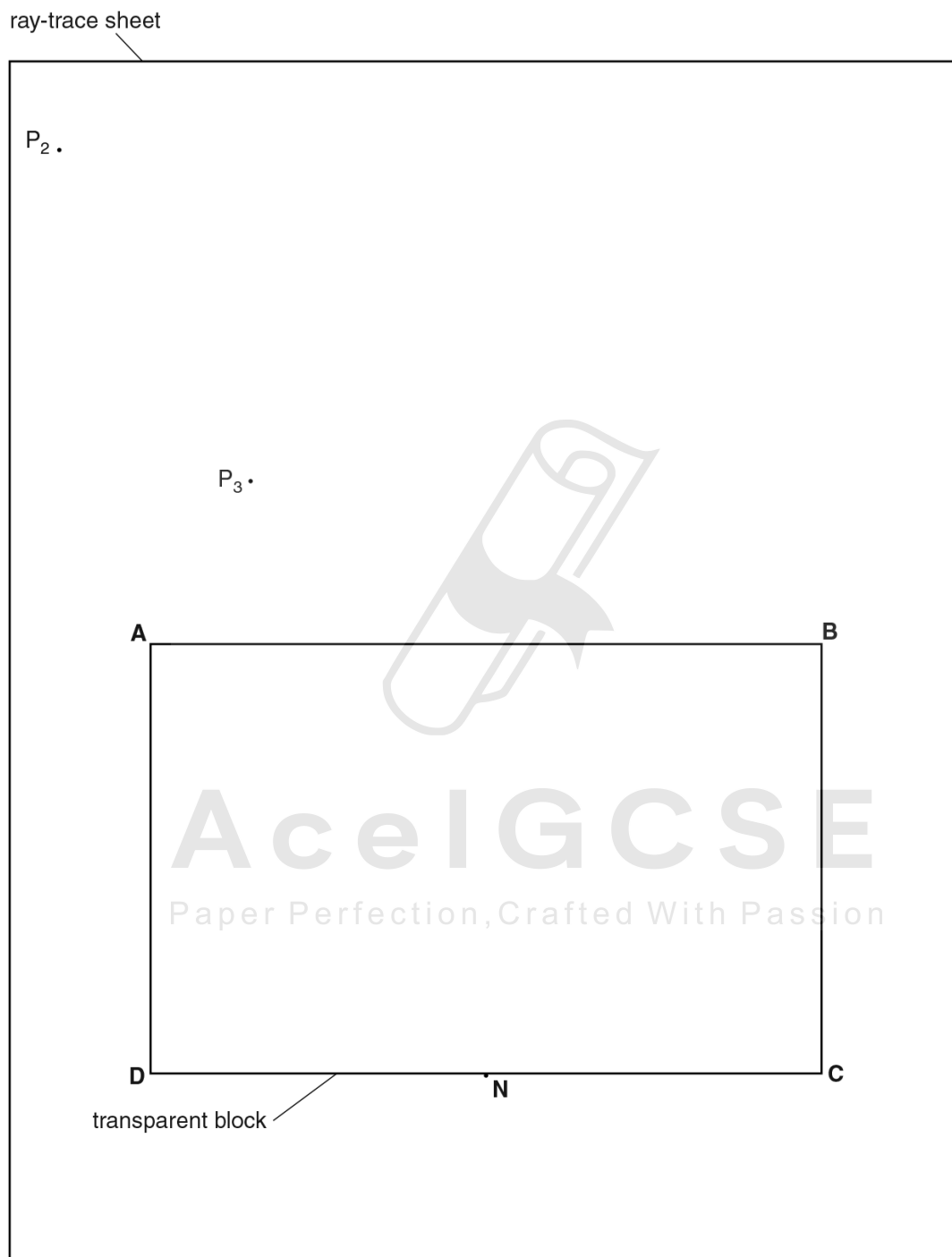

Fig. 5.1

The student draws the outline **ABCD** of the transparent block.

- (a) Draw a normal to the line **DC** through point **N**. Extend the normal beyond line **AB**.

Label the upper end of the normal with the letter **L**. Label the point at which **NL** crosses **AB** with the letter **E**. [1]

- (b) The student places a pin P_1 against the block at point **N** and views the image of P_1 through the side **AB** of the block.

She places two pins P_2 and P_3 , as shown in Fig. 5.1, so that pins P_2 and P_3 , and the image of P_1 , all appear exactly one behind the other.

- (i) Draw a line joining the positions of P_2 and P_3 . Extend this line until it crosses **NL**. Label the point at which the line crosses **NL** with the letter **F**. [1]

- (ii) Measure the length a of line **EN**.

$a = \dots\dots\dots$

- (iii) Measure the length b of line **EF**.

$b = \dots\dots\dots$

[2]

- (c) Calculate a value n for the refractive index of the block, using your values from (b)(ii) and (b)(iii) and the equation $n = \frac{a}{b}$.

$n = \dots\dots\dots$ [1]

- (d) Suggest a practical precaution that you would take to ensure a reliable result in this type of experiment.

.....
 [1]

3.2. LIGHT

- (e) The student obtains a second value for the refractive index n by repeating the experiment with the block standing on edge, as shown in Fig. 5.2.

She views the image of P_1 from the direction indicated by the arrow. The block is 1.5 cm thick.

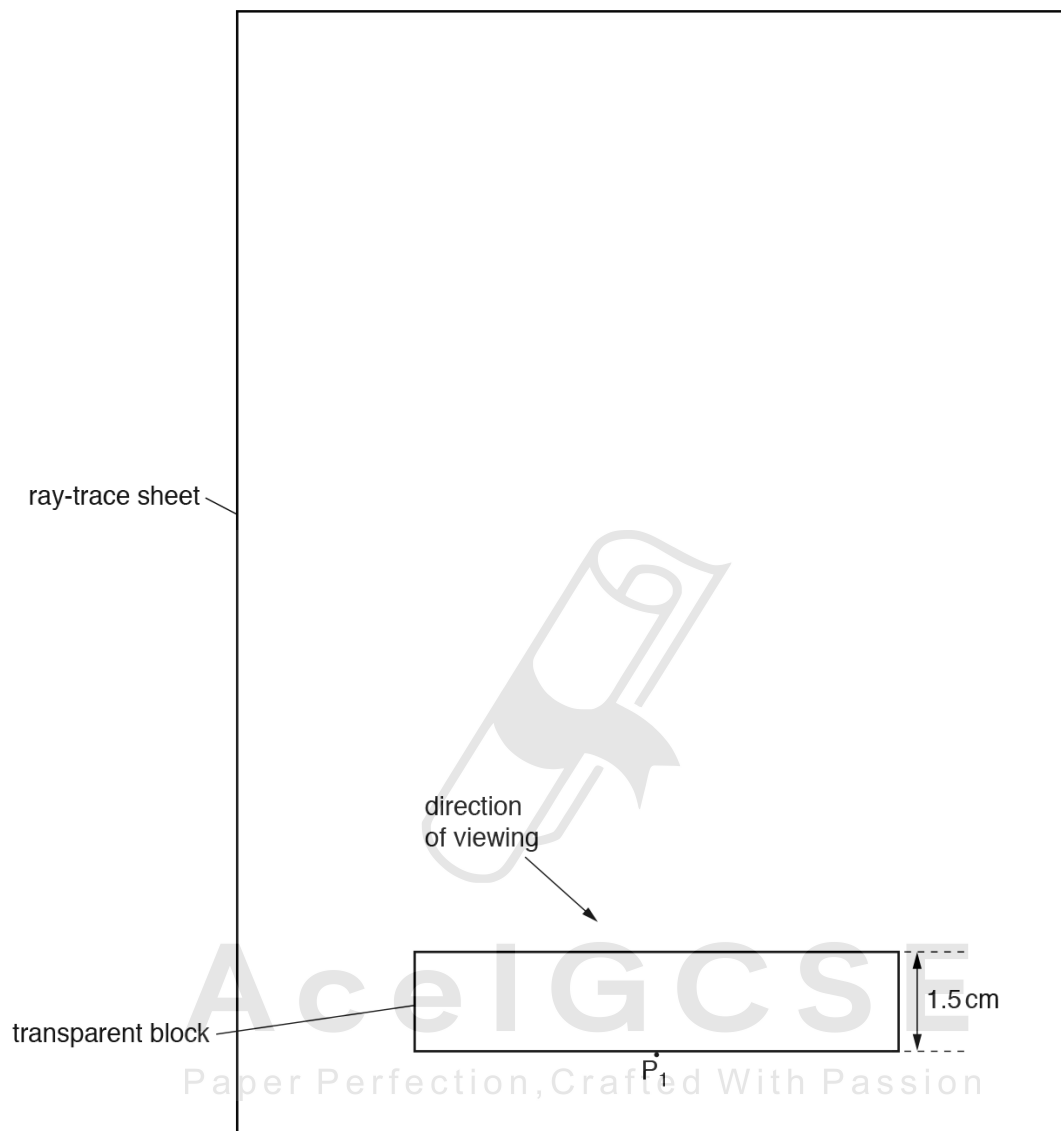

Fig. 5.2

State and explain whether this value for the refractive index is likely to be more or less reliable than the value n obtained for the refractive index in part (c).

statement

explanation

.....

.....

[2]

[Total: 8]



Ace | GCSE
Paper Perfection, Crafted With Passion

3.2. LIGHT

37.0625_s14_qp_61 Q: 5

The IGCSE class is investigating reflection using a plane mirror.

Fig. 5.1 shows a student's ray-trace sheet with a line **MR** drawn on it. In the experiment the reflecting face of a mirror is placed vertically on the line **MR**. The additional dashed line shows a second mirror position.

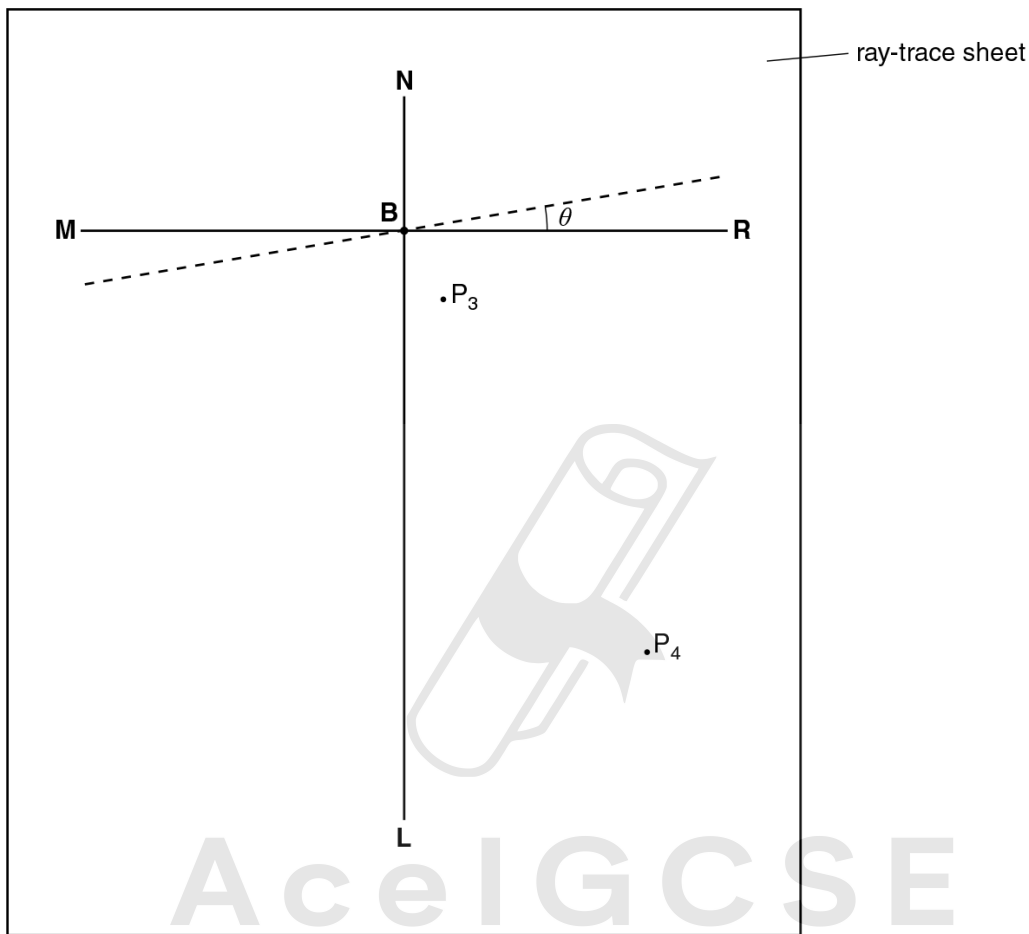

AcelGCSE
Paper Perfection Crafted With Passion

Fig. 5.1

- (a) **NL** is a normal to line **MR**. Draw a line 8.0 cm long from **B** at an angle of incidence $i = 30^\circ$ to the normal, below **MR** and to the left of the normal. Label the end of this line **A**. [1]
- (b) The student places two pins, P_1 and P_2 , on line **AB** a suitable distance apart for this ray tracing experiment. He views the images of pins P_1 and P_2 in the mirror and places two pins P_3 and P_4 so that pins P_3 and P_4 , and the images of P_2 and P_1 , all appear exactly one behind the other. The positions of P_3 and P_4 are shown in Fig. 5.1.
 - (i) Draw the line joining the positions of P_3 and P_4 . Extend the line until it meets **NL**.
 - (ii) Measure the angle α_0 between **NL** and the line joining the positions of P_3 and P_4 . At this stage the angle θ between the mirror and line **MR** is 0° .

$\alpha_0 = \dots\dots\dots$ [2]

- (c) The student draws lines at angles $\theta = 10^\circ, 20^\circ, 30^\circ,$ and 40° to **MR**. The first line, at 10° to **MR**, is shown in Fig. 5.1. He repeats the procedure described in part (b), placing the mirror on each of the new lines in turn. The readings are shown in Table 5.1.

Table 5.1

$\theta/^\circ$	$\alpha/^\circ$
10	51
20	69
30	90
40	111
50	130

Plot a graph of $\alpha/^\circ$ (y -axis) against $\theta/^\circ$ (x -axis).

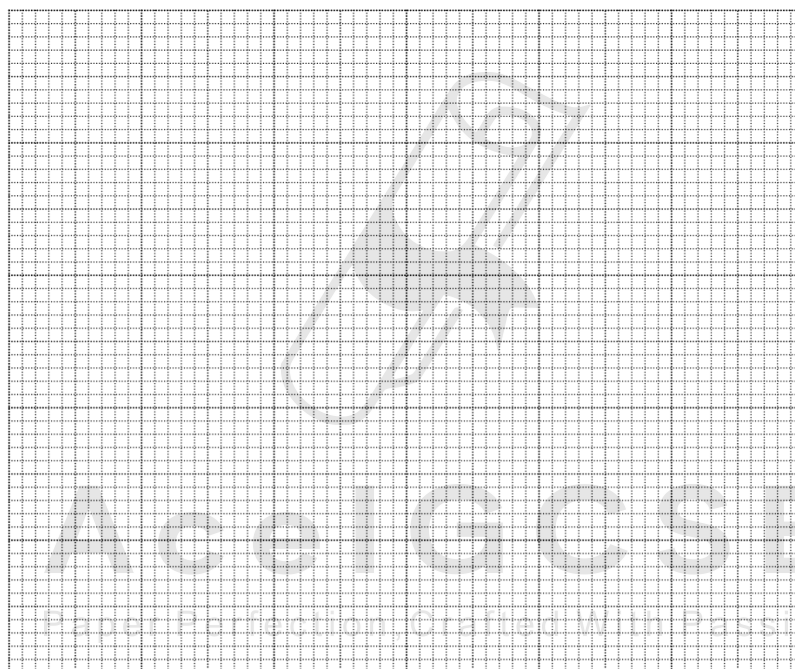

[5]

- (d) Determine the gradient G of the graph. Show clearly on the graph how you obtained the necessary information.

$G = \dots\dots\dots$ [2]

3.2. LIGHT

- (e) In this experiment, when the mirror is moved through an angle θ , the reflected ray moves through an angle $(\alpha - \alpha_0)$.

Table 5.2

$\theta/^\circ$	$\alpha/^\circ$	$(\alpha - \alpha_0)/^\circ$
10	51	
20	69	
30	90	
40	111	
50	130	

- (i) Complete Table 5.2.
- (ii) Suggest the relationship between $(\alpha - \alpha_0)$ and θ . You may express the relationship in words or as an equation.

.....
.....
[1]

- (f) State **one** precaution, to improve accuracy, which you would take in this experiment.

.....
.....[1]

[Total: 12]

38. 0625_s14_qp_62 Q: 4

An IGCSE student is determining the focal length of a lens.

Fig. 4.1 shows the apparatus.

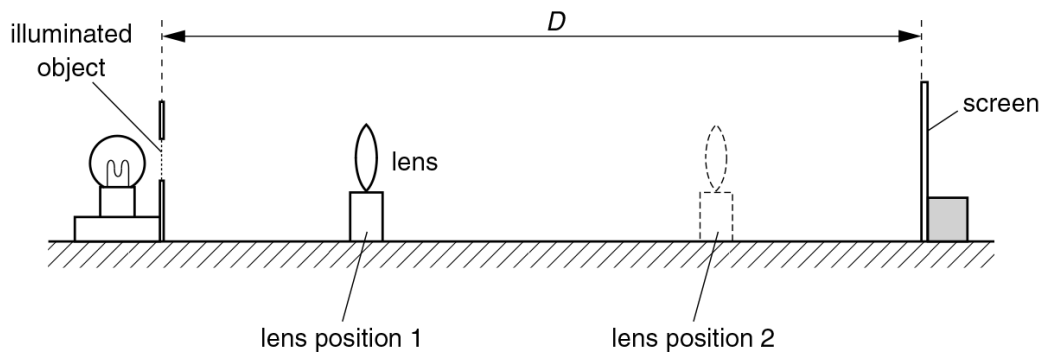

Fig. 4.1

- (a) The student places the screen at a distance $D = 80.0\text{cm}$ from the illuminated object. He places the lens close to the illuminated object. He moves the lens until a sharply-focused image of the object is seen on the screen (lens position 1).

He measures the distance x from the illuminated object to the centre of the lens.

$$x = \dots\dots\dots 19.5\text{cm}$$

He does not move the object or the screen, but moves the lens towards the screen until another sharply-focused image of the object is seen on the screen (lens position 2). He measures the distance y from the illuminated object to the centre of the lens.

$$y = \dots\dots\dots 60.4\text{cm}$$

- (i) On Fig. 4.1, carefully mark and label the distances x and y . [1]
- (ii) Calculate d using the equation $d = (y - x)$.

$$d = \dots\dots\dots$$

- (iii) Calculate d^2 .

$$d^2 = \dots\dots\dots$$

3.2. LIGHT

(iv) Calculate the focal length f of the lens, using the equation $f = \frac{D^2 - d^2}{4D}$.

$f =$ [2]

(b) State two precautions that you would take in this experiment to obtain reliable results.

- 1.
.....
 - 2.
.....
- [2]

(c) In the experiment, the student produces two images on the screen. They are both sharply focused.

(i) Suggest two differences between the two images.

- 1.
- 2.

(ii) Suggest one similarity between the two images.

.....
..... [3]

(d) Suggest a variable that could be changed when repeating this experiment to check the accuracy of the value obtained for the focal length f .

.....[1]

[Total: 9]

39. 0625_s14_qp_63 Q: 5

An IGCSE student is investigating shadows.

The apparatus she is using is shown in Fig. 5.1.

The object and the screen are square, with dimensions as shown in Fig. 5.1.

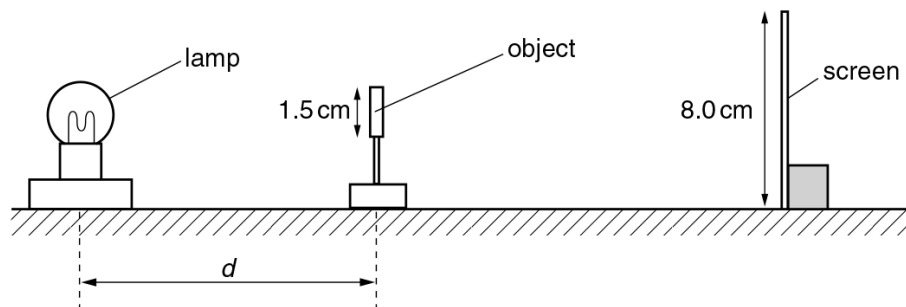

Fig. 5.1

She places the object at a distance d from the centre of the lamp so that it produces a shadow on the screen.

For various values of d , she measures the width w and height h of the shadow and records them in Table 5.1.

For each distance d , she calculates a value s , the average side length of the shadow, using her readings for w and h and the equation $s = \frac{w + h}{2}$.

(a) Fig. 5.2 shows the shadow produced on the screen when $d = 35$ cm. The shadow and screen are shown full size.

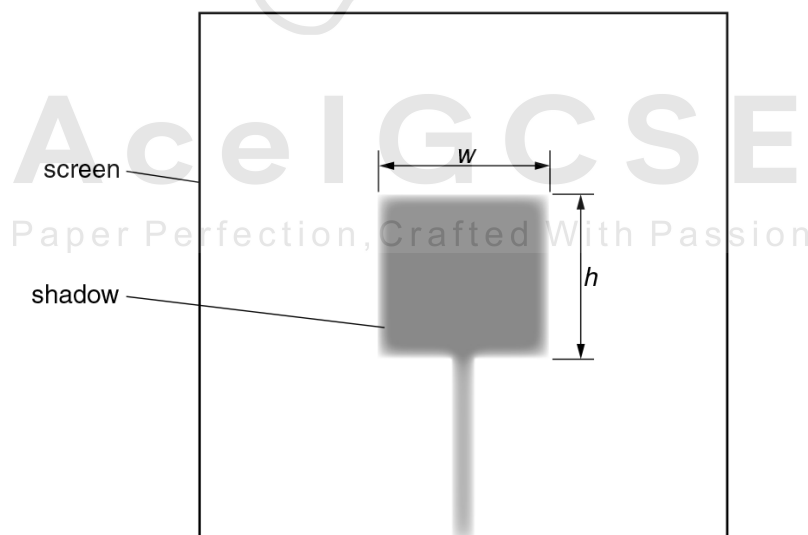

Fig. 5.2

3.2. LIGHT

- (i) Measure, and record in Table 5.1, the width w and the height h of the shadow.

Table 5.1

d/cm	w/cm	h/cm	s/cm
55	1.7	1.7	1.7
45	2.0	2.0	2.0
35			
25	3.8	3.9	3.9
20	4.4	4.6	4.5
15	5.8	6.2	6.0

[2]

- (ii) Calculate, and record in the table, the value of s when $d = 35$ cm.
- (iii) The object is square in shape. State a practical reason why it is useful to calculate s rather than just rely on w or h to show the size of the shadow.

.....
[1]

- (b) Plot a graph of s/cm (y -axis) against d/cm (x -axis).

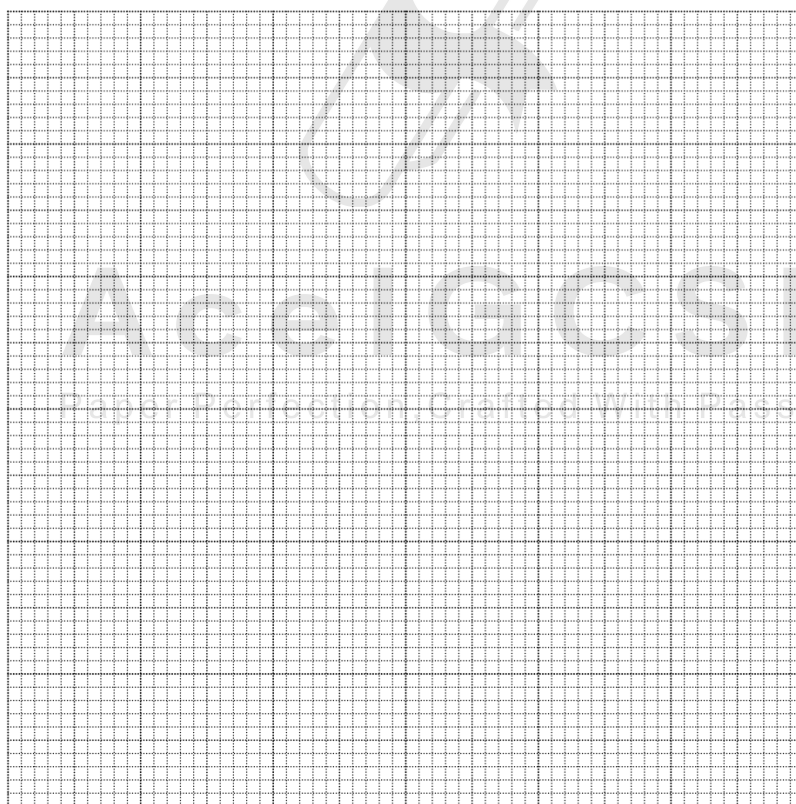

[5]

- (c) A value of $d = 20\text{cm}$ has been inserted between $d = 25\text{cm}$ and $d = 15\text{cm}$. This does not follow the pattern of the gaps of 10cm between the other distances.

Explain why it is useful to have this value when drawing the line on the graph.

.....
.....[1]

- (d) A student suggests that the distance between the lamp and the object in this experiment should be no less than 15cm .

From your observations of the readings and the apparatus being used, give a reason why this is a sensible suggestion.

.....
.....[1]

[Total: 10]



Ace | GCSE
Paper Perfection, Crafted With Passion

3.2. LIGHT

40.0625_w14_qp_61 Q: 1

The IGCSE class is investigating the reflection of light by a plane mirror. Fig. 1.1 shows a student's ray-trace sheet.

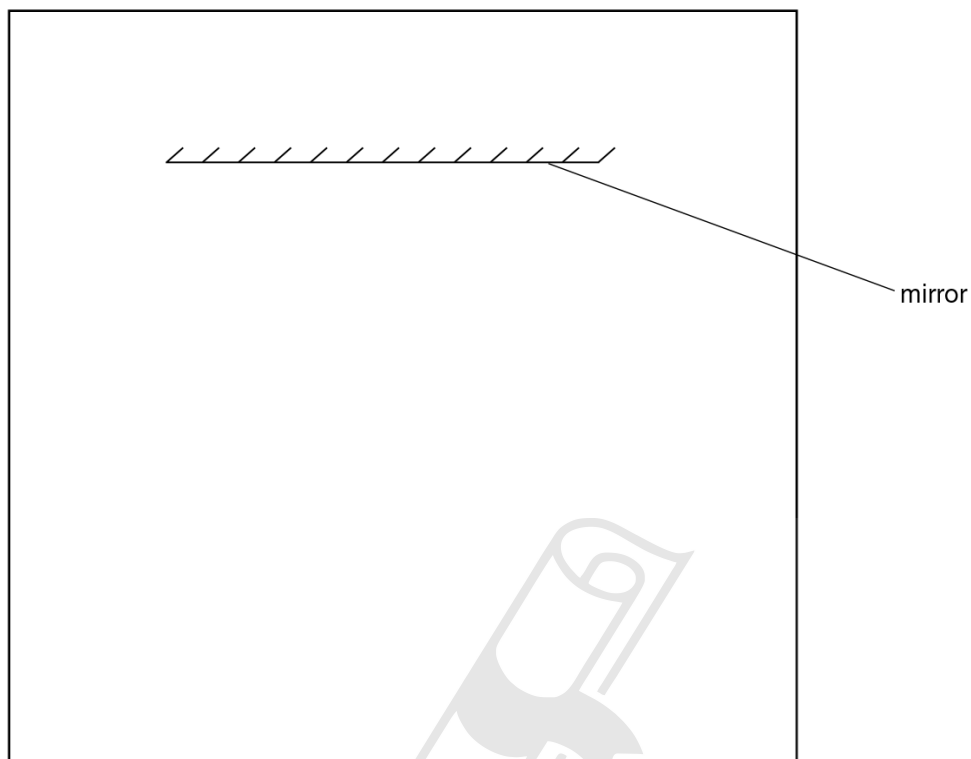

Fig. 1.1

- (a) On Fig. 1.1, draw a normal to the centre of the mirror. [1]
- (b) On Fig. 1.1, draw an incident ray at 30° to the normal and to the left of the normal. [1]
- (c) Fig. 1.2 shows a diagram of a ray box.

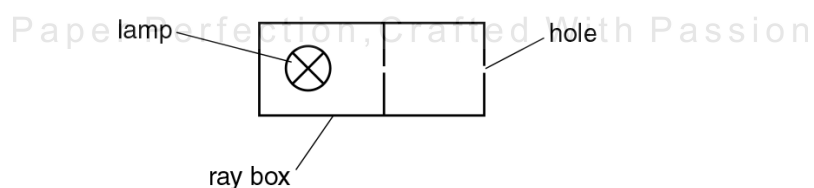

Fig. 1.2

On Fig. 1.1, draw the ray box in a suitable position to produce the incident ray that you have drawn. [1]

- (d) On Fig. 1.1, draw a reflected ray in the position you would expect it to be using the incident ray that you have drawn. [1]

(e) State two precautions that you could take in this experiment to obtain reliable results.

1.
.....

2.
.....

[2]

[Total: 6]



Ace | GCSE
Paper Perfection, Crafted With Passion

3.2. LIGHT

41. 0625_w14_qp_61 Q: 4

The IGCSE class is determining the magnification of an image produced by a lens.

The apparatus is shown in Fig. 4.1.

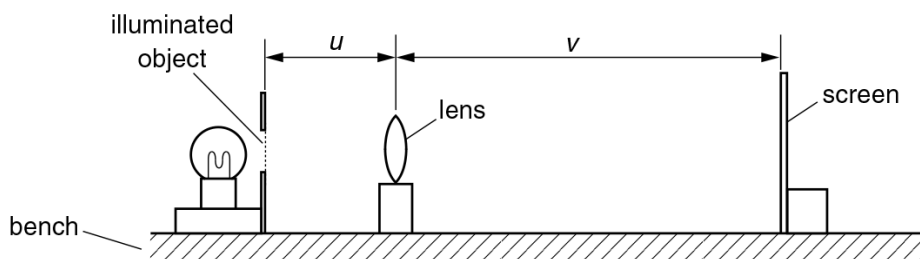

Fig. 4.1

- (a) (i) On Fig. 4.1, measure and record in mm the distance u from the illuminated object to the centre of the lens.

$u = \dots\dots\dots$ mm

- (ii) On Fig. 4.1, measure and record in mm the distance v from the centre of the lens to the screen.

$v = \dots\dots\dots$ mm
[1]

- (b) Calculate the ratio $\frac{v}{u}$.

$\frac{v}{u} = \dots\dots\dots$ [1]

- (c) The diagram is drawn one tenth of actual size.

- (i) Calculate the actual distance U from the illuminated object to the centre of the lens.

$U = \dots\dots\dots$ mm

- (ii) Calculate the actual distance V from the centre of the lens to the screen.

$V = \dots\dots\dots$ mm
[1]

- (d) The student measures the height h from the top to the bottom of the image on the screen.

$h = \dots\dots\dots 4.5 \dots\dots\dots$ cm

- (i) On Fig. 4.2, measure the height x of the illuminated object.

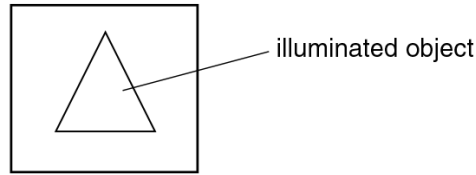

Fig. 4.2 (full size)

$x = \dots\dots\dots$

- (ii) Calculate $\frac{h}{x}$.

$\frac{h}{x} = \dots\dots\dots$ [1]

- (e) The magnification m of the image is given by the equation $m = \frac{h}{x}$. The student suggests that the ratio $\frac{V}{U}$ also gives the magnification m . State whether the results support this suggestion and justify your answer by reference to the results.

statement $\dots\dots\dots$

justification $\dots\dots\dots$

$\dots\dots\dots$ [2]

- (f) State two precautions that you could take in this experiment to obtain reliable results.

1. $\dots\dots\dots$

$\dots\dots\dots$

2. $\dots\dots\dots$

$\dots\dots\dots$ [2]

- (g) The image on the screen in this experiment is magnified and dimmer than the object.

State one other difference that you would expect to see between the image and the illuminated object.

$\dots\dots\dots$ [1]

- (h) Suggest one precaution that you would take in this experiment in order to focus the image as clearly as possible.

$\dots\dots\dots$

$\dots\dots\dots$ [1]

[Total: 10]

3.2. LIGHT

42. 0625_w14_qp_62 Q: 4

The IGCSE class is investigating refraction of light through a transparent block.

Fig. 4.1 shows a student's ray-trace sheet.

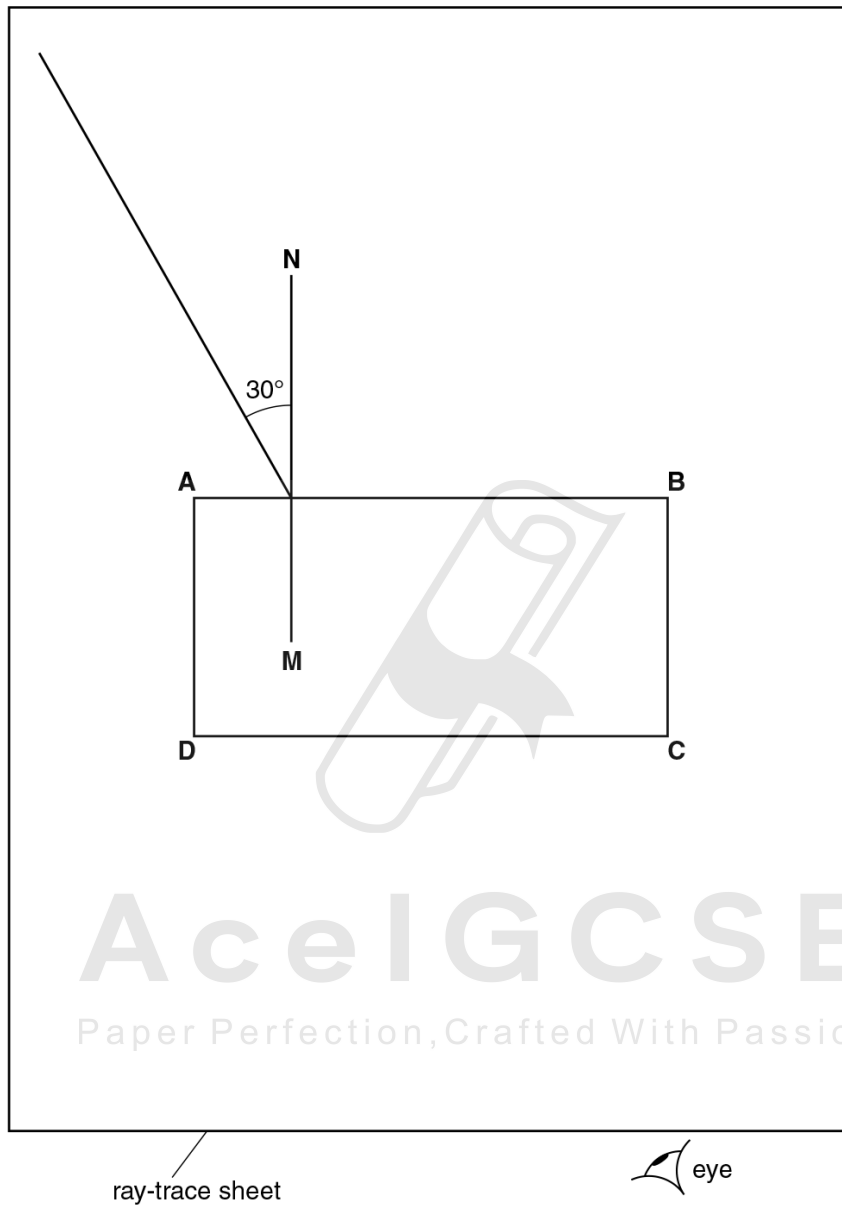

Fig. 4.1

- (a) (i) On Fig. 4.1, label the point **F** at which the incident ray crosses the normal **NM**. Label the other end of the ray **E**.
- (ii) On Fig. 4.1, draw a refracted ray from **F**, at an angle of refraction $r = 20^\circ$, to meet side **CD** of the block. Label the point **G** at which this ray meets side **CD** of the block. [1]

(b) Predict and draw on Fig. 4.1 the line of the ray that emerges from the block at point **G**. Label the end of your line **H**. [2]

(c) To obtain the correct positions for the emergent ray in this experiment, the student places two pins P_1 and P_2 on line **EF**. He observes the images of P_1 and P_2 through side **CD** of the block so that the images of P_1 and P_2 appear one behind the other.

He places two pins P_3 and P_4 between his eye and the block so that P_3 , P_4 and the images of P_1 and P_2 , seen through the block, appear one behind the other.

(i) On Fig. 4.1, mark the positions of the pins P_3 and P_4 at a suitable distance apart for this experiment. [1]

(ii) State two precautions that you should take in this experiment to obtain reliable results.

1.

 2.
 [2]

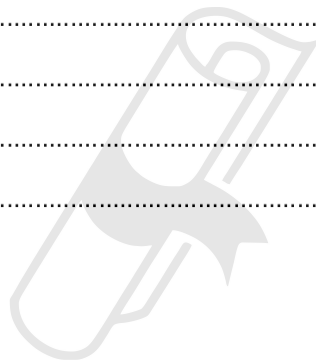

3.2. LIGHT

- (d) The student repeats the experiment with the block turned through 90° , as shown in Fig. 4.2. He measures the angle of refraction r .

$r = \dots\dots\dots 22^\circ \dots\dots\dots$

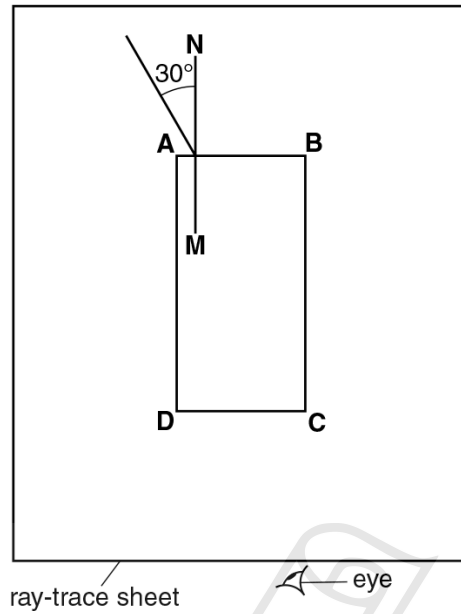

Fig. 4.2

He suggests that the value of r should be the same in both experiments because the material of the block has not changed.

State whether the results support this suggestion. Justify your answer by reference to the results.

statement

justification

AcelGCSE

Paper Perfection, Crafted With Passion

[1]

[Total: 7]

43. 0625_w14_qp_63 Q: 3

The IGCSE class is investigating the magnification produced by a converging lens.

The apparatus is set up as shown in Fig. 3.1.

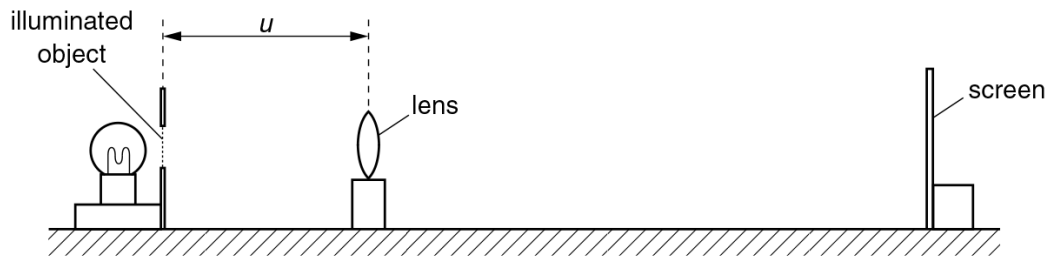

Fig. 3.1

(a) On Fig. 3.2, measure and record the height h_0 of the triangular object.

$h_0 = \dots\dots\dots$ cm [1]

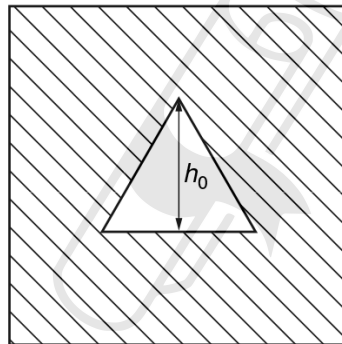

Fig. 3.2

Ace IGCSE
Paper Perfection, Crafted With Passion

3.2. LIGHT

- (b) The distance u between the illuminated object and the lens is set to 30.0 cm. The screen is moved until a sharp image of the illuminated object is seen, as shown in Fig. 3.3.

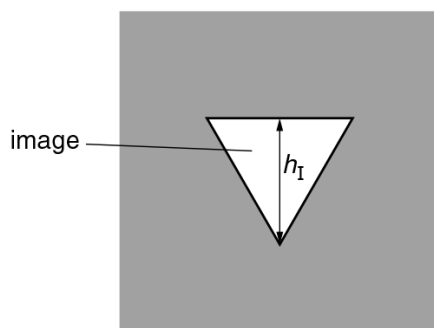

Fig. 3.3

Measure, and record in the first row of Table 3.1, the height h_I of the image.

Table 3.1

u/cm	h_I/cm	S
30.0		
35.0	1.5	
40.0	1.2	
45.0	1.0	
50.0	0.9	
55.0	0.8	

[2]

- (c) The process is repeated for u values of 35.0 cm, 40.0 cm, 45.0 cm, 50.0 cm and 55.0 cm. The h_I values obtained are shown in the table.

Complete Table 3.1 by calculating the values of S , using your result from (a) and the equation $S = \frac{h_0}{h_I}$.

(d) Plot a graph of S (y -axis) against u/cm (x -axis).

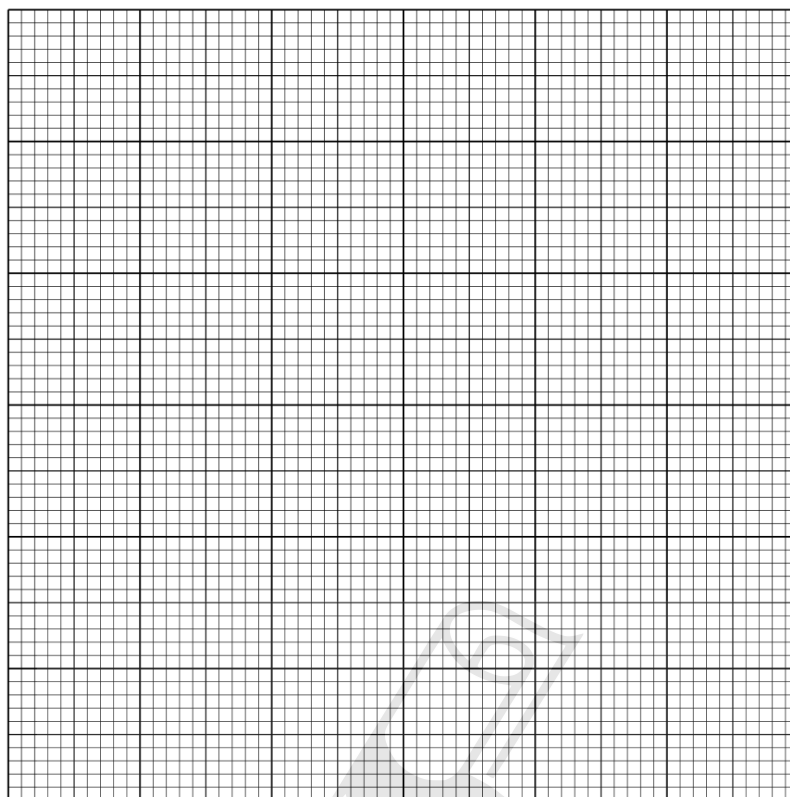

[5]

(e) (i) Determine the gradient G of the graph. Show clearly on the graph how you obtained the necessary information.

Ace | GCSE

$G = \dots\dots\dots$ [1]

(ii) Calculate the focal length f of the lens, where $f = \frac{1}{G}$ cm.

$f = \dots\dots\dots$ [1]

[Total: 10]

3.2. LIGHT

44. 0625_s13_qp_61 Q: 4

The IGCSE class is investigating the position of the image in a plane mirror.

A student's ray-trace sheet is shown in Fig. 4.1.

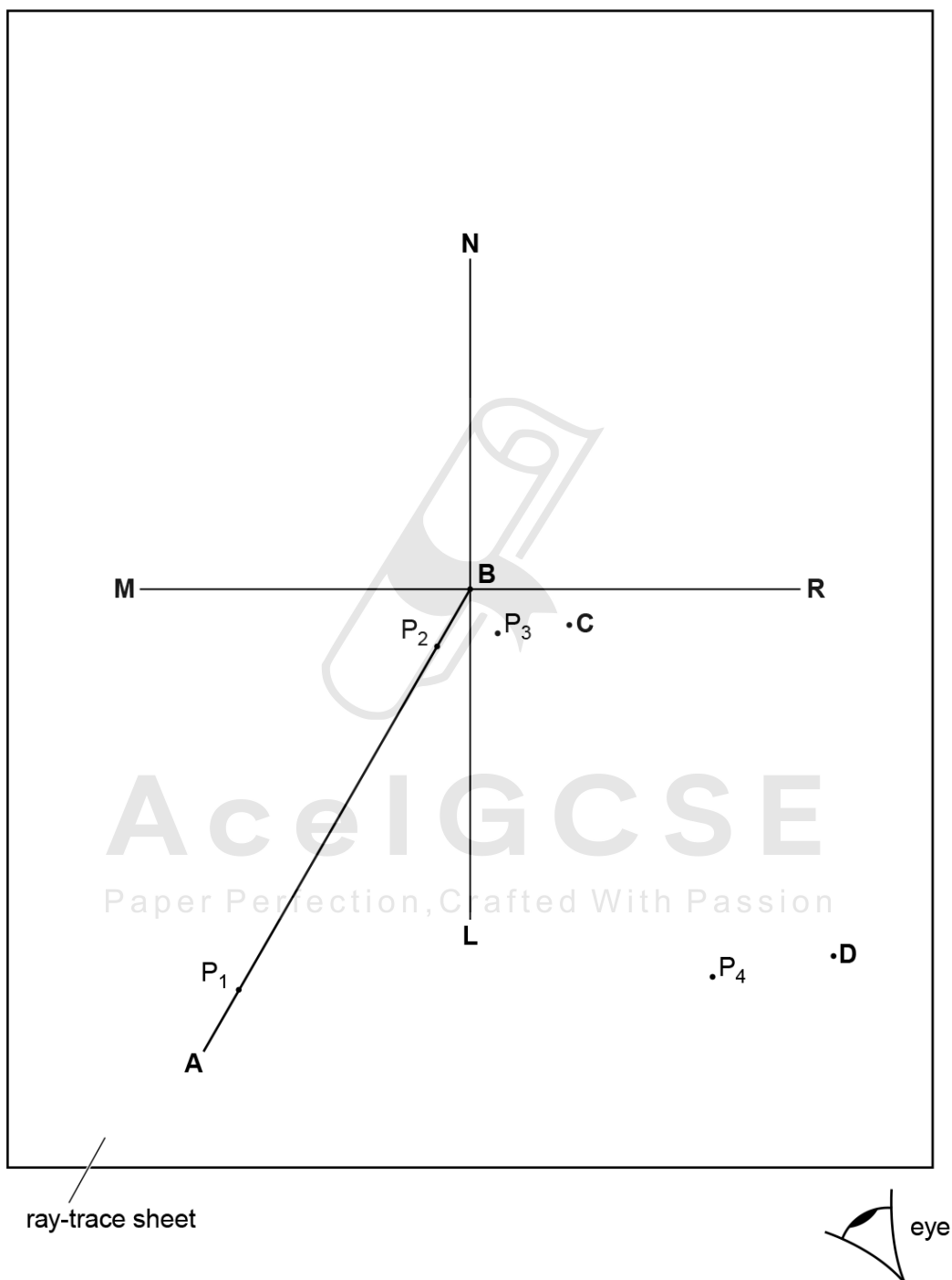

Fig. 4.1

The line **MR** shows the position of a plane mirror. **NL** is the normal at the centre of the mirror.

AB marks the position of an incident ray.

The student pushes two pins, P_1 and P_2 into this line. She views the images of pins P_1 and P_2 from the direction indicated by the eye in Fig. 4.1.

She places two pins P_3 and P_4 some distance apart so that pins P_4 and P_3 , and the images of P_2 and of P_1 , all appear exactly one behind the other. The positions of P_3 and P_4 are labelled.

(a) Draw in the line joining the positions of P_3 and P_4 . Continue the line until it crosses **MR** and extends at least 8.0 cm beyond **MR**. [1]

(b) The student repeats the procedure without moving pin P_1 but using a different angle of incidence. On Fig. 4.1, the new positions of pins P_3 and P_4 are marked **C** and **D**.

(i) Draw in the line joining the positions **C** and **D**. Continue the line until it extends at least 8.0 cm beyond **MR**.

(ii) Label with a **Y** the point where the two lines beyond **MR** cross. [1]

(c) (i) Draw a line from P_1 to **MR** that meets **MR** at a right angle. Measure and record the length a of this line.

$a = \dots\dots\dots$

(ii) Draw a line from the point labelled **Y** to **MR** that meets **MR** at a right angle. Measure and record the length b of this line.

$b = \dots\dots\dots$

[2]

(d) A student suggests that the length of a should equal the length of b .

State whether your results support this suggestion. Justify your statement by reference to your results.

statement

justification

.....

.....

[2]

(e) Suggest a precaution that you would take, when placing the pins, in order to obtain reliable results.

.....

..... [1]

[Total: 7]

3.2. LIGHT

45.0625_s13_qp_62 Q: 5

The IGCSE class is determining the focal length of a lens.

The apparatus is shown in Fig. 5.1.



Fig. 5.1

A student places the lens a distance $u = 25.0$ cm from an illuminated object of height 1.5 cm. She moves the screen until a sharply focused image of the object is seen on the screen.

She measures the height h of the image on the screen. She calculates $\frac{1}{h}$.

She repeats the procedure using a range of u values. Her results are shown in Table 5.1.

Table 5.1

u/cm	h/cm	$\frac{1}{h}/\frac{1}{\text{cm}}$
25.0	2.2	0.45
30.0	1.5	0.67
35.0	1.1	0.91
40.0	0.9	1.1
45.0	0.8	1.3

- (a) Plot a graph of u/cm (y -axis) against $\frac{1}{h}/\frac{1}{\text{cm}}$ (x -axis). You do not need to begin the axes at the origin (0,0).

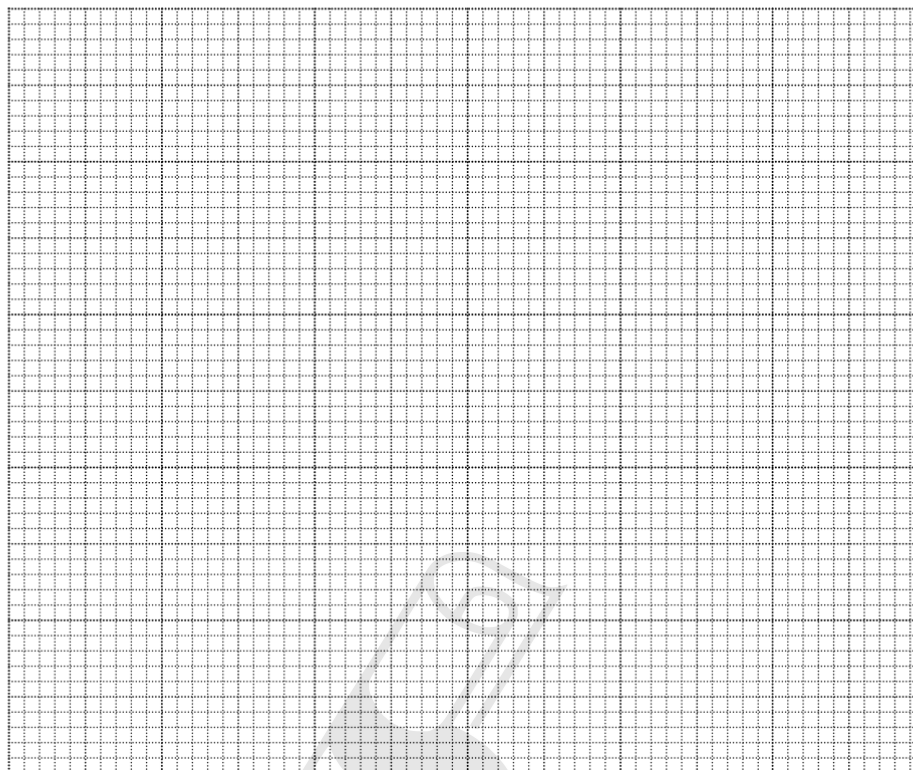

[5]

- (b) Determine the gradient G of the graph. Show clearly on the graph how you obtained the necessary information.

Paper Perfection, Crafted With Passion

$G = \dots\dots\dots$ [2]

- (c) Calculate the focal length f of the lens, using the equation $f = \frac{G}{1.5}$ cm. Give your answer to a suitable number of significant figures for this experiment.

$f = \dots\dots\dots$ [2]

3.2. LIGHT

(d) State two precautions that you would take in this experiment in order to obtain reliable results.

1.

.....

2.

.....

[2]

[Total: 11]



Ace | GCSE
Paper Perfection, Crafted With Passion

46. 0625_s13_qp_63 Q: 5

IGCSE students are investigating the magnification produced by a converging lens.

The apparatus is set up as shown below.

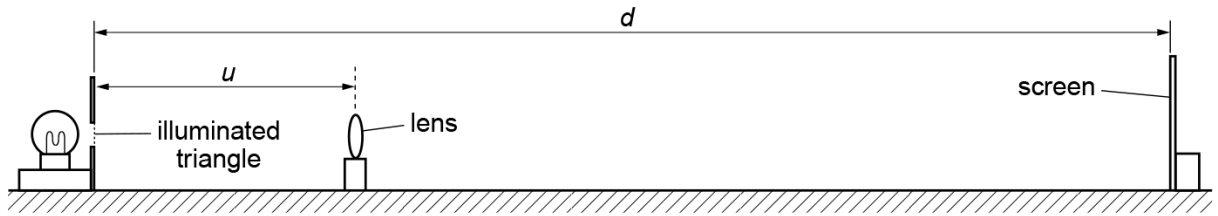

Fig. 5.1

The screen is moved until a sharp image of the object is seen on the screen.

- (a) (i) On Fig. 5.1, carefully measure u and record the value.

$u = \dots\dots\dots$

- (ii) On Fig. 5.1, carefully measure d , the distance between the illuminated triangle and the screen when the image is sharp, and record the value.

$d = \dots\dots\dots$

- (iii) Calculate a value m for the magnification, using your answers to (a)(i) and (a)(ii), and the equation $m = \frac{d-u}{u}$.

$m = \dots\dots\dots$

[2]

- (b) The illuminated triangle is shown in Fig. 5.2. The image of the triangle seen on the screen is shown in Fig. 5.3.

Paper Perfection, Crafted With Passion

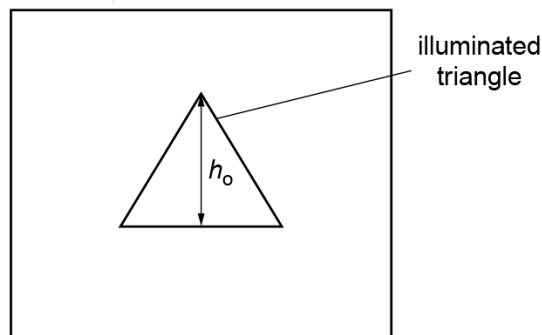

Fig. 5.2

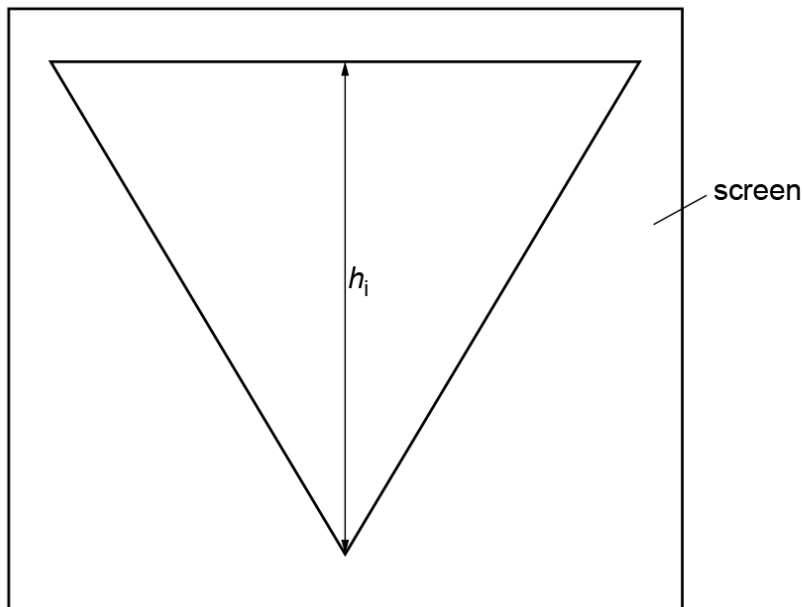

Fig. 5.3

- (i) Measure h_o , the height of the illuminated triangle, as shown in Fig. 5.2, and record the value.

$h_o =$

- (ii) Measure h_i , the height of the image on the screen, as shown in Fig. 5.3, and record the value.

$h_i =$

- (iii) Calculate M , another value for the magnification, using your answers to (b)(i) and (b)(ii), and the equation $M = \frac{h_i}{h_o}$.

$M =$

[2]

- (c) A student says that the values of m and M should be the same.

State whether your findings support this. Justify your answer by reference to your results for m and M .

statement

.....

justification

.....

.....

[2]

- (d) (i) Describe one difficulty the students might have found when measuring the height of the image on the screen.

Suggest a solution for the problem.

difficulty

.....

solution

.....

[2]

- (ii) Suggest one further precaution which should be taken to make the experiment reliable.

.....

.....

.....[1]

[Total: 9]

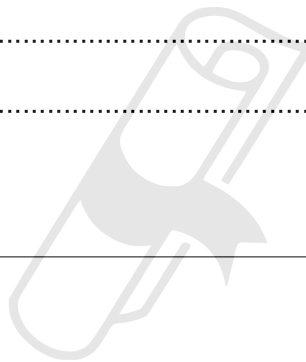

3.2. LIGHT

47.0625_w13_qp_61 Q: 4

The IGCSE class is determining the focal length of a converging lens.

Fig. 4.1 shows the apparatus used to produce an image on the screen.

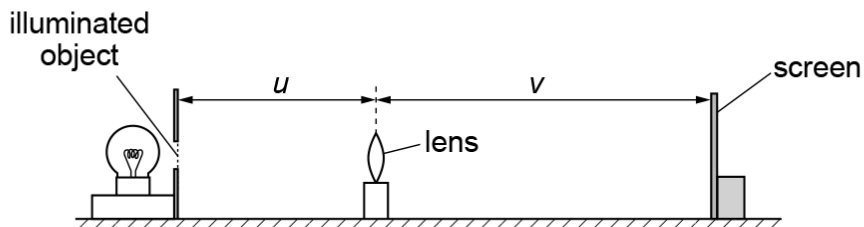

Fig. 4.1

- (a) (i) On Fig. 4.1, measure the distance u between the illuminated object and the centre of the lens.

$u =$

- (ii) On Fig. 4.1, measure the distance v between the centre of the lens and the screen.

$v =$

[2]

- (b) (i) Calculate uv .

$uv =$

- (ii) Calculate $u + v$.

$u + v =$

[1]

- (iii) Calculate x using the equation $x = \frac{uv}{(u + v)}$.

$x =$ [1]

- (c) Fig. 4.1 is drawn $1/10^{\text{th}}$ of actual size. The focal length f of the lens is given by the equation $f = 10x$.

Calculate a value for the focal length f of the lens, giving your answer to a suitable number of significant figures for this experiment.

$f =$ [2]

- (d) A student carrying out this experiment changes the position of the lens and then moves the screen to produce a well-focused image.

She records the distance v between the centre of the lens and the screen as $v = 18.2$ cm. She finds it difficult to decide the exact point at which the image is sharpest.

Suggest a range of v values for which the image may appear well-focused.

range of v values = to [1]

- (e) State two precautions that you could take in this experiment to obtain reliable results.

1.

.....

2.

.....

[2]

[Total: 9]

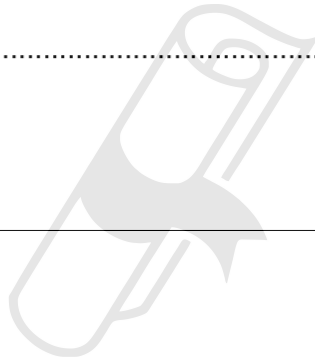

3.2. LIGHT

48. 0625_w13_qp_62 Q: 4

The IGCSE class is determining the focal length of a converging lens.

Fig. 4.1 shows the apparatus.

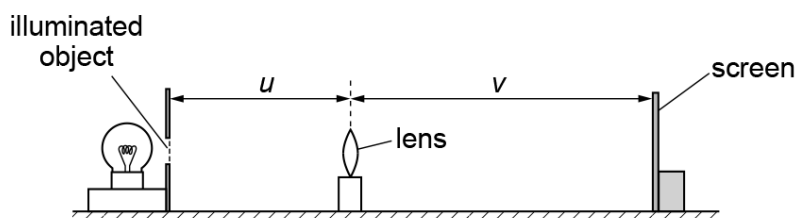

Fig. 4.1

- (a) (i) On Fig. 4.1, measure and record the distance u , in mm, between the illuminated object and the lens.

$u = \dots\dots\dots$ mm

- (ii) Measure and record the distance v , in mm, from the centre of the lens to the image on the screen.

$v = \dots\dots\dots$ mm
[1]

- (iii) Calculate the value of uv .

$uv = \dots\dots\dots$

- (iv) Calculate the value of $(u + v)$.

$(u + v) = \dots\dots\dots$

- (v) Calculate a value f_1 for the focal length of the lens, using the equation $f_1 = \frac{uv}{(u + v)}$.

$f_1 = \dots\dots\dots$
[2]

- (b) A student does not move the position of the screen or the illuminated object. She moves the lens towards the screen until a smaller, sharply focused image of the object is seen on the screen.

The new values of u and v are

$u = \dots\dots\dots 42 \text{ mm}$

$v = \dots\dots\dots 25 \text{ mm}$

- (i) Calculate the value of uv .

$uv = \dots\dots\dots$

- (ii) Calculate the value of $(u + v)$.

$(u + v) = \dots\dots\dots$

- (iii) Calculate a second value f_2 for the focal length of the lens, using the equation

$$f_2 = \frac{uv}{(u + v)}$$

$$f_2 = \dots\dots\dots [1]$$

- (c) A student suggests that f_1 should be equal to f_2 .

State whether the results support this suggestion. Justify your answer by reference to the results.

statement

justification

..... [2]

- (d) State two precautions that you could take in this experiment to obtain reliable results.

1.

.....

2.

..... [2]

- (e) The illuminated object is triangular, as shown in Fig. 4.2.

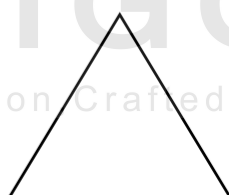
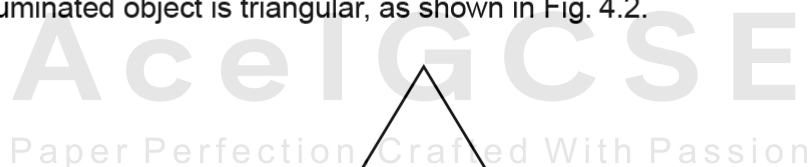

Fig. 4.2

Sketch the image you would see on the screen.

[1]

[Total: 9]

3.2. LIGHT

49.0625_w13_qp_63 Q: 4

An IGCSE class is investigating the reflection of light by a plane mirror.

One student's ray-trace sheet is shown in Fig. 4.1.

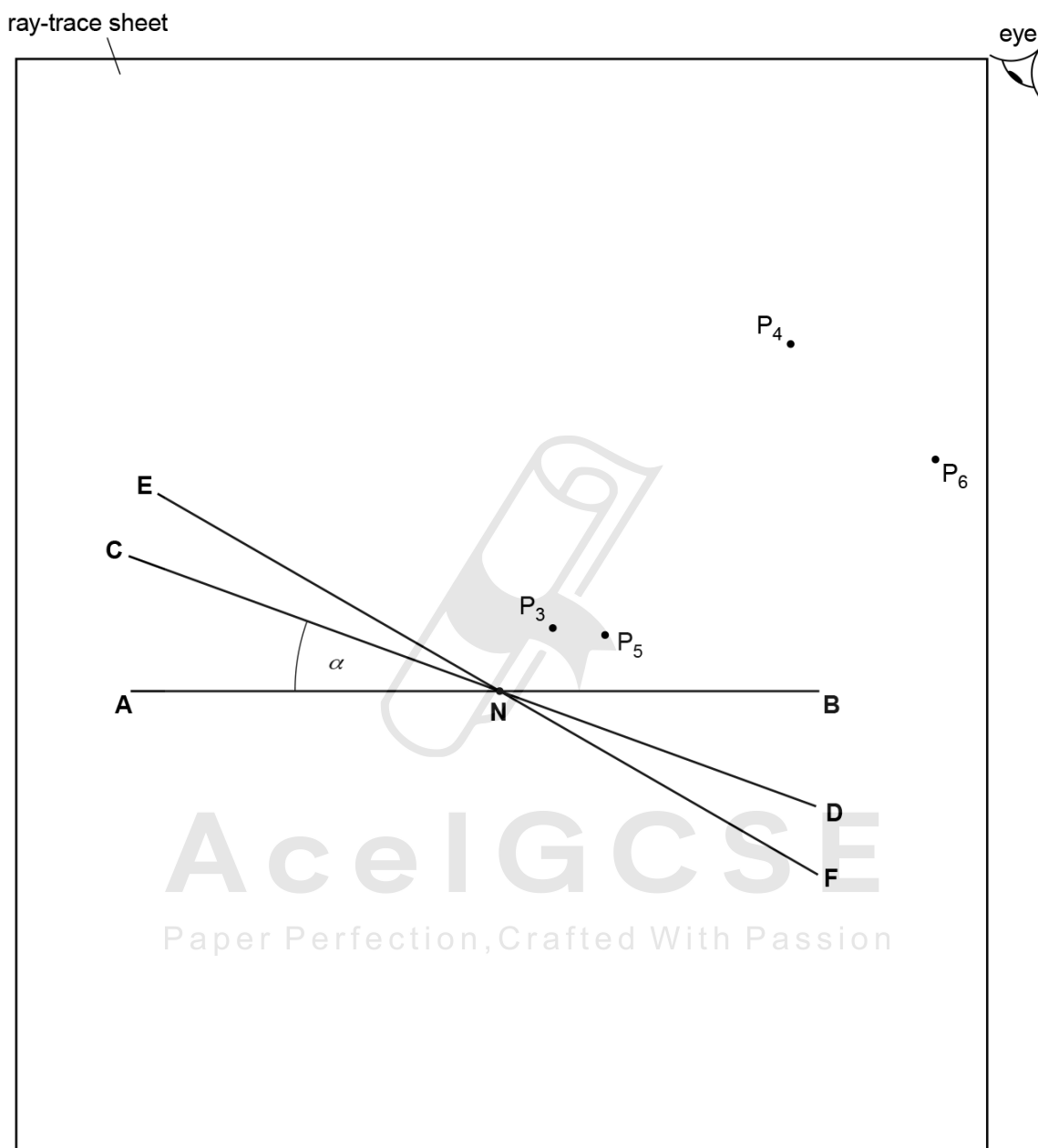

Fig. 4.1

- (a) In the first part of the experiment, a plane mirror is to be placed on line **CD**.
- Draw a normal to **AB** at point **N**, towards the top of the page. Label the other end of this normal **L**.
 - Two pins P_1 and P_2 are placed on line **LN**. Label suitable positions for P_1 and P_2 .
- [1]

- (b) The mirror is placed on line **CD** and the images of P_1 and P_2 are viewed from the direction indicated by the eye in Fig. 4.1.

Two pins P_3 and P_4 are placed so that the images of P_1 and P_2 , and the pin P_3 all appear exactly in line with P_4 .

- (i) Draw a line passing through P_3 and P_4 and reaching **AB**.
 (ii) Measure the angle θ between this line and the normal **NL**. Record this value in Table 4.1. [1]

- (c) The mirror is then moved to line **EF** and pins P_5 and P_6 are placed in line with the new images.

Repeat steps (b)(i) and (b)(ii) using the new mirror line and pin positions. [1]

Table 4.1

	$\alpha/^\circ$	$\theta/^\circ$
mirror on CD	20	
mirror on EF	30	

[1]

- (d) A student suggests that θ should always be equal to 2α .

State whether the experimental results support this idea. Justify your answer with reference to the results.

statement

 justification

[2]

- (e) Suggest two precautions that could be taken to ensure accurate results from this experiment.

1.

 2.

[2]

[Total: 8]

3.2. LIGHT

50.0625_s12_qp_61 Q: 4

The IGCSE class is determining the focal length of a lens.

The apparatus is shown in Fig. 4.1.

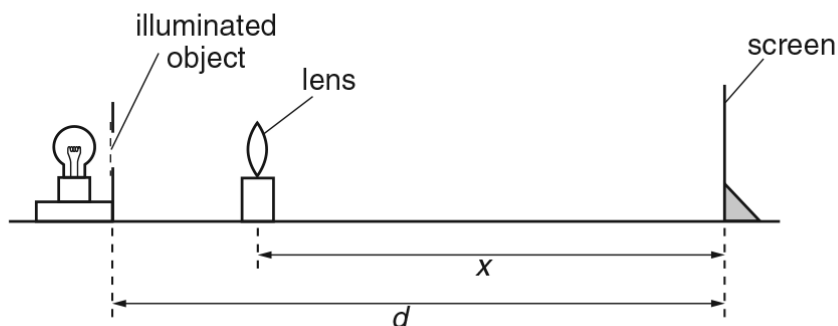

Fig. 4.1

(a) A student places the lens between the object and the screen and close to the object. She moves the lens towards the screen until a clearly focused, **enlarged** image is formed on the screen.

(i) On Fig. 4.1, measure and record the distance d between the object and the screen.

$d =$

(ii) On Fig. 4.1, measure and record the distance x between the centre of the lens and the screen.

$x =$

[2]

(iii) Fig. 4.1 is drawn one tenth actual size.

1. Calculate the actual distance D between the object and the screen.

$D =$

2. Calculate the actual distance X between the centre of the lens and the screen.

$X =$

[1]

(b) Without moving the illuminated object or the screen, the student moves the lens towards the screen until a clearly focused, **diminished** image is formed on the screen. She measures the distance Y between the centre of the lens and the screen: $Y = 19.0\text{ cm}$.

Calculate the focal length f of the lens using the equation $f = \frac{XY}{D}$.

- (c) The student turns the lens through an angle of 180° and repeats the procedure obtaining a value for the focal length $f = 14.7$ cm.

Theory suggests that the two values of the focal length f should be the same. State whether the results support this theory and justify your answer by reference to the results.

statement

justification

..... [2]

- (d) Briefly describe a precaution that you would take in this experiment in order to obtain a reliable result.

.....
.....
..... [1]

[Total: 8]



3.2. LIGHT

51.0625_s12_qp_62 Q: 4

A student is measuring some small glass spheres.

(a) The student has a 30cm rule and two rectangular blocks of wood.

In the space below, draw a diagram to show clearly how you would arrange the apparatus to measure the diameter of **one** of the spheres.

[2]



Ace | GCSE
Paper Perfection, Crafted With Passion

- (b) The student then determines the average volume of a glass sphere by a displacement method. She pours some cold water into a measuring cylinder and records the volume V of the water, as shown in Fig. 4.1.

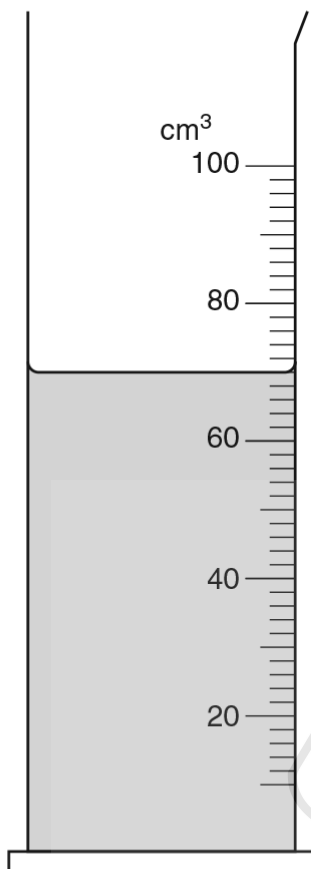

Fig. 4.1

- (i) On Fig. 4.1, show clearly the line of sight that you would use to obtain an accurate volume reading. [2]
- (ii) Using Fig. 4.1, record the volume V of water in the measuring cylinder.

$$V = \dots\dots\dots [1]$$

- (iii) The student carefully puts 15 of the glass spheres into the measuring cylinder. The new water level reading is 78cm^3 .

Calculate the volume V_1 of **one** sphere.

$$V_1 = \dots\dots\dots [1]$$

[Total: 6]

3.2. LIGHT

52. 0625_s12_qp_63 Q: 5

The IGCSE class is determining the refractive index of the material of a transparent block.

Fig. 5.1 shows a student's ray-trace sheet.

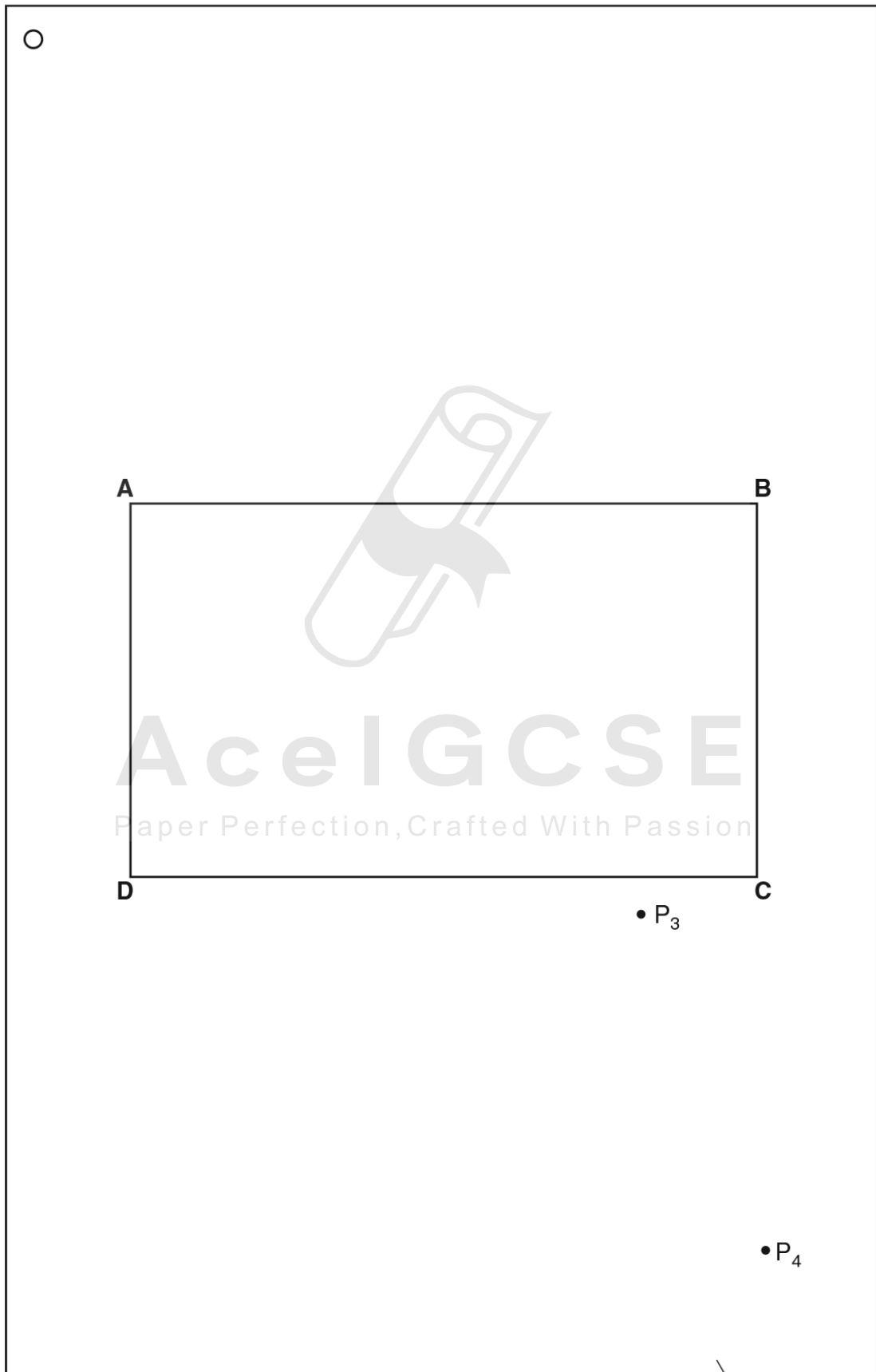

ray-trace sheet

- (a) **ABCD** is a transparent block placed, largest face down, on the ray-trace sheet.
- (i) On Fig. 5.1, draw a normal at the centre of side **AB**. Label the point **E** where the normal crosses **AB**. Mark a point **N** on the normal 4.0 cm from **E** and outside the outline of the block. [1]
- (ii) Draw a line **NF** from **N** to the block. This line must be to the right of the normal and at an angle of 20° to the normal. Mark the point **F** where the line meets **AB**. Measure and record the length a of the line **NF**.

$$a = \dots\dots\dots [2]$$

- (b) The student places two pins P_1 and P_2 on the line through **F** and **N**. She observes the images of P_1 and P_2 through side **CD** of the block so that the images of P_1 and P_2 appear one behind the other.

She places two pins P_3 and P_4 between her eye and the block so that P_3 and P_4 and the images of P_1 and P_2 , seen through the block, appear one behind the other. The positions of P_3 and P_4 are marked on Fig. 5.1.

- (i) Draw a line joining the positions of P_3 and P_4 . Continue the line until it meets **CD**. Label this point **G**.
- (ii) Draw the line **GF** and continue it until it meets the normal. Label this point **H**.
- (iii) Measure and record the length b of the line **FH**.

$$b = \dots\dots\dots [3]$$

- (iv) Calculate the refractive index n of the material of the block, using the equation $n = \frac{b}{a}$.

$$n = \dots\dots\dots [2]$$

- (c) Suggest one precaution that you would take in this experiment to obtain readings that are as accurate as possible.

.....
 [1]

[Total: 9]

3.2. LIGHT

53. 0625_w12_qp_61 Q: 4

The IGCSE class is investigating the refraction of light passing through a transparent block.

The apparatus and ray-trace sheet are shown in Fig. 4.1.

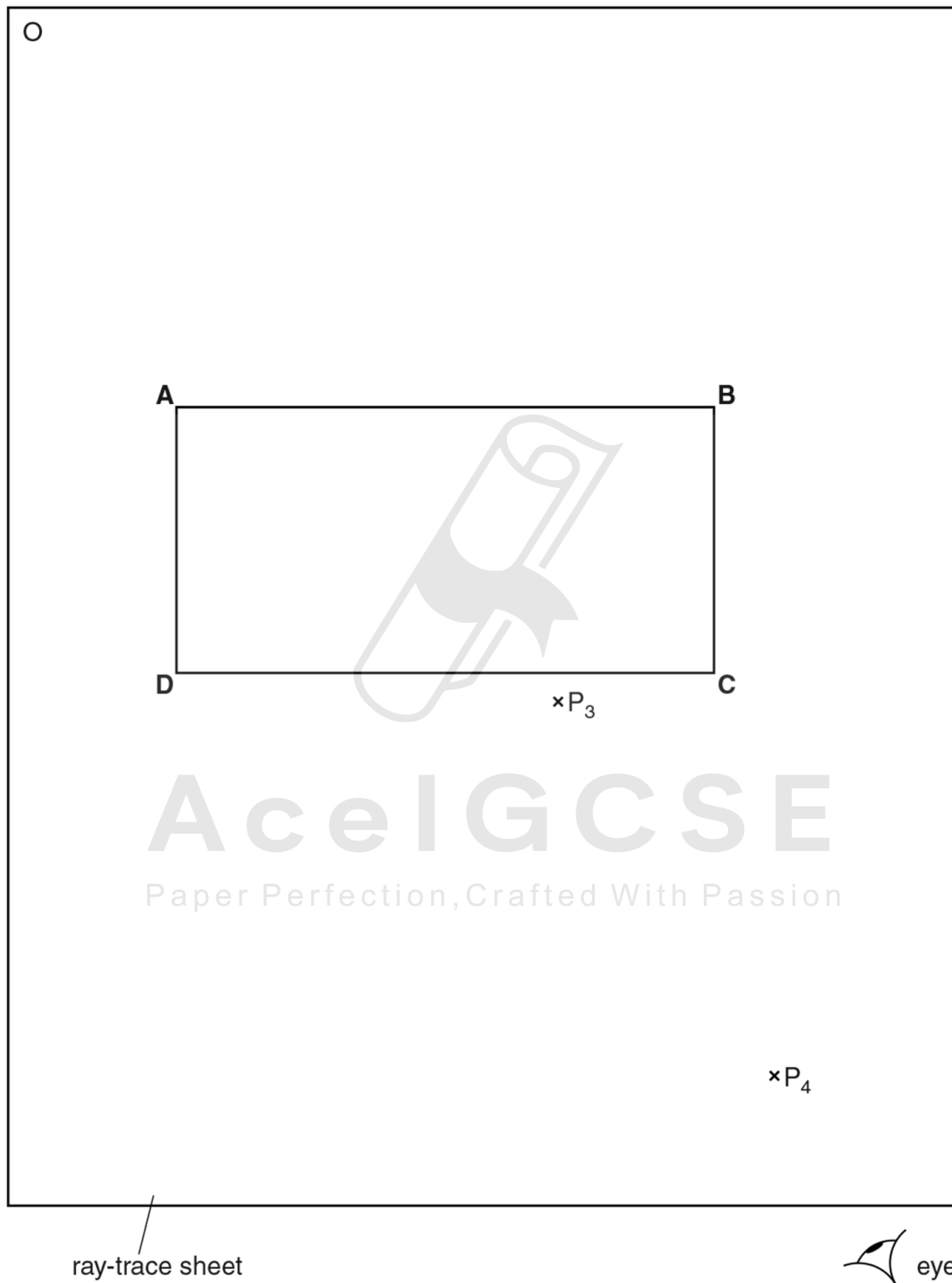

Fig. 4.1

(a) A student places the transparent block, largest face down, on the ray-trace sheet. She draws the outline of the block **ABCD**.

(i) On Fig. 4.1, draw a normal at the centre of side **AB**. Label the point **E** where the normal crosses **AB**.

(ii) Draw a line **FE** to the left of the normal and at an angle of incidence $i = 30^\circ$ to the normal. [2]

(b) The student places two pins P_1 and P_2 on the line **FE**, placing one pin close to **E**. She observes the images of P_1 and P_2 through side **CD** of the block so that the images of P_1 and P_2 appear one behind the other. She places two pins P_3 and P_4 between her eye and the block so that P_3 and P_4 , and the images of P_1 and P_2 seen through the block, appear one behind the other.

(i) On Fig. 4.1, mark suitable positions for the pins P_1 and P_2 . [1]

(ii) Draw a line joining the positions of P_3 and P_4 . Continue the line until it meets **CD** and label this point **G**.

(iii) Draw the line **GE**. [1]

(c) (i) Measure and record the angle of refraction r between the line **GE** and the normal.

$r = \dots\dots\dots$ [1]

(ii) Calculate the ratio $\frac{i}{r}$.

$\frac{i}{r} = \dots\dots\dots$ [1]

(d) The student repeats the procedure but with the angle of incidence $i = 40^\circ$. The angle of refraction $r = 26^\circ$.

(i) Calculate the ratio $\frac{i}{r}$.

$\frac{i}{r} = \dots\dots\dots$ [1]

(ii) A student suggests that the ratio $\frac{i}{r}$ should be a constant.

State and explain briefly whether your results support this suggestion.

.....

 [1]

[Total: 8]

3.2. LIGHT

54. 0625_w12_qp_62 Q: 1

The IGCSE class is carrying out refraction experiments using a rectangular glass block and optical pins.

- (a) In the middle of the space below, draw a line, 10cm long, across the page and label it **AB**. This line represents one side of the glass block.



AcelIGCSE
Paper Perfection, Crafted With Passion

- (b) Draw a normal to this line at the centre of **AB**. [1]
- (c) Draw a line at 30° to the normal to represent an incident ray. This line should be at least 6 cm long. Label this line **EF**. [1]
- (d) Mark the positions of two pins P_1 and P_2 on line **EF**. They should be positioned at suitable places on the line in order carry out a ray-tracing experiment as accurately as possible. [1]

- (e) A student finds that his completed results from the refraction experiment do not quite match the theory. The student carried out the experiment correctly and with reasonable care.

Suggest a practical reason why the results could differ slightly from the results expected from the theory.

.....
.....
.....[1]

[Total: 5]



Ace | GCSE
Paper Perfection, Crafted With Passion

3.2. LIGHT

55.0625_w12_qp_62 Q: 4

The IGCSE class is determining the focal length of a lens.

The apparatus is shown in Fig. 4.1.

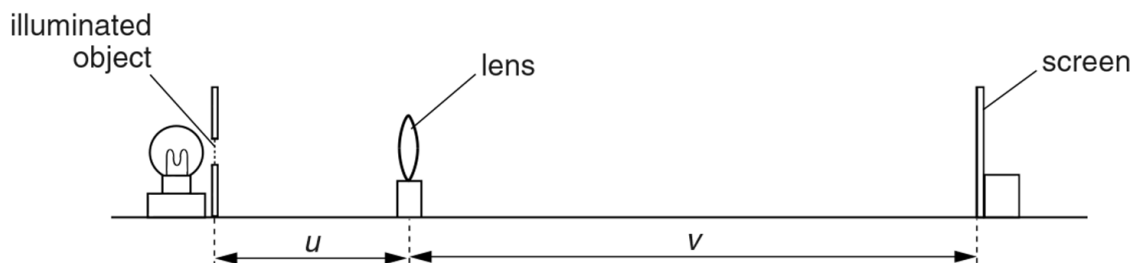

Fig. 4.1

A student places a lens at a distance $u = 30.0\text{ cm}$ from an illuminated object. She moves the screen until a sharply focused image of the object is seen on the screen.

She measures the distance v between the centre of the lens and the screen. She calculates d , using the equation $d = u + v$.

She repeats the procedure using a range of values of u . The values of u , v and d are shown in Table 4.1.

Table 4.1

u/cm	v/cm	$uv/$	$d/$
30.0	29.8		59.8
45.0	22.0		67.0
50.0	21.8		71.8
55.0	21.0		76.0
60.0	19.9		79.9

- (a) (i) Calculate the value of uv for each set of readings and enter the values in the table.
 (ii) Complete the column headings in the table by inserting the units for uv and d .

[2]

- (b) Complete the labelling of the axes below, and plot the graph using data from the table. You do **not** need to begin the axes at the origin (0,0).

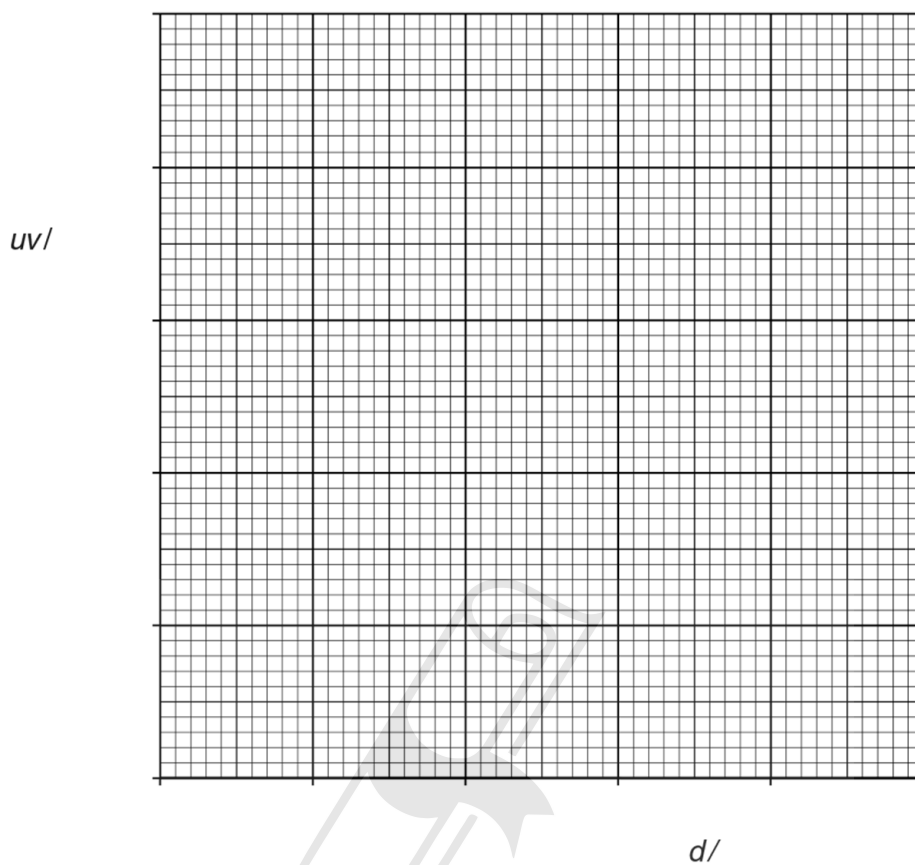

[4]

- (c) The gradient of the graph is numerically equal to the focal length of the lens.
- (i) Determine the gradient G of the graph. Show clearly on the graph how you obtained the necessary information.

$$G = \dots\dots\dots [2]$$

- (ii) State a value for the focal length f of the lens, giving your answer to a suitable number of significant figures for this experiment.

$$f = \dots\dots\dots [2]$$

[Total: 10]

3.2. LIGHT

56.0625_w12_qp_63 Q: 4

An IGCSE class is carrying out an experiment to determine the focal length of a converging lens.

The apparatus is set up as shown in Fig. 4.1.

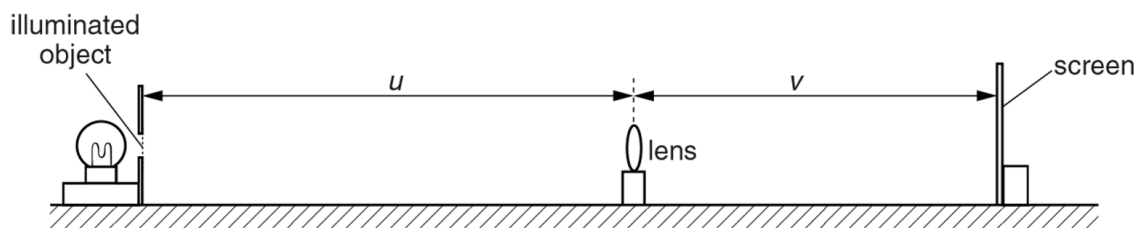

Fig. 4.1

(a) The object distance u is set and a sharp image is obtained on the screen.

(i) Measure the object distance u on Fig. 4.1.

$u = \dots\dots\dots$

(ii) Measure the image distance v on Fig. 4.1.

$v = \dots\dots\dots$

[1]

(iii) The diagram is drawn to $\frac{1}{5}$ th full size. Determine the actual values, in metres, of u and v . Record these values in Table 4.1.

(b) Four more object distances are set up and these and the corresponding image distances are recorded in Table 4.1.

Complete the table by calculating values of $\frac{1}{u}$ and $\frac{1}{v}$ as necessary.

Paper Perfection, Crafted With Passion

Table 4.1

u / m	$\frac{1}{u} / \frac{1}{\text{m}}$	v / m	$\frac{1}{v} / \frac{1}{\text{m}}$
0.200	5.00	0.600	
0.250	4.00	0.392	
0.450	2.22	0.222	
0.600	1.67	0.196	

[2]

- (c) Plot a graph of $\frac{1}{v} / \frac{1}{m}$ (y-axis) against $\frac{1}{u} / \frac{1}{m}$ (x-axis). Begin both axes at the origin (0,0). The scale must allow the best-fit line, when extended beyond the range of the data, to cross both axes.

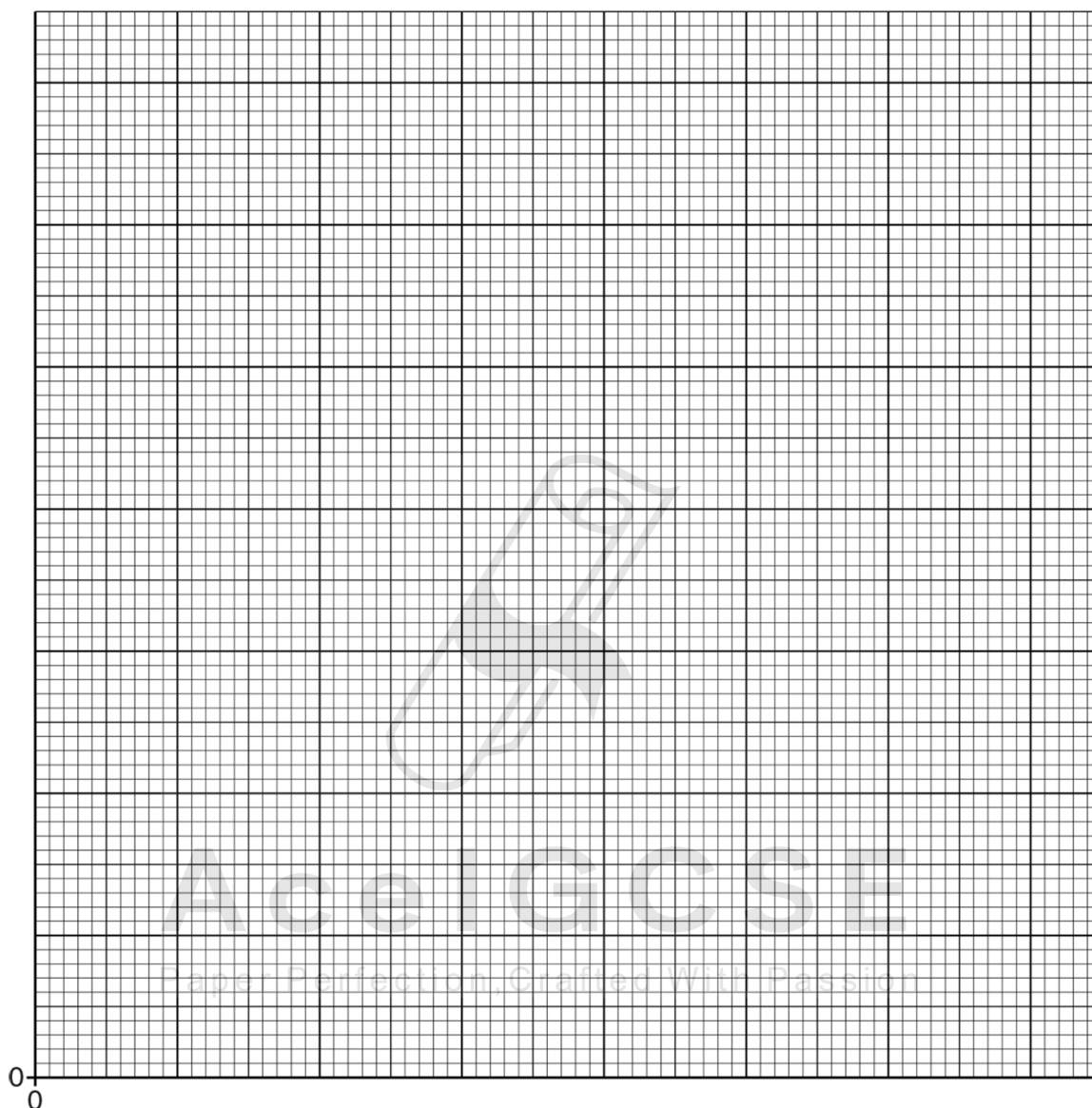

[4]

- (d) (i) From the graph, determine the value p of $\frac{1}{u}$ when $\frac{1}{v}$ is zero (the x-intercept).

$p = \dots\dots\dots$

- (ii) From the graph, determine the value q of $\frac{1}{v}$ when $\frac{1}{u}$ is zero (the y-intercept).

$q = \dots\dots\dots$ [1]

- (e) (i) Calculate z , where z is the average value of p and q .

$$z = \dots\dots\dots$$

- (ii) Calculate the focal length f of the lens where $f = \frac{1}{z}$.

$$f = \dots\dots\dots$$

[2]

[Total: 10]



Ace | GCSE
Paper Perfection, Crafted With Passion

01. 0625_s20_MS_61 Q: 3

(a)(i)	P_2 at least 5.0 cm from P_1	1
(a)(ii)	Straight line joining pin positions	1
	Extended at least 7 cm behind mirror	1
(b)(i)	Correct line and correct position of Y labelled	1
(b)(iii)	Correct a to within ± 2 mm	1
(b)(iii)	Correct b to within ± 2 mm	1
(c)(i)	Correct x measured and correct unit seen at a , b or x and not contradicted	1
(c)(ii)	Diagram to show image in mirror meeting top of pin above mirror	1
(d)	Statement to match results	1
	Justification to match statement with correct reference to results	1
(e)	Any one from: Thickness to mirror Thickness of lines Difficulty in judging exact lining up of pins.	1

02. 0625_s20_MS_63 Q: 3

(a)(i)	$u = 4.0$ (cm) <u>and</u> $v = 8.6$ (cm)	1
(a)(ii)	$U = 20.0$ (cm) <u>and</u> $V = 43.0$ (cm)	1
(a)(iii)	$f_1 = 13.7$ <u>and</u> unit	1
(a)(iv)	move screen backwards and forwards / slowly	1
(b)(i)	$v = 3.5$ (cm) <u>and</u> $V = 17.5$ (cm)	1
(b)(ii)	$h_o = 2.0$ (cm) <u>and</u> $h_i = 0.8$ (cm)	1
(b)(iii)	$M = 0.4$ <u>and</u> no unit	1
(b)(iv)	$f_2 = 12.5$ (cm)	1
(c)	any one from: mark position of lens on holder clamp rule / place rule on bench ensure screen, lens and object all perpendicular view scale perpendicularly	1
(d)(i)	difficult to measure height of image (accurately) as image is small	1
(d)(ii)	use larger object / graph paper on screen OR mark top and bottom of image and measure later	1

03. 0625_m19_MS_62 Q: 1

(a)(i)	$\theta = 23(^{\circ}) \pm 1^{\circ}$	1
(a)(ii)	normal correct	1
(b)	not at a suitable distance and should be far (as possible) from N	1
(c)	all lines present, neat and labelled correctly	1
	$a = 10.2 \text{ (cm)} \pm 0.1 \text{ (cm)}$	1
(d)	graph: • axes labelled with quantity and unit	1
	• appropriate scales (plots occupying at least $\frac{1}{2}$ grid)	1
	• plots all correct to $\frac{1}{2}$ small square, precise plots	1
	• well judged line and thin continuous line	1
(e)	any suitable reason e.g.: ray has finite thickness – (difficult to mark position of ray precisely), reflecting surface of mirror at rear, inaccuracies have more effect for smaller angles, small variations in mirror angle have significant effect on 'a'	1
(f)	reflect ray below NL at same angles and take averages	1

04. 0625_s19_MS_62 Q: 4

	Apparatus	1
	MP1 diagram showing object, lens, screen/image in correct order	
	MP2 u and v correctly labelled on diagram	1
	Method	1
	MP3 measure/record/calculate u and v and lens thickness t	
	MP4 repeat with a different lens	1
	MP5 method of obtaining a sharp image by moving object, lens or screen....	1
	Measuring lens thickness	1
	MP6 use of blocks either side of lens (and measure distance)	
	Table	1
	MP7 table with columns for u , v and t with correct units	

05. 0625_w19_MS_62 Q: 3

(a)(i)	$d = 8.0 \text{ cm}$ or 80 mm	1
(a)(ii)	$D = 80 \text{ cm}$ or 800 mm	1
(b)	$15.2 / 15.25 / 15.249 \text{ (cm)}$	1
(c)(i)	$14.9 / 14.85 \text{ (cm)}$	1
(c)(ii)	correct average	1
	3 significant figures only	1
(d)	one from: darkened room / brighter lamp object and lens at same height (above bench) object and lens and screen perpendicular to the bench ruler on bench or clamped mark centre of lens (on holder) move lens slowly / back and forth (to obtain best image)	1
(e)(i)	$D = 120.0 \text{ (cm)}$	1
(e)(ii)	$(22.2 \square 97.9) / 120$ $= 18.1 \text{ (cm)}$	1
(e)(iii)	(expect not in agreement) too far apart / not close enough / more than 10% difference between values	1

06. 0625_w19_MS_63 Q: 2

(a)(i)	$u = 5.0(\text{cm})$ <u>and</u> $v = 7.6(\text{cm})$	1
(a)(ii)	$U = 25(.0)(\text{cm})$ <u>and</u> $V = 38(.0)(\text{cm})$	1
(a)(iii)	f_1 15(.1)(cm) <u>and</u> 2/3 sig fig and unit	1
(a)(iv)	move screen slowly / backwards and forwards	1
(b)(i)	$h_o = 1.5(\text{cm})$ <u>and</u> $h_i = 2.4(\text{cm})$	1
(b)(ii)	$M = 1.6$ <u>and</u> no unit	1
(b)(iii)	$f_2 = 15 / 14.6(\text{cm})$	1
(c)	statement matching results	1
	values within limits of experimental accuracy / owtte	1
(d)	any one from: <input type="checkbox"/> mark position of lens on holder ; <input type="checkbox"/> clamp rule / place rule on bench ; <input type="checkbox"/> ensure screen, lens <u>and</u> object all perpendicular (to bench) / vertical ; <input type="checkbox"/> view scale perpendicularly ; <input type="checkbox"/> mark top and bottom of image and measure later	1
(e)	either method suggested if matching valid explanation e.g. METHOD 1: difficult to measure height of image in method 2 METHOD 1: smaller lengths measured in method 2 / reverse argument METHOD 2: can't measure u and v to lens accurately in method 1	1

07. 0625_s18_MS_61 Q: 3

(a)	uv values 1065, 1128, 1200, 1283, 1353	1
(b)	Graph: (all marks are still available if uv values are wrong) Axes correctly labelled and right way round	1
	Suitable scales	1
	All plots correct to $\frac{1}{2}$ small square	1
	Good line judgement, thin, continuous line	1
(c)	Triangle method clearly shown on graph	1
	Triangle using at least half of candidate's line	1
(d)	G in range 14.0 to 16.0	1
	$f = G$ to 2 or 3 significant figures	1
(e)	Any two from: Finding exact position that gives clearest image Measuring to centre of lens Room too bright/lamp too dim/image too faint	2

08. 0625_s18_MS_62 Q: 3

(a)(i)	$v = 5.8(0)$ (cm) / 58 (mm)	1
(a)(ii)	$V = 29(.0)$ (cm)	1
(a)(iii)	$f_1 = 11.8(3673)$ / 12 (cm)	1
(b)	$f_A = 12.0$ (cm)	1
	2 or 3 significant figures	1
(c)	at least 3 new values suggested	1
	all new values between 15 cm and 70 cm with at least 5 cm between each value	1
(d)	any two from: use of darkened room / brighter lamp mark position of centre of lens on holder place metre rule on bench / clamp in position ensure object and (centre of) lens are same height (from the bench) object <u>and</u> lens <u>and</u> screen perpendicular to bench move screen slowly / back and forth to obtain best image	2

09. 0625_s18_MS_63 Q: 3

(a)	$h_o = 1.4$ (cm)	1
(b)(i)	$h_I = 4.5$ (cm)	1
(b)(ii)	$N = 0.31$ / ecf	1
(c)	graph:	
	axes labelled correct orientation, with quantity and unit	1
	appropriate scales (plots occupying at least $\frac{1}{2}$ grid)	1
	plots all correct to $\frac{1}{2}$ small square and precise plots	1
	well judged line and thin line	1
(d)	G in range 14.0 to 17.0	1
	triangle method seen on graph occupying at least half line	1
(e)	any inherent difficulty e.g. hand / ruler in way of image OR screen can move (when measuring)	1
	matching improvement to <u>apparatus</u> e.g. use translucent screen and view from behind OR fix ruler / grid to screen OR clamp screen in place	1

Paper Perfection, Crafted With Passion

10. 0625_w18_MS_61 Q: 3

(a)(i)	Normal through block and at centre of AB	1
(a)(ii)	$i = 30^\circ$ on correct side of normal	1
(a)(iii)	P_1 and P_2 at minimum distance apart of 5.0 cm	1
(b)(i)	Line through P_3 and P_4 straight and continued to NL	1
(b)(ii)	a in range 17 mm to 21 mm	1
(b)(iii)	b in range 55 mm to 56 mm and both a and b with correct unit	1
(b)(iv)	n in range 1.31–1.65, 2 or 3 significant figures	1
(c)	$n = 1.5$ or 1.53 , both n with no unit	1
(d)	Any two from: Getting pins vertical / pins are bent Lining up the pins exactly / seeing pins clearly Drawing accurate / thin lines Replacing block accurately on outline / outline larger than block / owtte	2
(e)	3rd box (view bases of pins)	1

11. 0625_w18_MS_62 Q: 3

(a)(i)	normal at centre of AB (by eye) produced to cross CD	1
(a)(ii)	$i = 30^\circ \square 1^\circ$ drawn to the left of the normal	1
(a)(iii)	P_1 and P_2 in air at minimum distance apart of 5.0cm	1
(b)	line through P_3 and P_4 neat, straight and continued to N	1
(c)(i)	$a = 55 \square 1$ (mm)	1
(c)(ii)	$b = 37 \square 1$ mm and both with correct unit	1
(c)(iii)	n within the range $1.42 \square 1.60$ if 3 s.f. quoted, or within the range 1.4 to 1.6 if 2 s.f. quoted	1
	2 or 3 significant figures with no unit	1
(d)	at least two additional angles suggested	1
	between 10° and 60° inclusive with at least 5° difference between values	1
(e)	any one from: large pin separation / pins at least 5 cm apart ensure that the pins are vertical / upright / perpendicular to the paper / placed straight view the bases of the pins use thin pencil lines / thin pins	1

12. 0625_w18_MS_63 Q: 3

(a)(i)	$\alpha = 20^\circ \pm 1^\circ$	1
(a)(ii)	normal correct	1
(a)(iii)	pin separations ≥ 5.0 cm	1
(b)(i)	line in correct place and neat	1
(b)(ii)	$\theta = 40^\circ \pm 1^\circ$	1
(c)(i)	line in correct place and neat	1
(c)(ii)	$\theta = 68^\circ \pm 1^\circ$	1
(d)	statement matching results including qualitative justification (e.g. 'within limits of experimental accuracy' / owtte)	1
	justification that makes use of the data to support statement	1
(e)	Any two suitable precautions: pins upright / view pins at base; thin pins; thin lines / sharp pencil; large pin separations; ensure mirrored surface lies along drawn line.	2

13. 0625_m17_MS_62 Q: 3

(a)	$h_1 = 4.5$ (cm)	1
(b)	correct M calculations – 3.00/ecf, 1.50, 0.73, 0.50, 0.37	1
(c)	graph: axes labelled with quantity and unit	1
	appropriate scales (plots occupying at least $\frac{1}{2}$ grid)	1
	plots all correct to within $\frac{1}{2}$ small square	1
	well judged line <u>and</u> single, continuous thin line	1
(d)	construction line(s) clearly seen <u>on graph</u>	1
	u in range 28.0 to 32.0 (cm)	1
(e)	any appropriate difficulty: e.g. hand / ruler in way of image	1
	matching improvement: e.g. use translucent screen and view from behind, fix ruler / grid to screen	1
(f)	able to achieve a sharp / complete / focused image / owtte	1
Total:		11

14. 0625_s17_MS_61 Q: 2

(a)	Normal in centre of AB and CD and FE at 30° to normal	1
	P ₁ P ₂ distance at least 5 cm	1
(b)	P ₃ P ₄ line and KE correctly drawn (to K)	1
(c)	α in range 28–32	1
	x in range 20–24 (mm)	1
(d)	Statement matches readings (Expect YES, owtte)	1
	Justification to include the idea of within (or beyond, ecf) the limits of experimental accuracy	1
(e)	Any one from: Large pin separation Ensure pins vertical / upright / erect View bases of pins Use thin pencil lines / thin pins	1
Total:		8

15. 0625_s17_MS_62 Q: 2

(a)	normal in centre of AB at the top face	1
	FE at 40° to the left of the normal	1
	P ₁ P ₂ distance at least 5 cm	1
(b)	P ₃ P ₄ straight line and K correctly marked on CD	1
(c)	$\alpha = 40 \pm 2$	1
	$x = 17 \pm 2$ mm	1
(d)	statement is a definite YES or NO, depending on candidate's measured value of x	1
	justification to include the idea of within the limits of experimental accuracy/(very)close/almost equal etc. if YES	
	justification to include the idea of outside the limits of experimental accuracy/too far apart/too different etc. if NO	1
(e)	any one from: large pin separation/pins must be >5 cm apart ensure pins vertical/upright/perpendicular to the paper view bases of pins use thin pencil lines/thin pins	1
Total:		9

Paper Perfection, Crafted With Passion

16. 0625_s17_MS_62 Q: 3

(a)	50 – 200 cm inclusive	1
(b)	move (the screen) <u>slowly/carefully back and forth</u> until the best position is found	1
(c)	9.966/9.97/10 cm	1
	answer to 2/3 significant figures (regardless of value – even if incorrect)	1
(d)	upside down/magnified/fainter/coloured	1
(e)	A, D, F	3
Total:		8

17. 0625_s17_MS_63 Q: 3

(a)	$\theta = 30^{\circ} \pm 1^{\circ}$	1
(b)	distance $\geq 5 \text{ cm} \leq 15 \text{ cm}$	1
(c)(i)	normal correct	1
(c)(ii)	$a = 6.4 \text{ (cm)}$ <u>and</u> $b = 4.3 \text{ (cm)}$	1
(c)(iii)	$n = 1.49$ or ecf	1
	2 or 3 sig figs <u>and</u> no unit	1
(d)(i)	all lines in correct places and neat	1
	$\alpha = 28^{\circ} \pm 3$	1
(d)(ii)	statement matching results	1
	justification matching the statement ('within limits of experimental accuracy' / owtte)	1
(e)	difficulty in aligning pins / placing pins accurately, pins (too) thick	1
Total:		11

18. 0625_w17_MS_61 Q: 2

(a)(i),(ii)	$v = 6.0$ AND $d = 8.0$ or $v = 60$ AND $d = 80$	1
	correct matching unit	1
(b)(i),(ii),(iii)	$V = 60 \text{ cm}$ (or 10 \square candidate's v) and $D = 80 \text{ cm}$ (or 10 \square candidate's d)	1
	$UV 1200$ (ecf)	1
(c)	One from: Different size Different brightness Sharpness / clearness / coloured edges	1
(d)(i),(ii),(iii)	f values 15(.0) and 14.9 (14.87)	1
	f_A correct method	1
	2 or 3 significant figures	1
(e)	Any two from: Difficulty deciding exact position of sharpest image Difficulty measuring to centre of lens Product uv increases problem Image edges blurred / not clear Insufficient sets of results	2
(f)(i)	5 – 10	1
(f)(ii)	Difference of at least 40 cm with a range 15–100	1

19. 0625_w17_MS_62 Q: 3

(a)	Graph	
	axes correctly labelled	1
	suitable scales	1
	all plots correct to $\frac{1}{2}$ small square	1
	good best-fit curve judgement thin, continuous line based on all the plots	1
(b)(i)	2 points and straight line correct	1
(b)(ii)	u_1 and v_1 read correctly to $\frac{1}{2}$ small square	1
(b)(iii)	correct (calculation of) f from candidate's values f value <u>rounding to</u> 14 – 16cm	1
(c)	any two from: upside down less bright / brighter coloured edges different sizes	2
(d)	any two from: darkened room / bright object object AND lens AND screen perp. to bench / vertical object and lens same height (from bench) move <u>screen</u> (not lens) slowly / backwards and forwards clamp rule / fix rule to bench	2

20. 0625_w17_MS_63 Q: 4

MP1	additional apparatus: screen AND (metre) rule	1
MP2	diagram: suitable arrangement of apparatus with u & v labelled correctly	1
MP3	method: obtain (clear focused) image AND measure u , v	1
MP4	repeat for other values of u	1
MP5	one precaution for clear, focused image: move screen slowly / backwards and forwards, object AND lens AND screen perpendicular to bench / vertical, object and lens at same height (from bench), use of dark room / bright light	1
MP6	one precaution with measurements: clamp rule / fix to bench, mark centre of lens on holder avoidance of parallax explained and specific	1
MP7	one additional point: additional precaution, calculate f from <u>given equation</u> at least 3 values obtained, calculate average, mention of at least one appropriate u value, mention of preliminary expt to obtain rough f value (e.g. light from window)	1

21. 0625_m16_MS_62 Q: 3

- (a) (i) normal correct [1]
(ii) $\theta = 40^\circ$ [1]
- (b) P_1, P_2 marked on line NM and separation > 5.0 cm [1]
- (c) (i) thin lines all in correct place [1]
 $a = 8.1$ to 8.3 (cm) and $b = 5.2$ to 5.5 (cm) [1]
(ii) n correctly calculated [1]
2/3 sig figs and no unit [1]
- (d) any two suitable precautions: [2]
e.g.
 - view pins from base/ensure pins upright,
 - large pin separations
 - use of thin pencil lines/sharp pencil/thin pins
 - repeat with different angles

[Total: 9]

22. 0625_s16_MS_61 Q: 5

(a)	$u = 50, v = 21$	1
(b)(i)	$U = 500, V = 210$ ecf from (a)	1
(b)(ii)	$f_1 = 148$ or 150 or 147.9 (mm) ecf from (i) 2 or 3 significant figures	1
		1
(c)	$f_2 = 136$ (mm) c.a.o.	1
(d)	Yes/statement is correct, owtte	1
	(6 mm) difference is very small / within limits of experimental error / Difference explained by uncertainty in her focal length measurement	1
(e)	Any two from: Use of darkened room/brighter lamp Mark position of centre of lens on holder Place metre rule on bench (or clamp in position) Ensure object and (centre of) lens are same height (from the bench) Object and lens and screen perpendicular to bench Move <u>screen</u> (slowly) back and forth to obtain best image (owtte) Ensure rule is touching object/lens/holder/screen or look perpendicular to ruler	2
		Total 9

23. 0625_s16_MS_62 Q: 3

(a)	$m_1 = 2.94$	1
(b)	$(m_2 = 0.329 \text{ OR } 0.33) m_1 \text{ and } m_2$ to 2 or 3 significant figures only AND both m with no unit (accept \times)	1
(c)	Statement, expect YES. Must match results. e.c.f. allowed	1
	Justification to include idea of within (or beyond) limits of (experimental) accuracy	1
(d)	Any two from: <ul style="list-style-type: none"> • Use of darkened room/brighter lamp/no other lights • Mark position of centre of lens on holder • Place metre rule on bench (or clamp in position) • Ensure object and centre of lens are same height from the bench • Move lens slowly/to and fro (when focussing) • Lens, object, screen vertical/perpendicular to bench • Repeat with different D • Use of graph paper/cm scale on screen to measure image 	max 2
(e)	image appears well focused over a (small) range of lens positions/not all of image focussed at same time/relevant reference to chromatic aberration	1
		Total: 7

24. 0625_s16_MS_63 Q: 3

	apparatus: diagram – lens, (illuminated) object, screen in suitable order for experiment	1
	in line on flat surface	1
	instructions: set/measure object distance, move screen to get image, measure image height,	1
	repeat for different object distances	1
	limiting factor for range of object distances – one from: <ul style="list-style-type: none"> • image virtual/too big for screen, • image too dim/too small to measure, • must be greater than focal length 	1
	graph: image size/magnification against object distance	1
	precaution: any one suitable precaution <u>and</u> consequence of not taking it, e.g. <ul style="list-style-type: none"> • dark room/bright light – image might not be distinct, • lens and object at same height – image might not appear on screen, • lens, object and screen perpendicular – image might be distorted, • fix rule – may move and give incorrect distances • mark position of lens on holder – cannot judge correct measurements/owtte • detailed means of obtaining a sharp image – might not be correctly focused • means of measuring image height accurately – might be obscured 	1
		Total: 7

25. 0625_w16_MS_61 Q: 3

(a)	Ray trace: $i = 20$	1
(b)(i)	P at least 5 cm from the block	1
(b)(ii)	Greater accuracy with greater distance owtte OR easier to line up accurately	1
(b)(iii)	19°	1
(c)	Graph: θ 19 (or ecf), 29,41,51,59 i 20, 30, 40, 50, 60 Axes correctly labelled and right way round Suitable scales All plots correct to $\frac{1}{2}$ small square Good line judgement, thin, continuous line	1 1 1 1
(d)	Triangle method shown on graph <u>and</u> triangle using at least half of candidate's line G 0.9 – 1.1	1 1
Total:		10

26. 0625_w16_MS_62 Q: 5

(a)(i)	8.4 cm / 84 mm	1
(a)(ii)	initial BP_2 distance at least 5.0 cm	1
(b)	graph: axes correctly labelled suitable scales all plots correct to $\frac{1}{2}$ small square good line judgement, thin, continuous line	1 1 1 1
(c)	statement to match graph – expect NO justification to match statement with reference to graph line	1 1
(d)	any two from: difficult to judge when pins are exactly in line difficult to ensure that pins are vertical/straight thickness of lines thickness of pins protractor only measures to $\pm 1^\circ$	2×1
Total:		10

27. 0625_w16_MS_63 Q: 2

(a)(i)	$h_0 = 1.5$ (cm) $h_1 = 4.0$ (cm)	1 1
(a)(ii)	$M = 2.7$ (or ecf) <u>and</u> no unit for M	1
(a)(iii)	Answer given to 2/3 sig figs <u>and</u> with appropriate unit Value given for f_1 rounds to 14.5 or 14.6 (cm)	1 1
(a)(iv)	any appropriate difficulty: e.g. hand / ruler in way of image	1
	matching improvement: e.g. use translucent screen and view from behind use transparent ruler, fix ruler / grid to screen	1
(b)(i)	distance present, and $v = 25(.0)$ (cm)	1
(b)(ii)	f_2 present (expect 15.4 (cm)) <u>and</u> statement matching results	1
	justification matching correct statement ('within limits of experimental accuracy' / owtte)	1
(c)	any suitable precaution: e.g. dark room / bright light (centre of) lens and object same height (above bench), lens / object / screen perpendicular (any one will suffice), ruler fixed / placed on bench, mark centre of lens on holder repeat with different values of u / different sizes of object	1
	Total	11

28. 0625_m15_MS_62 Q: 4

- (a) (i) $u_1 = 5.0$ (cm)/50(mm) [1]
 $v_1 = 8.7$ (cm)/87(mm) [1]
- (ii) correct calculation of f , expect 3.1 to 3.2 (cm)/31 to 32 (mm), e.c.f.(a)(i) [1]
matching unit [1]
- (b) u_2 in range 8.8 to 8.9(cm)/88 to 89(mm) AND statement matching results [1]
appropriate justification e.g. within limits of experimental accuracy owtte [1]
- (c) two appropriate precautions, e.g. [2]
- carry out experiment in dark room/no direct (sun)light/bright lamp
 - lens and object same height above bench
 - lens, object and screen vertical
 - move screen/lens back and forth/slowly to obtain sharp image
 - fix/place rule on bench
 - mark centre of lens on holder
 - readings repeated

[Total: 8]

29. 0625_s15_MS_61 Q: 4

- (a) (i) normal at centre of AB and through block [1]
(ii) GH parallel to AB AND 6 cm \pm 2 mm above AB [1]
(iii) $i = 30^\circ \pm 2^\circ$ to left of normal [1]
- (b) P_1P_2 distance ≥ 5.0 cm [1]
- (c) line KE correct, single and straight, emergent ray through P_3 and P_4 [1]
- (d) $a = 3.3 - 3.7$ (cm); $b = 6.8 - 7.2$ (cm); $c = 4.0 - 4.4$ (cm); $d = 1.4 - 1.8$ (cm) [1]
 n in range 1.2–1.5, no unit, 2 or 3 significant figures [1]
- (e) any one from:
 - large pin separation
 - ensure pins are vertical
 - view bases of pins
 - drawing thin lines/use a sharp pencil
 - use thin pins[1]
- (f) ray box near start of incident ray or anywhere on incident ray; pointing in correct direction [1]

[Total: 9]

30. 0625_s15_MS_62 Q: 4

- (a) normal labelled NL [1]
- (b) P_1P_2 distance > 5 cm, < 30 cm [1]
- (c) (i) Graph:
 - axes correctly labelled [1]
 - suitable scales [1]
 - all plots correct to $\frac{1}{2}$ small square [1]
 - good line judgement [1]
 - thin, continuous line [1]
- (ii) no [1]
line does not pass through origin [1]
- (iii) difficulty in aligning pins OR pins too thick OR thickness of mirror [1]

[Total: 10]

31. 0625_s15_MS_62 Q: 5

(a) $f = 15.06(387)$ [1]

final answer given to 2 or 3 significant figures AND unit [1]

(b) any two from:

- darkened room / bright(er) lamp / no other lights
- moving screen slowly / back and forth to obtain best image
- mark block to show centre of lens
- place rule on bench/ clamp rule;
- lens and object same (vertical) height/level (from bench)
- lens, object and screen vertical/perpendicular to bench;
- repeat measurement/experiment (and average)

[max.2]

(c) any two from:

- upside down/inverted
- size/bigger
- brightness/brighter/dimmer
- colours seen round edge/edges blurred

[max.2]

[Total: 6]

32. 0625_s15_MS_63 Q: 4

(a) (i) $f = 3.1$ [1](ii) $F = 15.5$ allow ecf [1](b) $F_1 = 15.6$ allow ecf [1](c) $F_2 = 15.7$ [1]

statement matching results [1]

appropriate justification, including idea of within limits of experimental accuracy owtte [1]

(d) appropriate precaution e.g: [1]

- carry out experiment in dark room/no direct (sun)light/bright lamp
- lens and object same height (above bench)
- lens, object and screen/mirror vertical/perpendicular
- move screen/lens back and forth/slowly to obtain sharp image
- fix/place rule on bench/clamp rule
- mark centre of lens on holder
- readings/expt repeated (and average taken)

[Total: 7]

33. 0625_w15_MS_61 Q: 3

- (a)(i)(ii)** ray-trace:
- normal at 90° and crossing **MR** at intersection with P_3P_4 line [1]
 - incident ray at $30^\circ \pm 2^\circ$ in correct quadrant [1]
 - incident ray 8.0 cm long [1]
- (b)** **B** to **X** at least 5.0 cm [1]
- (c)** **(i)** P_3P_4 line correctly drawn AND all lines single, thin, continuous lines [1]
- (ii)** $r = 31^\circ - 33^\circ$ [1]
- (d)** any two from:
- ensure pins are vertical/view bases of pins
 - pins far apart (or > 5 cm)
 - ensure mirror exactly on **MR**/ensure mirror does not move
 - thin lines/sharp pencil/thin pins
 - repeats [2]
- (e)** any one from:
- thickness of lines/pencil/mirror/pins
 - difficulty of lining up pins and images [1]

[Total: 9]

34. 0625_w15_MS_61 Q: 5

- (a)** in correct order: object, lens, screen [1]
all three components on bench and all perpendicular to bench [1]
- (b)** 50–100 (cm) [1]
- (c)** any two from:
- difficulty in deciding exact position of lens for best image/image not quite clear
 - difficulty in measuring to centre of lens
 - room too bright/lamp too dim [2]
- (d)** image shown upside down [1]

[Total: 6]

35. 0625_w15_MS_62 Q: 4

- (a)(i)(ii) ray-trace:
- normal drawn at centre of **MR** [1]
 - incident ray at $30^\circ (\pm 1^\circ)$ [1]
 - incident ray 8.0 cm long [1]
- (b) P_1P_2 distance ≥ 5 cm apart [1]
- (c) (i) all lines correctly drawn AND all lines single, thin, continuous lines [1]
- (ii) $r = 27^\circ$ – 30° [1]
- (d) any two from:
- ensure pins are vertical/view bases of pins
 - pins far apart (or ≥ 5 cm)
 - thin lines/sharp pencil/thin pins [2]
- (e) any one from:
- thickness of mirror/mirror glass silvered at back surface
 - thickness of pins
 - difficulty in lining up pins (and their images exactly) [1]
- [Total: 9]**
-

36. 0625_w15_MS_63 Q: 5

- (a) normal correct, through **N** [1]
- (b) (i) line in correct place, **F**, labelled AND line and normal both thin, continuous and straight lines [1]
- (ii)(iii) one measurement of a or b correct ($a = 7.3$, $b = 4.1$ – 4.2) AND unit of cm or mm [1]
both measurements correct AND unit of cm or mm [1]
- (c) 1.7–1.8 AND no unit [1]
- (d) any one from: [1]
- ensure pins are vertical/view bases of pins
 - pins far apart (or > 5 cm)
 - thin lines/sharp pencil/thin pins
 - view from small angle (to normal)
- (e) less reliable AND reference to smaller block depth owtte [1]
measuring smaller lengths gives greater (%) uncertainties owtte [1]
- [Total: 8]**
-

- (a) angle of incidence 30° and **AB** 8.0 cm single, continuous, straight line [1]
- (b) P₃P₄ line correct and neat [1]
 $\alpha_0 = 30 \pm 1^\circ$ [1]
- (c) **graph:**
 axes correctly labelled and correct way round [1]
 suitable scales, i.e. y-axis 2 cm = 20° , x-axis 2 cm = 10° [1]
 all plots correct to $\frac{1}{2}$ small square [1]
 good line judgement [1]
 single, thin, continuous line, neat points [1]
- (d) triangle method seen on graph with triangle using at least half of line [1]
 G between 1.9 and 2.1, ecf for axes wrong way round [1]
- (e) $(\alpha - \alpha_0) = 2\theta$ or words to that effect, no ecf [1]
- (f) any one from:
 large(r) pin separation
 view bases of pins (or ensure pins vertical)
 repeat and average
 thin(ner) pins
 thin(ner) lines/sharp(er) pencil [max 1]

Paper Perfection, Crafted With Passion

[Total: 12]

38. 0625_s14_MS_62 Q: 4

- (a) (i) x and y clearly and correctly labelled to centre of lens [1]
- (ii) $d = 40.9(\text{cm})$ no mark
- (iii) $d^2 = 1673(\text{cm}^2)$ no mark
- (iv) $f = 14.8 / 14.77$ correct answer only [1]
ignore sig. figs, but penalise incorrect rounding
- cm **and** 2 or 3 sig. figs. [1]
- (b) any two from:
- use of darkened room/brighter lamp/no other lights
 - mark position of centre of lens on holder
 - place metre rule on bench/clamp in position
 - ensure object and (centre of) lens are same height (from the bench)
 - repeat (and average)
 - move the lens slowly/to and fro
 - lens, object and screen all vertical/perpendicular to bench [max 2]
- (c) (i) **two points in either order:**
- one magnified, other diminished owtte [1]
- one brighter than the other [1]
- (ii) both inverted/both real [1]
accept same way up/same shape
- (d) distance between object and screen/ D /change position of screen [1]

[Total: 9]

- (a) (i) $w = 2.6$ to 2.5 and $h = 2.5$ to 2.4 [1]
- (ii) $s = 2.6$ or correct rounding from candidate's values [1]
- (iii) appropriate reason e.g.
- w and h not always the same (NOT 'increase at different rates') (need reference to square shape – NOT just 'distorted')
 - difficult to measure shadows/edges not distinct
 - card might not be perpendicular/card might be tilted
 - lamp is not a point source
 - improve reliability
- [1]
- (b) axes labelled with quantity and unit [1]
- scales appropriate, plots covering at least $\frac{1}{2}$ grid [1]
- plots correct to $\frac{1}{2}$ small square [1]
- well judged curve [1]
- thin, continuous line, precise plots [1]
- (c) large gap between plots for 25 and 15 cm [1]
- allow gaps becoming larger/ to ensure curve is consistent
- NOT 'more plots, more accurate', 'make line more accurate'
- (d) any suitable reason e.g.
- shadow would be too big (for screen)
 - difference between w and h becomes larger
 - shadows become less distinct/ more blurred/ too distorted
- [1]

[Total: 10]

Paper Perfection, Crafted With Passion

40. 0625_w14_MS_61 Q: 1

- (a) normal at 90° , straight, at centre [1]
- (b) incident ray at 30° on left of normal, straight [1]
- (c) ray box near beginning of incident ray and pointing along it [1]
- (d) reflected ray at angle of reflection approximately 30° [1]
- (e) any two from:
darkened room/brighter ray box
mark rays at centre/edge of beam
use sharp pencil
thin ray/small slit in ray box
perpendicular viewing of protractor [2]

[Total: 6]

AcelGCSE
Paper Perfection, Crafted With Passion

41. 0625_w14_MS_61 Q: 4

- (a) $u = 20\text{ mm}$ AND $v = 58\text{ mm}$ [1]
- (b) $v/u = 2.9$ e.c.f. from (a) no unit [1]
- (c) $U = 200, V = 580$ e.c.f. from (a) [1]
- (d) 1.5 cm OR 15 mm [1]
- (e) statement to match results (expect yes) [1]
- justified by reference to results, communicating idea of within (beyond, ecf) limits of experimental accuracy [1]
- (f) any two from:
use of darkened room/brighter lamp
mark position of centre of lens on holder
place metre rule on bench (or clamp in position)
ensure object and (centre of) lens are same height (from the bench)
repeats and average
moving lens/object/screen back and forth (to find sharpest image) owtte
screen and lens and object all perpendicular to bench [2]
- (g) image inverted [1]
- (h) any one from:
darkened room/brighter lamp
moving lens/object/screen back and forth owtte
use object with fine detail e.g. cross-wires
measure at middle of range where image is sharp [1]

[Total: 10]

Ace IGCSE
Paper Perfection, Crafted With Passion

42. 0625_w14_MS_62 Q: 4

- (a) refracted ray in correct position and at $20^\circ \pm 1$ [1]
- (b) emergent ray in correct position and approximately parallel with incident ray [1]
note: allow a 3° tolerance
- all lines present and neat [1]
- (c) (i) P_3P_4 distance far apart, at least 5.0 cm [1]
- (ii) any two from: [2]
viewing bases of pins/ensure that pins are vertical/not bent
large pin separations
use of repeats
use of thin pencil lines (or equivalent comment)
close one eye (when aligning pins)
use thin/sharp pins
ignore parallax error
NOT dark room
- (d) idea of within/beyond limits of experimental accuracy [1]

[Total: 7]

43. 0625_w14_MS_63 Q: 3

- (a) $h_o = 2.0$ (cm) [1]
- (b)(c) $h_I = 1.9$ (cm) [1]
- S values round to 1.1 (allow ecf), 1.3, 1.7, 2(.0), 2.2, 2.5 [1]
- (d) graph: [1]
axes labelled with quantity and unit and in correct orientation [1]
appropriate scales [1]
plots correct to $\frac{1}{2}$ small square [1]
well-judged straight line and thin continuous line, precise plots [1]
triangle method/information for gradient seen marked on graph [1]
- (e) (i) G calculated from at least $\frac{1}{2}$ line [1]
- (ii) f in range 15 – 19 (cm) [1]

[Total: 10]

44. 0625_s13_MS_61 Q: 4

- on ray trace:
one line drawn accurately through P_3P_4 or CD [1]
both lines in correct place, neat, thin and intersecting [1]
normals Y to MR and P_1 to MR correct [1]
 $b = 55 - 65$ (mm) [1]
- (d) statement matches results (expect Yes) [1]
idea of within (or beyond) experimental accuracy [1]
- (e) any one from:
large spaces between pins
make sure pins are vertical
observe bases of pins [1]
- [Total: 7]**

45. 0625_s13_MS_62 Q: 5

- (a) axes correctly labelled [1]
suitable scales (at least half the grid used) [1]
all plots correct to $\frac{1}{2}$ small square [1]
good line judgement [1]
thin continuous line and fine plots [1]
- (b) triangle method used and shown [1]
using at least half of line [1]
- (c) $f = 14.0 - 16.0$ (cm) [1]
 f to 2 or 3 significant figures with unit [1]
- (d) any two from:
darkened room / brighter lamp / no other lights
(centre of) lens and object same vertical height from bench
mark block at centre of lens
clamp rule or place on bench
lens, object and screen are vertical / perpendicular to bench
repeat the measurements
move the screen backwards and forwards (to get sharpest image) [2]
- [Total: 11]**

46. 0625_s13_MS_63 Q: 5

- (a) $u = 3.9$ (cm) and $d = 16.2$ (cm) [1]
 $m = 3.15/3.2$ and no unit allow e.c.f. [1]
- (b) $h_o = 2.0$ (cm) and $h_i = 6.5$ (cm) [1]
 $M = 3.25$ (2 or 3 sig. figs.) and no unit allow e.c.f. [1]
- (c) statement matching results (expect 'Yes' but allow e.c.f.) [1]
 justification matching statement [1]
 (expect 'within the range of experimental accuracy' o.w.t.t.e.) [1]
- (d) (i) blurred edge / hand in way of light [1]
 ensure focused properly / screen etc. vertical / attach scale/rule to screen /
 use translucent screen, measure at back [1]
- (ii) one suitable precaution (not used in (d)(i)) e.g. [1]
 darkened room
 mark position of lens on holder
object and lens same height
 ruler fixed to bench
all apparatus vertical/right angle to bench
 move screen back and forth (to obtain sharp image)

[Total: 9]

47. 0625_w13_MS_61 Q: 4

- (a) (i)(ii) $u = 26$ (mm) or 2.6 (cm) [1]
 $v = 44$ (mm) or 4.4 (cm) [1]
- (b) (i)(ii) 1144 mm^2 and 70 mm [1]
OR 11.44 cm^2 and 7.0 (or 7) cm
e.c.f. from (a)
- (iii) $x = 16$ or 16.3 or 16.34 (1.6 or 1.63 or 1.634) [1]
e.c.f. from (b)(i) and (ii)
- (c) $f = 16$ or 16.3 or 16.34 cm (160 or 163 or 163.4 mm) [1]
 f given to 2 or 3 significant figures [1]
- (d) up to 0.5 cm either side of 18.2 cm [1]
- (e) any two from: [2]
use of darkened room / brighter lamp / no other light interfering
mark position of centre of lens on holder
place metre rule on bench (or clamp in position)
ensure object and lens are same height from the bench
lens / object / screen perpendicular to bench
repeats
avoidance of parallax with action and reason

[Total: 9]

48. 0625_w13_MS_62 Q: 4

- (a) (i)(ii) $u = 25(\text{mm}), v = 42(\text{mm})$ [1]
- (iii)(iv) $uv = 1050(\text{mm}^2), u + v = 67(\text{mm})$ allow e.c.f. [1]
- (v) $f_1 = 15.7(\text{mm})$ 2 or 3 significant figures only allow e.c.f. [1]
- (b) (i)(ii) $uv = 1050(\text{mm}^2), u + v = 67(\text{mm}), \text{c.a.o.}$
- (iii) $f_2 = 15.7(\text{mm})$ accept any significant figures [1]
- (c) statement matches results (expect YES) [1]
 justification in terms of within or beyond limits of experimental accuracy (o.w.t.t.e.)
 accept values are equal without mention of experimental accuracy [1]
- (d) any two from:
 use of darkened room / brighter lamp / no other lights
 mark position of centre of lens on holder
 place metre rule on bench (or clamp in position)
 ensure object and (centre of) lens are same height (from the bench)
 lens / object / screen vertical/perpendicular to bench
 repeat (and average)
 move lens slowly (backwards and forwards when focusing) [2]
- (e) image drawn inverted [1]

[Total: 9]

49. 0625_w13_MS_63 Q: 4

- (a) normal correct and pin separation at least 5 cm [1]
- (b)(c) both reflected lines in correct place (through $P_3, P_4 / P_5, P_6$) and thin/neat [1]
 $\theta = 40^\circ$ within 1° [1]
 $\theta = 62^\circ$ within 1° [1]
- (d) definite statement matching results (expect 'Yes' but allow e.c.f. if difference $>10\%$)
and justification matching statement
(expect 'within the range of experimental accuracy' or o.w.t.t.e.) [1]
values from results shown/used (correctly w.r.t statement) [1]
- (e) any two suitable precautions:
thin lines / fine pencil
view protractor perpendicularly/parallax explained
lines through centre of pin holes
pins well separated
pins vertical/not bent/viewed at base
place mirror so that reflecting surface is on line o.w.t.t.e. [2]
- [Total: 8]**

50. 0625_s12_MS_61 Q: 4

- (a) d in range 79 to 80 (mm), 7.9 to 8.0 (cm) [1]
 $x = 61$ (mm) and consistent correct unit for both (mm or cm) [1]
 $D = 80$ (cm), $X = 61$ (cm) ecf from (i) and (ii) [1]
- (b) $f = 14.5$ (cm) allow ecf from (a) [1]
2 or 3 significant figures and correct unit [1]
- (c) Correct statement for results (expect Yes or wtte) [1]
Idea of within (or beyond) experimental accuracy or wtte [1]
Can only score if previous mark is scored
- (d) Any one from:
Use of darkened room
How to avoid parallax when taking readings
Movement of lens back and forth to obtain clearest image
Mark lens holder to show position of centre of lens
Metre rule clamped or on bench
Object, lens and screen all perpendicular to bench
Object and lens same height above bench [1]

[Total: 8]

51. 0625_s12_MS_62 Q: 4

- (a) Blocks parallel with ONE sphere completely between [1]
Rule correctly placed [1]
- (b) (i) Line of sight perpendicular to scale [1]
Line of sight along bottom of meniscus [1]
- (ii) 70 (cm³) [1]
- (iii) 0.53 cm³, 2 or 3 significant figures, with unit [1]

[Total: 6]

52. 0625_s12_MS_63 Q: 5

- (a) Trace: [1]
Normal at 90° in correct position [1]
N at 4 cm above AB and angle of incidence 20° [1]
a value 4.3 cm ± 1 mm correct answer only [1]
- (b) All correct lines drawn, thin and continuous [1]
a and b both with consistent, correct unit which matches figures [1]
b value 6.2 cm ± 3 mm correct answer only [1]
n value range 1.4 – 1.5 after rounding [1]
to 2 or 3 significant figures and no unit [1]
- (c) One from: [1]
Pins well spaced
Pins at least 5 cm apart
View bases of pins
Ensure pins vertical
Use thin lines
Sharp pencil
Use thin pins

[Total: 9]

53. 0625_w12_MS_61 Q: 4

- (a) Trace:
Normal at 90° in correct position [1]
Angle of incidence = 30° ($\pm 2^\circ$) [1]
- (b) P_1P_2 distance ≥ 5.0 cm [1]
 P_3P_4 line and line **GE** correctly and neatly drawn [1]
- (c) (i) $r = 18$ or 19 or 20 [1]
(ii) i/r value correct [1]
- (d) (i) i/r value 1.54 and both i/r values with no unit and to 2 or 3 significant figures [1]
(ii) Idea of within (or beyond) limits of experimental accuracy [1]

[Total: 8]

54. 0625_w12_MS_62 Q: 1

- Line 10 cm (± 0.1) (accept horizontal or vertical line) [1]
Normal correctly drawn [1]
Angle of incidence at 30° ($\pm 2^\circ$) [1]
Pins at least 5 cm apart [1]
- Any one from:
Thickness of lines (answer must refer to pencil lines, not light rays)
Difficulty in reading protractor to better than 2°
Thickness of pins [1]

[Total: 5]

Ace | GCSE
Paper Perfection. Crafted With Passion.

55. 0625_w12_MS_62 Q: 4

- (a) Table: uv values 894, 990, 1090, 1155, 1194. Accept 3 or 4 significant figures. [1]
 cm^2 and cm [1]
- (b) Graph: [1]
 Axes correctly labelled and scales suitable (100 $\text{cm}^2 = 2 \text{ cm}$ on y -axis and $5 \text{ cm} = 2 \text{ cm}$ on x -axis) [1]
 All plots correct to $\frac{1}{2}$ small square [1]
 Good line judgement [1]
 Thin, continuous line (penalise 'blobs') [1]
- (c) (i) Triangle method used and shown [1]
 Using at least half of line [1]
- (ii) $f = 14 - 16$ (accept numbers rounding to 14/16) [1]
 2 or 3 significant figures and unit [1]

[Total: 10]

56. 0625_w12_MS_63 Q: 4

- (a) (i) and (ii) $u = 7.0 \text{ cm}$ and $v = 5.2 \text{ cm}$ (or equivalent in mm) [1]
 (iii) $u = 0.350$ and $v = 0.260$ in table (ecf) to 3 sf [1]
- (b) Correct $\frac{1}{u}$ (2.86(ecf)) and $\frac{1}{v}$ (1.67, 2.55, 3.85 (ecf), 4.50, 5.10) [1]
- (c) Axes labelled (including units) and appropriate scales [1]
 Plots correct to $\frac{1}{2}$ small square [1]
 Well judged straight line [1]
 Thin line and small plots [1]
- (d) (i) and (ii) p and q values there and matching graph [1]
- (e) (i) and (ii) f within range 0.145 to 0.155 [1]
 2 or 3 significant figures and appropriate unit [1]

[Total: 10]