

4.4 Digital electronics

01. 0625_m22_qp_22 Q: 33

Two NAND gates are joined together as shown.

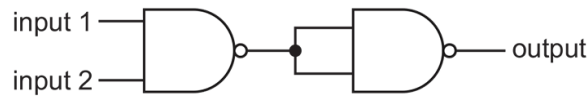

Which single logic gate is equivalent to this combination?

- A** AND **B** NAND **C** NOR **D** OR

02. 0625_m22_qp_22 Q: 34

The diagram shows an electric drill and safety guard.

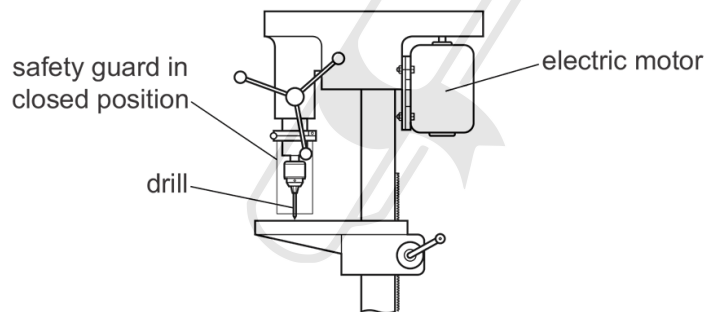

The drill requires the logic circuit shown.

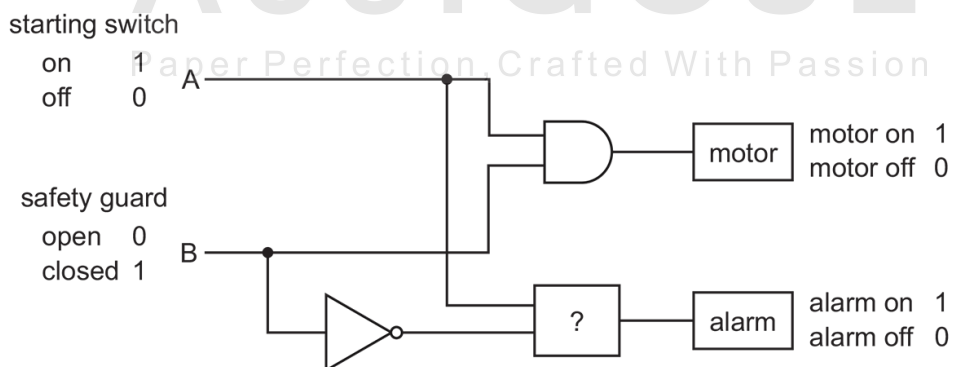

The circuit must only allow the motor to start when the safety guard is closed. If the safety guard is not closed when the starting switch is on, the alarm must sound.

Which logic gate is missing from the circuit?

- A** NOT **B** NAND **C** AND **D** NOR

4.4. DIGITAL ELECTRONICS

03. 0625_m21_qp_22 Q: 35

The circuit shown contains two gates.

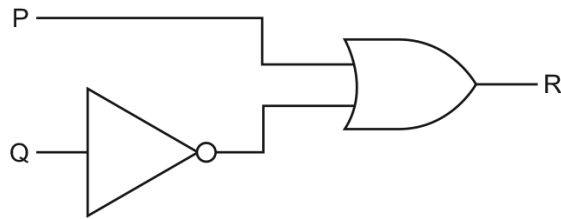

Which truth table describes the operation of the circuit?

A		
P	Q	R
0	0	0
0	1	1
1	0	1
1	1	1

B		
P	Q	R
0	0	0
0	1	0
1	0	1
1	1	1

C		
P	Q	R
0	0	1
0	1	0
1	0	0
1	1	0

D		
P	Q	R
0	0	1
0	1	0
1	0	1
1	1	1

04. 0625_s21_qp_21 Q: 33

Three NAND gates are connected in a single chip as shown.

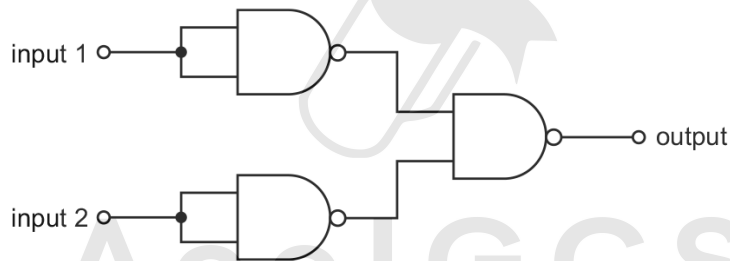

The whole chip behaves as a single logic gate.

Which type of logic gate does the chip act as?

- A AND gate
- B NAND gate
- C NOR gate
- D OR gate

05. 0625_s21_qp_22 Q: 34

The diagram shows a combination of four logic gates that produce an output signal at R that depends on the states of the inputs P and Q.

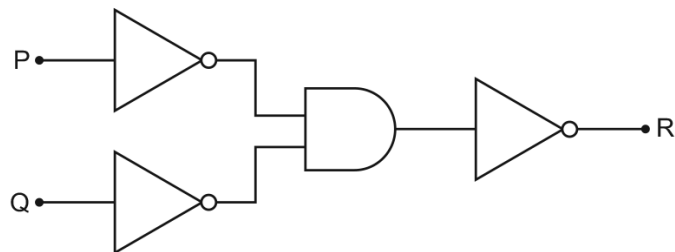

Which single logic gate produces the same effect as the combination?

- A** AND **B** NAND **C** NOR **D** OR

06. 0625_s21_qp_23 Q: 33

Which combination of two gates will result in the truth table shown?

P	Q	R
0	0	0
0	1	1
1	0	1
1	1	1

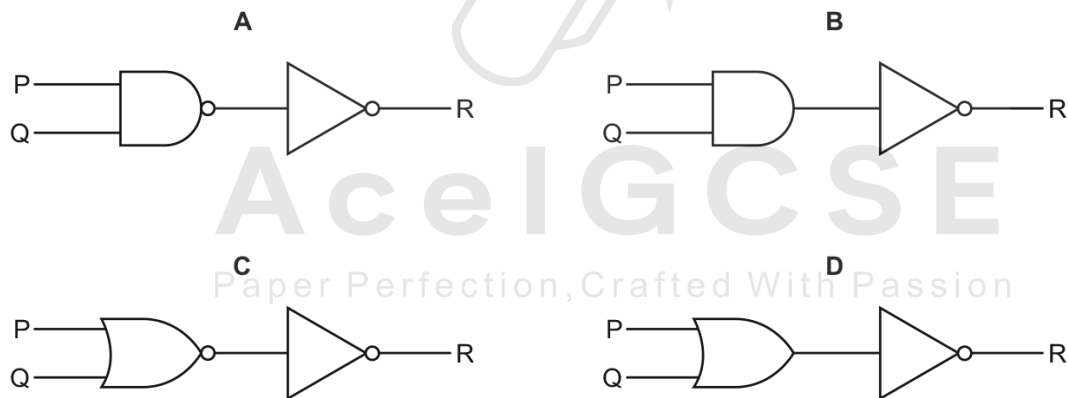

4.4. DIGITAL ELECTRONICS

07. 0625_w21_qp_21 Q: 30

The diagrams show pairs of circuits containing logic gates.

In which diagram does the lower circuit of the pair behave differently from the upper circuit?

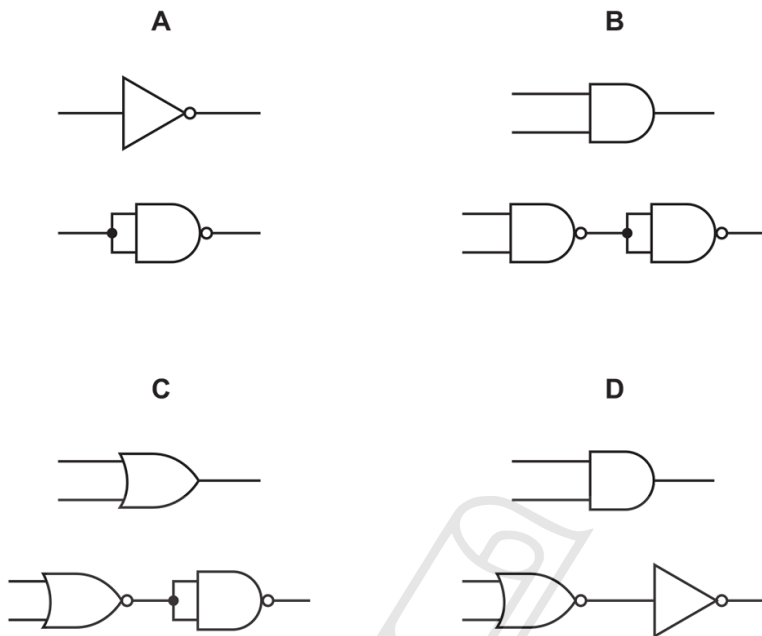

08. 0625_m20_qp_22 Q: 35

The two inputs of a NAND gate are joined together.



Which truth table represents the action of this gate?

A		B		C		D	
input	output	input	output	input	output	input	output
0	0	0	1	0	0	0	1
1	0	1	0	1	1	1	1

09. 0625_s20_qp_21 Q: 32

Which symbol represents an OR gate?



10. 0625_s20_qp_21 Q: 33

A digital circuit consists of two logic gates.

When the input to the circuit is 1 and 1, the output is 0.

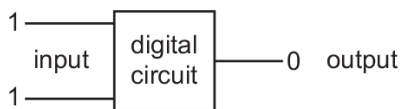

Which combination of logic gates gives this result?

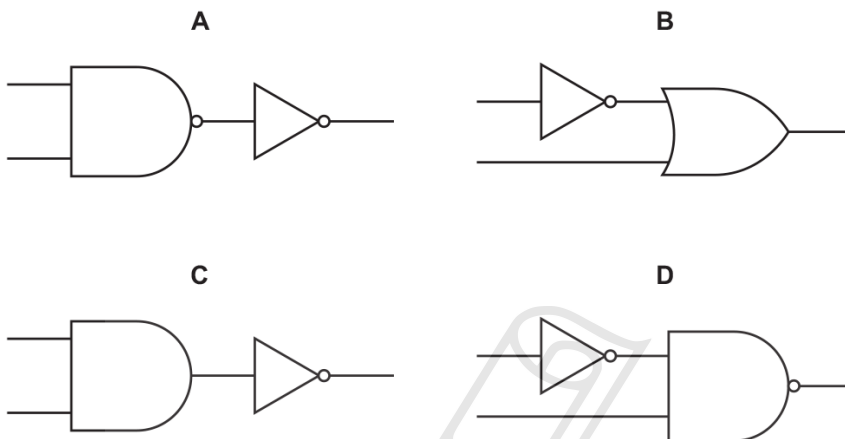

11. 0625_s20_qp_22 Q: 33

Which symbol represents a NAND gate?



12. 0625_s20_qp_23 Q: 33

Which two logic gates each have a high output when both of their inputs are high?

- A AND and OR
- B AND and NOR
- C NAND and NOR
- D NAND and OR

4.4. DIGITAL ELECTRONICS

13. 0625_s20_qp_23 Q: 34

The diagram shows a series of logic gates and part of its corresponding truth table.

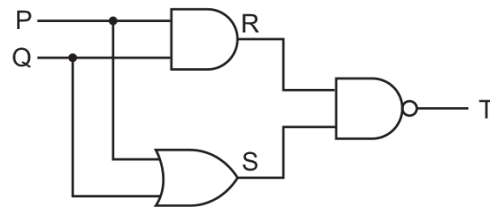

P	Q	R	S	T
0	0	0	0	1
0	1			
1	0	0	1	1
1	1	1	1	0

What are the missing values in row 2 of the truth table?

- A** 0 1 0 **B** 0 1 1 **C** 1 0 0 **D** 1 1 1
-

14. 0625_w20_qp_21 Q: 34

Which combination of logic gates gives the truth table shown?

inputs		output
X	Y	Z
0	0	1
0	1	1
1	0	1
1	1	0

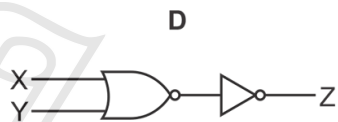
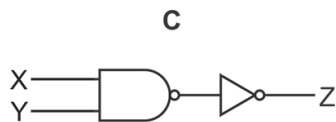
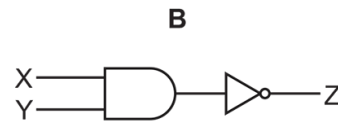
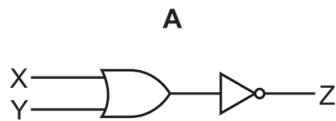

4.4. DIGITAL ELECTRONICS

15. 0625_w20_qp_22 Q: 33

Which combination of logic gates gives the truth table shown?

inputs		output
X	Y	Z
0	0	1
0	1	1
1	0	1
1	1	0

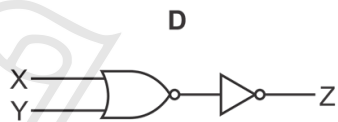
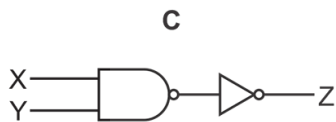
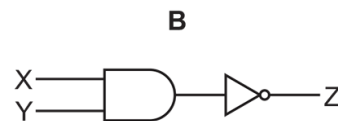
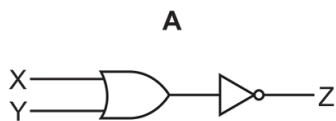

16. 0625_w20_qp_23 Q: 33

Which combination of logic gates gives the truth table shown?

inputs		output
X	Y	Z
0	0	1
0	1	1
1	0	1
1	1	0

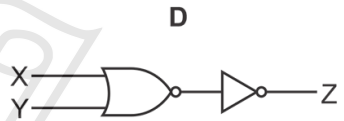
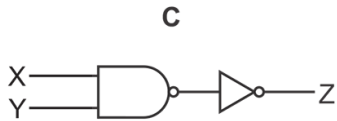
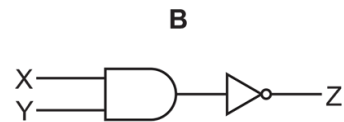
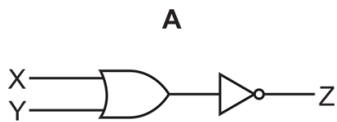

AceIGCSE
Paper Perfection, Crafted With Passion

4.4. DIGITAL ELECTRONICS

17. 0625_m19_qp_22 Q: 34

There are two inputs to the combination of logic gates shown, and one output.

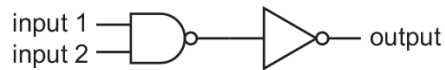

Which truth table represents the action of this combination of gates?

A

input 1	input 2	output
0	0	0
0	1	0
1	0	0
1	1	1

B

input 1	input 2	output
0	0	0
0	1	1
1	0	1
1	1	1

C

input 1	input 2	output
0	0	1
0	1	1
1	0	1
1	1	0

D

input 1	input 2	output
0	0	1
0	1	0
1	0	0
1	1	0

18. 0625_s19_qp_21 Q: 32

Which logic gate is represented by the symbol shown?



A AND

B NAND

C NOR

D OR

19. 0625_s19_qp_21 Q: 33

The diagram shows a combination of logic gates.

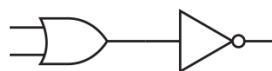

Which single logic gate is equivalent to this combination?

A AND

B NOR

C NOT

D OR

20. 0625_s19_qp_22 Q: 33

Which two logic gates each have a high output (1) when both of their inputs are low (0)?

- A AND and OR
- B AND and NOR
- C NAND and NOR
- D NAND and OR

21. 0625_s19_qp_22 Q: 34

Two NAND gates are joined together as shown.

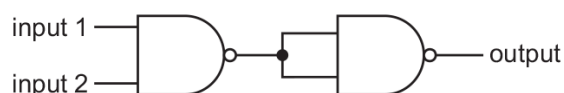

Which single logic gate is equivalent to this combination?

- A AND
- B NAND
- C NOR
- D OR

22. 0625_s19_qp_23 Q: 34

The combination of logic gates shown has two inputs and one output.

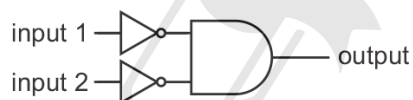

Which single logic gate is equivalent to this combination?

- A AND
- B NOR
- C NOT
- D OR

AcelGCSE
Paper Perfection, Crafted With Passion

4.4. DIGITAL ELECTRONICS

23. 0625_w19_qp_21 Q: 32

There are two inputs and one output for the combination of logic gates shown.

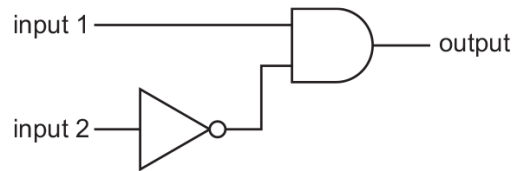

Which truth table represents the operation of this combination of logic gates?

A

input 1	input 2	output
0	0	0
0	1	0
1	0	1
1	1	1

B

input 1	input 2	output
0	0	0
0	1	0
1	0	1
1	1	0

C

input 1	input 2	output
0	0	1
0	1	1
1	0	0
1	1	0

D

input 1	input 2	output
0	0	1
0	1	0
1	0	1
1	1	1

24. 0625_w19_qp_22 Q: 33

Which single logic gate behaves the same as the combination of logic gates shown?

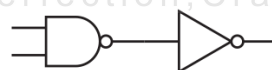

A AND

B NOR

C NOT

D OR

25. 0625_w19_qp_23 Q: 32

An AND gate has two inputs and one output.

Which truth table represents the action of the AND gate?

A

input 1	input 2	output
0	0	0
0	1	1
1	0	1
1	1	1

B

input 1	input 2	output
0	0	0
0	1	0
1	0	0
1	1	1

C

input 1	input 2	output
0	0	1
0	1	1
1	0	1
1	1	0

D

input 1	input 2	output
0	0	1
0	1	0
1	0	0
1	1	0

26. 0625_m18_qp_22 Q: 35

The diagrams show pairs of circuits containing logic gates.

In which diagram does the lower circuit of the pair **not** behave in the same way as the upper circuit?

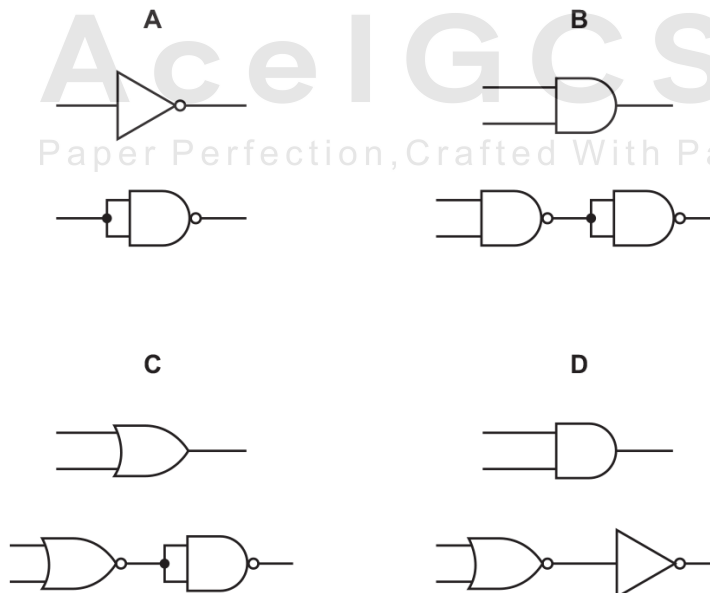

4.4. DIGITAL ELECTRONICS

27. 0625_s18_qp_21 Q: 33

The diagram represents a digital circuit using a NOR gate and an AND gate.

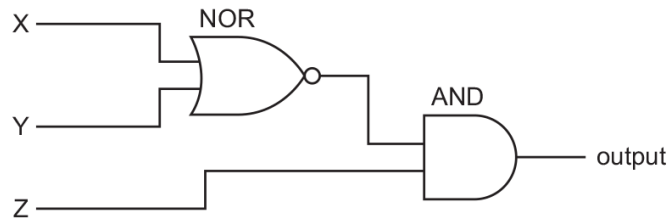

What is the truth table for this circuit?

A			
X	Y	Z	output
0	0	0	0
0	0	1	0
0	1	0	0
0	1	1	1
1	0	0	0
1	0	1	1
1	1	0	0
1	1	1	1

B			
X	Y	Z	output
0	0	0	0
0	0	1	1
0	1	0	0
0	1	1	0
1	0	0	0
1	0	1	0
1	1	0	0
1	1	1	0

C			
X	Y	Z	output
0	0	0	1
0	0	1	1
0	1	0	1
0	1	1	0
1	0	0	1
1	0	1	0
1	1	0	1
1	1	1	0

D			
X	Y	Z	output
0	0	0	1
0	0	1	0
0	1	0	1
0	1	1	1
1	0	0	1
1	0	1	1
1	1	0	1
1	1	1	1

28. 0625_s18_qp_23 Q: 33

The diagram shows a logic circuit with inputs X and Y.

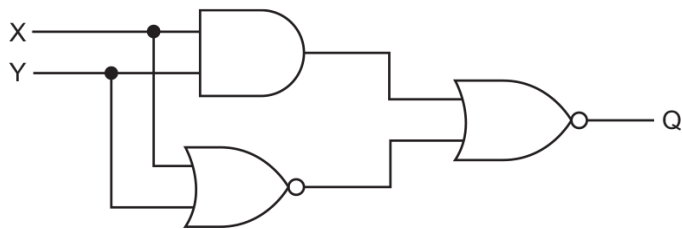

The output is Q.

Which truth table is correct?

X	Y	Q
0	0	0
0	1	1
1	0	1
1	1	0

X	Y	Q
0	0	1
0	1	0
1	0	0
1	1	1

X	Y	Q
0	0	1
0	1	1
1	0	1
1	1	1

X	Y	Q
0	0	0
0	1	0
1	0	0
1	1	0

29. 0625_w18_qp_21 Q: 33

The diagram shows a digital circuit with two inputs and one output.

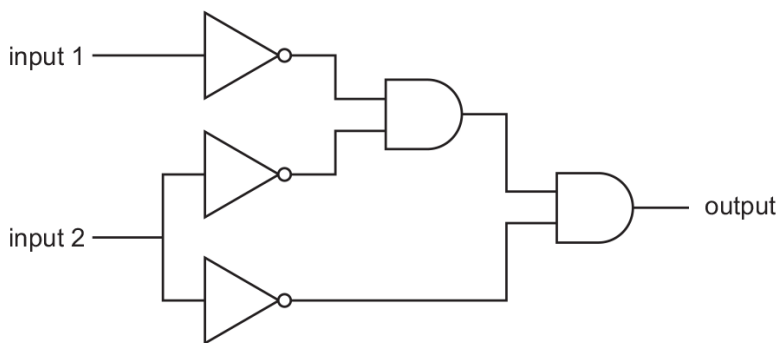

What describes the action of the circuit?

- A** AND **B** NAND **C** NOR **D** OR

4.4. DIGITAL ELECTRONICS

30. 0625_w18_qp_22 Q: 33

A logic gate has inputs 0,0 and an output 1.

Which two types of logic gate behave in this way?

- A OR, AND
- B OR, NAND
- C NOR, AND
- D NOR, NAND

31. 0625_w18_qp_23 Q: 32

Which symbol represents an AND gate?

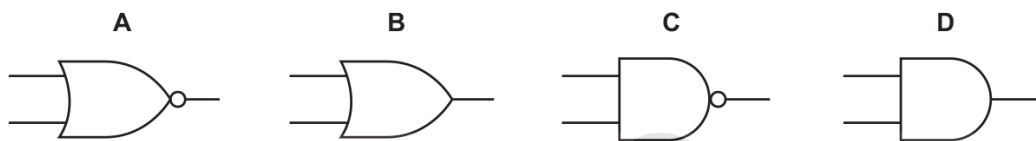

32. 0625_m17_qp_22 Q: 33

The truth table for a logic gate is shown.

input 1	input 2	output
0	0	1
0	1	0
1	0	0
1	1	0

Which type of logic gate is it?

- A AND
- B NOR
- C NOT
- D OR

33. 0625_s17_qp_21 Q: 34

The diagram shows a logic gate.

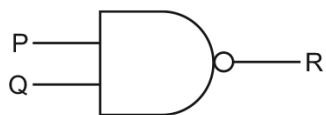

Which input combinations at P and Q gives an output of 0 at R?

	P	Q
A	0	0
B	0	1
C	1	0
D	1	1

34. 0625_s17_qp_22 Q: 34

What does the symbol shown represent?

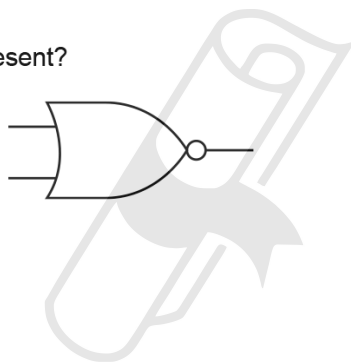

- A** an AND gate
- B** a NOR gate
- C** a NOT gate
- D** an OR gate

35. 0625_s17_qp_23 Q: 34

A truth table for a type of logic gate is shown.

input 1	input 2	output
0	0	0
0	1	1
1	0	1
1	1	1

Which type of logic gate is it?

- A** AND
- B** NOR
- C** NOT
- D** OR

4.4. DIGITAL ELECTRONICS

36. 0625_w17_qp_21 Q: 35

What does the symbol shown represent?

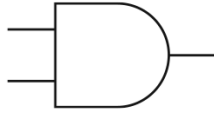

- A an AND gate
- B a NOR gate
- C a NOT gate
- D an OR gate

37. 0625_w17_qp_22 Q: 35

An incomplete truth table for a NAND gate is shown.

input P	input Q	output
0	0	W
0	1	X
1	0	Y
1	1	Z

What are the values of W, X, Y and Z?

	W	X	Y	Z
A	0	0	0	1
B	0	1	1	1
C	1	0	0	0
D	1	1	1	0

38. 0625_w17_qp_23 Q: 35

The diagram shows an AND gate and an OR gate connected together.

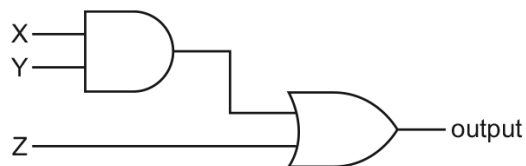

Which combination of inputs X, Y and Z gives an output of 0?

	X	Y	Z
A	0	0	1
B	0	1	1
C	1	0	0
D	1	1	0

39. 0625_s16_qp_21 Q: 31

The diagram shows a combination of logic gates.

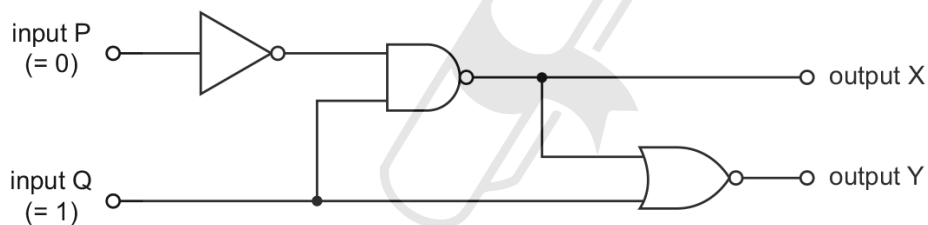

Input P is at a logic state 0 (low) and input Q is at a logic state 1 (high).

What are the logic states at output X and at output Y?

	output X	output Y
A	0	0
B	0	1
C	1	0
D	1	1

4.4. DIGITAL ELECTRONICS

40. 0625_w16_qp_21 Q: 34

This is the truth table for a logic gate.

input 1	input 2	output
0	0	1
0	1	1
1	0	1
1	1	0

Which symbol represents the logic gate?



41. 0625_w16_qp_22 Q: 34

Two NAND gates are connected together as shown.



The arrangement acts like a single logic gate.

What is the name of this single logic gate?

- A** AND **B** NOR **C** NOT **D** OR

42. 0625_w16_qp_23 Q: 34

The diagram shows two logic gates connected together.

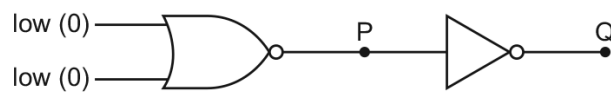

The two inputs are both low (0).

What are the logic states at P and at Q?

	P	Q
A	high (1)	high (1)
B	high (1)	low (0)
C	low (0)	high (1)
D	low (0)	low (0)

SN	Paper	Q. No.	Answer
01	0625_m22_qp_22	33	A
02	0625_m22_qp_22	34	C
03	0625_m21_qp_22	35	D
04	0625_s21_qp_21	33	D
05	0625_s21_qp_22	34	D
06	0625_s21_qp_23	33	C
07	0625_w21_qp_21	30	D
08	0625_m20_qp_22	35	B
09	0625_s20_qp_21	32	A
10	0625_s20_qp_21	33	C
11	0625_s20_qp_22	33	B
12	0625_s20_qp_23	33	A
13	0625_s20_qp_23	34	B
14	0625_w20_qp_21	34	B
15	0625_w20_qp_22	33	B
16	0625_w20_qp_23	33	B
17	0625_m19_qp_22	34	A
18	0625_s19_qp_21	32	C
19	0625_s19_qp_21	33	A
20	0625_s19_qp_22	33	C
21	0625_s19_qp_22	34	A
22	0625_s19_qp_23	34	B
23	0625_w19_qp_21	32	B
24	0625_w19_qp_22	33	A
25	0625_w19_qp_23	32	B
26	0625_m18_qp_22	35	D
27	0625_s18_qp_21	33	B
28	0625_s18_qp_23	33	A
29	0625_w18_qp_21	33	C
30	0625_w18_qp_22	33	D
31	0625_w18_qp_23	32	D
32	0625_m17_qp_22	33	B
33	0625_s17_qp_21	34	D
34	0625_s17_qp_22	34	B
35	0625_s17_qp_23	34	D
36	0625_w17_qp_21	35	A
37	0625_w17_qp_22	35	D
38	0625_w17_qp_23	35	C
39	0625_s16_qp_21	31	A
40	0625_w16_qp_21	34	C
41	0625_w16_qp_22	34	A
42	0625_w16_qp_23	34	B

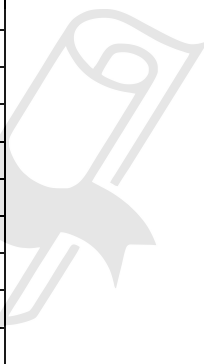

AcelGCSE
Perfection, Crafted With Passion