

## 4.2 Electrical quantities

01. 0625\_m22\_qp\_22 Q: 27

Two isolated metal spheres are both negatively charged. The spheres are brought close together but do not touch.

Which diagram shows the charge distribution on the spheres?

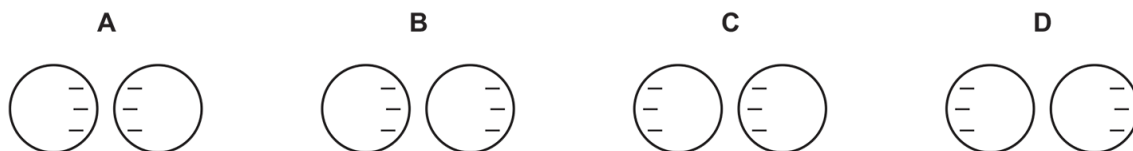

02. 0625\_m22\_qp\_22 Q: 28

Two separate circuits have different power supplies. Both power supplies provide the same magnitude current.

Power supply P has an electromotive force (e.m.f.) of 1.5 V and power supply Q has an e.m.f. of 3.0 V.

Which statements about Q are correct when compared with P?

- 1 Q supplies twice the charge per unit time.
- 2 Q supplies twice the energy per unit charge.
- 3 Q supplies twice the energy per unit time.

**A** 1, 2 and 3    **B** 1 and 2 only    **C** 1 and 3 only    **D** 2 and 3 only

03. 0625\_m22\_qp\_22 Q: 29

The diagram shows a piece of metal resistance wire.

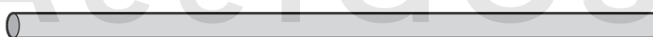

Which wire, made of the same metal, has a smaller resistance?

- A** a wire of the same length with a larger diameter
- B** a wire of the same length with a smaller diameter
- C** a wire of greater length with the same diameter
- D** a wire of greater length with a smaller diameter

4.2. ELECTRICAL QUANTITIES

04. 0625\_m21\_qp\_22 Q: 30

Two uncharged metal spheres X and Y rest on insulating stands and touch each other. A negatively charged plastic rod is brought near to sphere X.

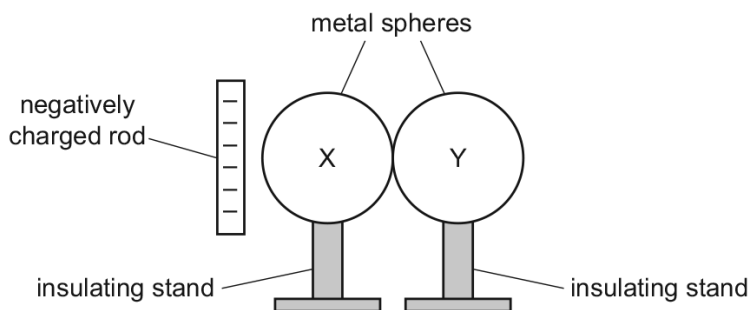

Using the insulating stand, sphere Y is moved away from sphere X.

What are the signs and the relative magnitudes of the charges induced on X and Y?

	charge on X	charge on Y	relative magnitudes of charges
<b>A</b>	negative	negative	equal
<b>B</b>	negative	positive	different
<b>C</b>	positive	negative	equal
<b>D</b>	positive	positive	different

05. 0625\_m21\_qp\_22 Q: 31

Which two changes to a metal wire both decrease its resistance?

	length of wire	cross-sectional area of wire
<b>A</b>	decrease	decrease
<b>B</b>	decrease	increase
<b>C</b>	increase	decrease
<b>D</b>	increase	increase

06. 0625\_m21\_qp\_22 Q: 32

There is a current  $I$  in a resistor of resistance  $R$  for a time  $t$ . The potential difference across the resistor is  $V$ .

Which equation gives the energy  $E$  transferred by the resistor?

- A**  $E = IR$       **B**  $E = IV$       **C**  $E = IRt$       **D**  $E = IVt$

07. 0625\_s21\_qp\_21 Q: 29

A student rubs a plastic rod with a cloth.

The rod becomes positively charged.

What has happened to the rod?

- A It has gained electrons.
- B It has gained protons.
- C It has lost electrons.
- D It has lost protons.

08. 0625\_s21\_qp\_21 Q: 30

An isolated metal sphere is positively charged.

It is then brought near to another isolated metal sphere that is neutral.

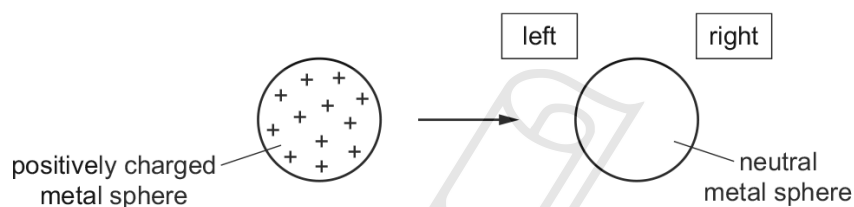

What happens to the charges on the neutral sphere as the positively charged sphere is brought close to it?

- A Some positive charges move to the left and some negative charges move to the right.
- B Some positive charges move to the right and some negative charges move to the left.
- C Some positive charges move to the right, but the negative charges do not move.
- D The positive charges do not move, but some negative charges move to the left.

09. 0625\_s21\_qp\_21 Q: 31

Which statement about the resistance of a metal wire is correct?

- A The resistance is directly proportional to its length and directly proportional to its cross-sectional area.
- B The resistance is directly proportional to its length and inversely proportional to its cross-sectional area.
- C The resistance is inversely proportional to its length and directly proportional to its cross-sectional area.
- D The resistance is inversely proportional to its length and inversely proportional to its cross-sectional area.

4.2. ELECTRICAL QUANTITIES

10. 0625\_s21\_qp\_22 Q: 30

A student rubs a plastic rod with a cloth.

The rod becomes positively charged.

What has happened to the rod?

- A It has gained electrons.
- B It has gained protons.
- C It has lost electrons.
- D It has lost protons.

11. 0625\_s21\_qp\_23 Q: 31

The diagram shows a circuit containing a cell, two resistors, a switch and a voltmeter.

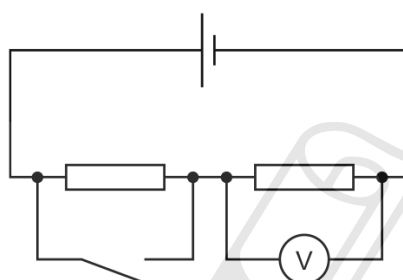

When the switch is open the voltmeter reads 1.5 V.

When the switch is closed the voltmeter reads 2.0 V.

What is the electromotive force (e.m.f.) of the cell?

- A 0.5 V
- B 1.5 V
- C 2.0 V
- D 3.5 V

12. 0625\_w21\_qp\_21 Q: 25

An uncharged, metal sphere is placed on an insulating support. A positively charged rod is brought close to the sphere, but does not touch it.

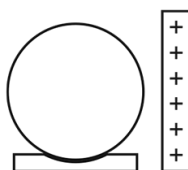

How do the charges in the sphere move and what is now the charge on the sphere?

	movement of charges	charge on sphere
A	negative charges move to the right of the sphere	positive
B	negative charges move to the left of the sphere	neutral
C	positive charges move to the left of the sphere	positive
D	positive charges move to the right of the sphere	neutral

4.2. ELECTRICAL QUANTITIES

13. 0625\_w21\_qp\_21 Q: 26

In which circuit is the ammeter measuring the flow of charge through the lamp?

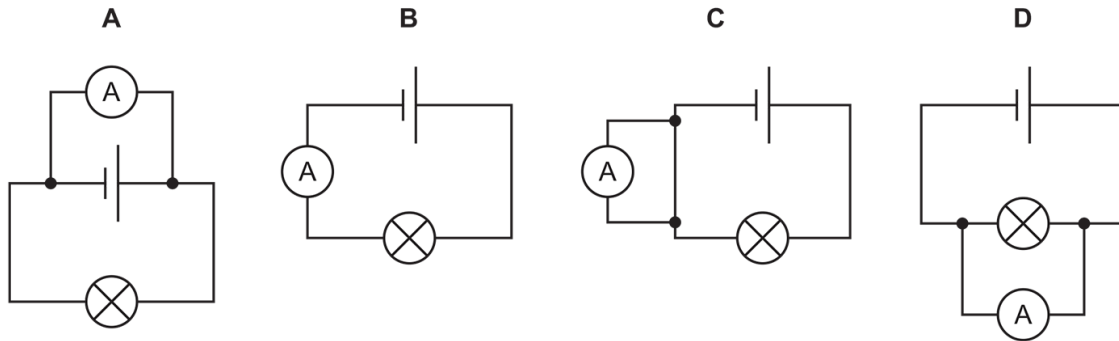

14. 0625\_w21\_qp\_21 Q: 27

A lamp is connected to a cell.

Which circuit diagram shows the direction of conventional current  $I$  and also the direction of flow of electrons  $e$ ?

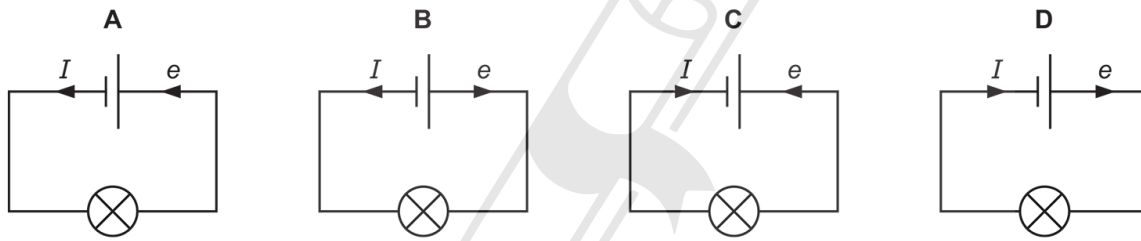

15. 0625\_w21\_qp\_22 Q: 25

Which diagram shows the electric field pattern between two oppositely charged parallel metal plates?

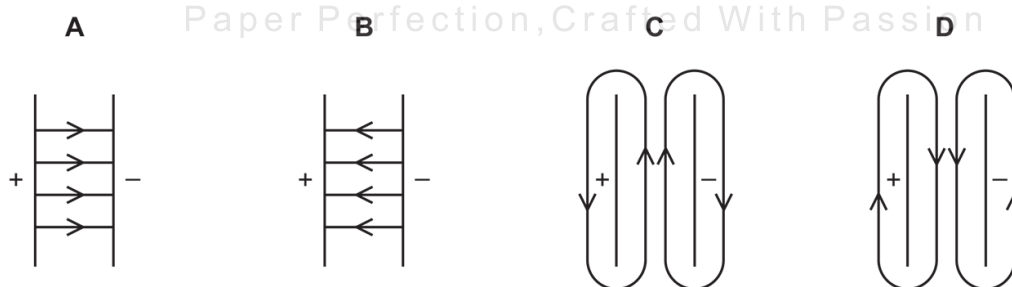

16. 0625\_w21\_qp\_22 Q: 26

Which circuit symbol represents a component used to measure electric current?



17. 0625\_w21\_qp\_22 Q: 27

The graph shows the current–voltage characteristic for a conductor.

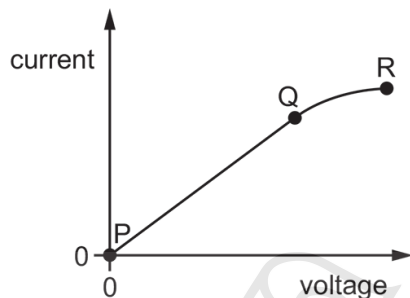

Where on the graph can Ohm's law be applied to the conductor?

- A at Q only
- B between P and Q
- C between P and R
- D between Q and R

18. 0625\_w21\_qp\_22 Q: 29

There is a current  $I$  in a resistor. The potential difference (p.d.) across the resistor is  $V$ .

Which other physical quantity is needed to be able to determine the energy transferred  $W$  by the resistor?

- A the electromotive force (e.m.f.)  $E$  of the source
- B the power  $P$  dissipated
- C the resistance  $R$  of the resistor
- D the time  $t$  for which there is a current in the resistor

## 4.2. ELECTRICAL QUANTITIES

19. 0625\_w21\_qp\_23 Q: 25

A stationary, charged particle is in a field.

Which fields can cause there to be a force on this particle due to its charge?

- 1 gravitational field
- 2 magnetic field
- 3 electric field

**A** 1 and 2      **B** 1 only      **C** 2 and 3      **D** 3 only

---

20. 0625\_w21\_qp\_23 Q: 26

An electric current in a copper wire is due to the flow of charge.

Which particles are moving along the wire?

- A**  $\alpha$ -particles
  - B** copper nuclei
  - C** electrons
  - D** protons
- 

21. 0625\_w21\_qp\_23 Q: 27

Which row is correct?

	definition of current $I$	direction of conventional current
<b>A</b>	$I = \frac{Q}{t}$	from positive terminal to negative terminal
<b>B</b>	$I = \frac{Q}{t}$	from negative terminal to positive terminal
<b>C</b>	$I = Q \times t$	from positive terminal to negative terminal
<b>D</b>	$I = Q \times t$	from negative terminal to positive terminal

---

22. 0625\_w21\_qp\_23 Q: 29

Which graph shows the current–voltage characteristic for a filament lamp?

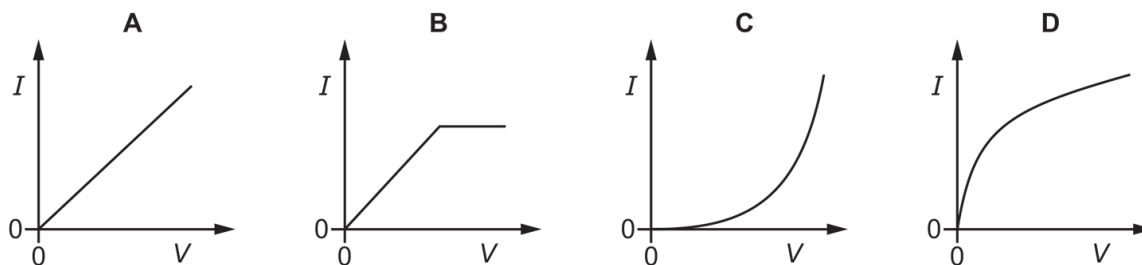

23. 0625\_w21\_qp\_23 Q: 34

Electrical energy is transferred by transmission lines at high voltage.

Which statement explains why a high voltage is used?

- A** The voltage is alternating.
- B** The transmission lines have a larger resistance.
- C** The transmission lines carry greater power.
- D** There is a smaller current in the transmission lines for the same power.

24. 0625\_m20\_qp\_22 Q: 30

Which row describes conventional current and electron flow in a circuit containing a cell?

	conventional current	electron flow
<b>A</b>	from the negative terminal of the cell to the positive terminal of the cell	from the negative terminal of the cell to the positive terminal of the cell
<b>B</b>	from the negative terminal of the cell to the positive terminal of the cell	from the positive terminal of the cell to the negative terminal of the cell
<b>C</b>	from the positive terminal of the cell to the negative terminal of the cell	from the negative terminal of the cell to the positive terminal of the cell
<b>D</b>	from the positive terminal of the cell to the negative terminal of the cell	from the positive terminal of the cell to the negative terminal of the cell

## 4.2. ELECTRICAL QUANTITIES

25. 0625\_m20\_qp\_22 Q: 31

A student makes four resistors using different pieces of wire. The wires have different diameters and lengths. All the pieces of wire are made of the same material.

Which piece of wire will make the resistor with the largest resistance?

	diameter / mm	length / cm
<b>A</b>	0.8	10
<b>B</b>	0.8	17
<b>C</b>	2.0	10
<b>D</b>	2.0	17

26. 0625\_p20\_qp\_20 Q: 29

A positively charged plastic rod is placed just above a thick metal plate. The metal plate rests on an insulator and is connected to the earth by a wire.

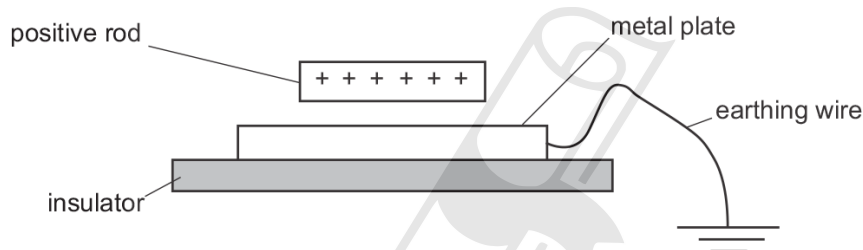

A student disconnects the earthing wire and then removes the positively charged rod.

The experiment is repeated. This time the student removes the positively charged rod and then removes the earthing wire.

Which statement is correct?

- A** When the earthing wire is disconnected first, the metal plate becomes positively charged.
- B** When the earthing wire is disconnected first, the metal plate becomes negatively charged.
- C** When the plastic rod is removed first, the metal plate becomes positively charged.
- D** When the plastic rod is removed first, the metal plate becomes negatively charged.

27. 0625\_p20\_qp\_20 Q: 30

The resistance of a wire depends on its length  $l$  and on its cross-sectional area  $A$ .

The resistance is

- A directly proportional to  $l$  and directly proportional to  $A$ .
- B directly proportional to  $l$  and inversely proportional to  $A$ .
- C inversely proportional to  $l$  and directly proportional to  $A$ .
- D inversely proportional to  $l$  and inversely proportional to  $A$ .

28. 0625\_p20\_qp\_20 Q: 31

In the circuit shown, the ammeter reads  $2.0\text{ A}$  and the voltmeter reads  $12\text{ V}$ .

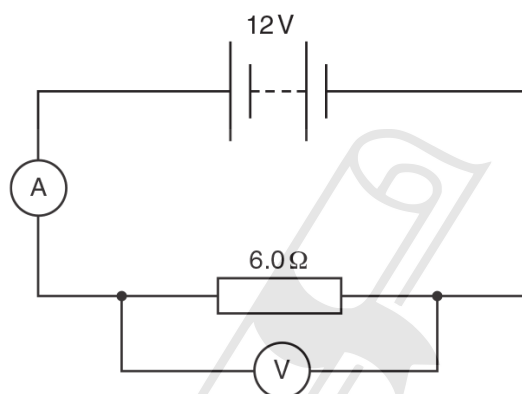

How much energy is transferred by the resistor in 10 seconds?

- A 2.4 J
- B 14.4 J
- C 240 J
- D 1440 J

AcelGCSE  
Paper Perfection, Crafted With Passion

29. 0625\_s20\_qp\_21 Q: 29

An electric fire is connected to a  $240\text{ V}$  supply and transfers energy at a rate of  $1.0\text{ kW}$ .

How much charge passes through the fire in  $1.0\text{ h}$ ?

- A 42 C
- B 250 C
- C  $1.5 \times 10^4\text{ C}$
- D  $2.4 \times 10^5\text{ C}$

## 4.2. ELECTRICAL QUANTITIES

30. 0625\_s20\_qp\_22 Q: 28

A cloth is used to rub an uncharged plastic rod.

Both the rod and the cloth become charged.

Why does the plastic rod become negatively charged and the cloth become positively charged?

- A The rod gains electrons and the cloth gains positive charges.
  - B The rod gains electrons and the cloth loses electrons.
  - C The rod loses electrons and the cloth gains electrons.
  - D The rod loses electrons and the cloth loses positive charges.
- 

31. 0625\_s20\_qp\_22 Q: 30

A cell passes a current of 2.0A in a circuit for 30s. In this time the cell transfers 120J of energy.

What is the electromotive force (e.m.f.) of the cell?

- A 0.50V
  - B 1.5V
  - C 2.0V
  - D 8.0V
- 

32. 0625\_s20\_qp\_23 Q: 28

The diagram shows a positively charged conducting sphere and a wire connected to earth.

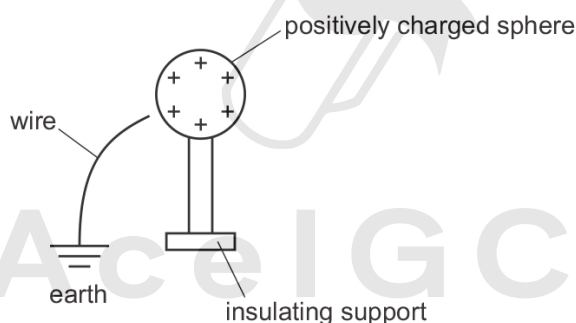

What happens when the wire is touched onto the sphere?

- A Electrons flow from earth to the sphere.
  - B Electrons flow from the sphere to earth.
  - C Positive charges flow from earth to the sphere.
  - D Positive charges flow from the sphere to earth.
- 

33. 0625\_s20\_qp\_23 Q: 30

There is a current of 2.0A in a resistor of resistance 8.0Ω.

How much power is dissipated in the resistor?

- A 0.25W
  - B 4.0W
  - C 16W
  - D 32W
-

34. 0625\_s20\_qp\_23 Q: 35

The graphs show how the currents in three circuits vary with time.

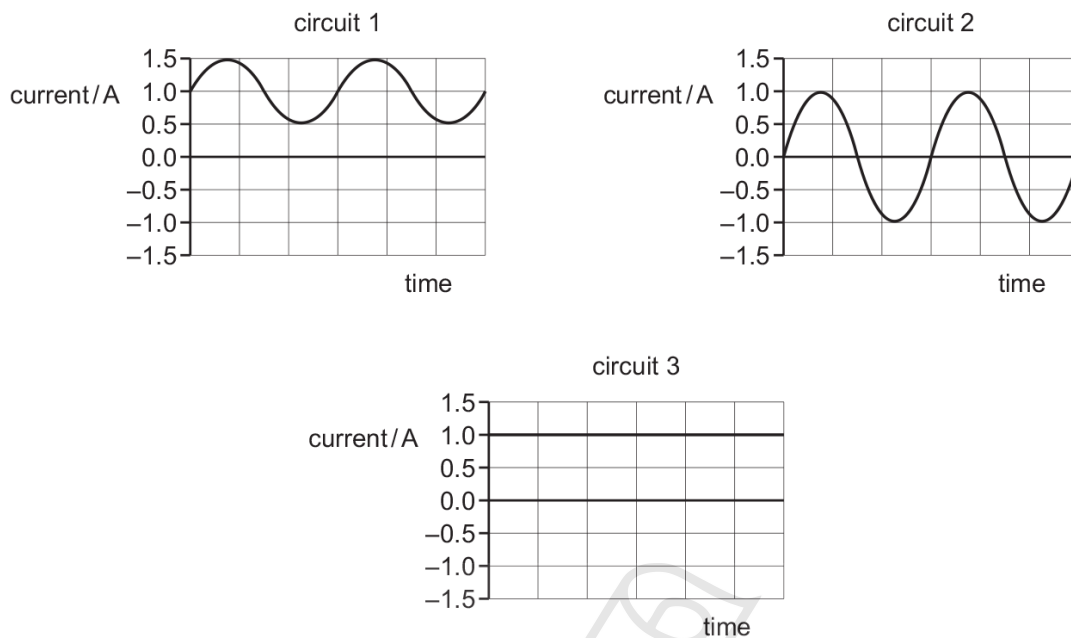

In which circuits is there a direct current?

- A** 1 and 2      **B** 1 and 3      **C** 2 only      **D** 3 only

35. 0625\_w20\_qp\_21 Q: 29

A negatively charged plastic rod is brought near to an uncharged metal sphere and held there.

What happens when the metal sphere is earthed?

- A** Electrons flow from the metal sphere to earth.  
**B** Electrons flow from earth to the metal sphere.  
**C** Positive charge flows from the metal sphere to earth.  
**D** Positive charge flows from earth to the metal sphere.

36. 0625\_w20\_qp\_21 Q: 30

Which statement defines the electromotive force (e.m.f.) of a cell?

- A** the current in the cell when 1.0 C of charge flows in 1.0 s  
**B** the current supplied by the cell to drive 1.0 C of charge around a complete circuit  
**C** the energy supplied by the cell to drive 1.0 C of charge around a complete circuit  
**D** the energy supplied by the cell to drive 1.0 A of current around a complete circuit

## 4.2. ELECTRICAL QUANTITIES

37. 0625\_w20\_qp\_21 Q: 31

Four wires are made of the same metal.

Which wire has the greatest resistance?

- A** a 100 cm long wire with a diameter of 3.0 mm
  - B** a 100 cm long wire with a diameter of 6.0 mm
  - C** a 10 cm long wire with a diameter of 3.0 mm
  - D** a 10 cm long wire with a diameter of 6.0 mm
- 

38. 0625\_w20\_qp\_22 Q: 30

Which quantity is defined as the energy transferred by a cell in driving unit charge around a complete circuit?

- A** current
  - B** electromotive force (e.m.f.)
  - C** power
  - D** resistance
- 

39. 0625\_w20\_qp\_22 Q: 31

There is a current in a variable resistor when a potential difference (p.d.) is applied across it.

In which situation is the current increased?

- A** Decrease the p.d. and keep the resistance the same.
  - B** Decrease the p.d. and increase the resistance.
  - C** Keep the p.d. the same and decrease the resistance.
  - D** Keep the p.d. the same and increase the resistance.
-

40. 0625\_w20\_qp\_23 Q: 29

A negatively charged cloud passes over a tall steel-framed building. A charge is induced on the building by the cloud because charges flow through the building.

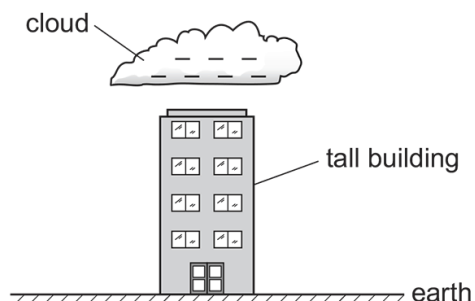

What charge is induced on the building and in which direction do the charge carriers move?

	charge induced on building	direction of charge flow
<b>A</b>	positive	from the building to earth
<b>B</b>	positive	from earth to the building
<b>C</b>	negative	from the building to earth
<b>D</b>	negative	from earth to the building

41. 0625\_w20\_qp\_23 Q: 30

Electromotive force (e.m.f.) is defined in terms of the energy supplied in driving which physical quantity around a complete circuit?

- A** charge
- B** current
- C** potential difference (p.d.)
- D** power

AcelGCSE  
Paper Perfection, Crafted With Passion

## 4.2. ELECTRICAL QUANTITIES

42. 0625\_m19\_qp\_22 Q: 29

A metal sphere is charged by induction. There are four stages W, X, Y and Z in this process.

- W a charged rod is brought near to the sphere
- X the sphere is earthed
- Y the charged rod is taken away from the sphere
- Z the earth connection is removed

In which order are the four stages carried out?

- A** W → X → Y → Z
  - B** W → X → Z → Y
  - C** Z → W → X → Y
  - D** X → Z → W → Y
- 

43. 0625\_m19\_qp\_22 Q: 30

Which electrical quantity is defined in terms of the energy supplied in driving charge round a complete circuit?

- A** current
  - B** electromotive force
  - C** potential difference
  - D** power
-

44. 0625\_s19\_qp\_21 Q: 27

Diagram 1 shows two thin, uncharged strips of plastic.

Diagram 2 shows the same strips after they have been rubbed with a dry cloth.

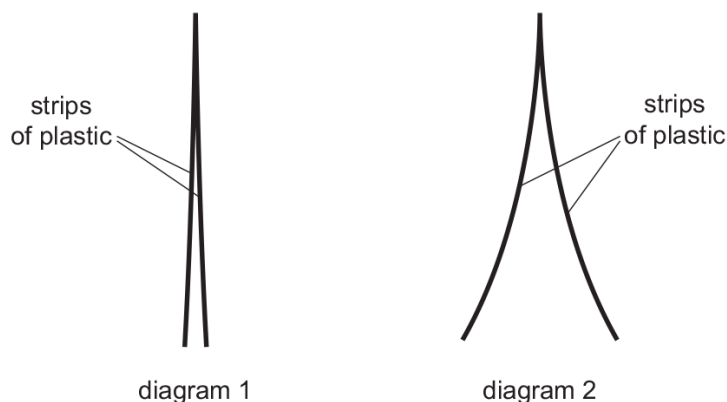

Which row describes the charge on the strips after rubbing, and the force between the strips after rubbing?

	charge on strips	force between strips
<b>A</b>	opposite	attraction
<b>B</b>	opposite	repulsion
<b>C</b>	the same	attraction
<b>D</b>	the same	repulsion

45. 0625\_s19\_qp\_21 Q: 28

A cell has an electromotive force (e.m.f.) of 1.5V.

What does this statement mean?

- A** The cell converts 1.0J of energy when driving 1.5C of charge round a complete circuit.
- B** The cell converts 1.5J of energy when driving 1.0C of charge round a complete circuit.
- C** The cell converts 1.5J of energy per second when driving 1.0C of charge round a complete circuit.
- D** The cell converts 1.5W of power when driving 1.0C of charge round a complete circuit.

## 4.2. ELECTRICAL QUANTITIES

46. 0625\_s19\_qp\_21 Q: 29

Which two changes to a metal wire both increase resistance?

- A decreasing its length and increasing its temperature
  - B increasing its length and decreasing its temperature
  - C decreasing its thickness and increasing its temperature
  - D increasing its thickness and decreasing its temperature
- 

47. 0625\_s19\_qp\_22 Q: 29

A metal wire of length 100 cm and cross-sectional area  $0.20 \text{ mm}^2$  has a resistance of  $8.0 \Omega$ .

What is the resistance of a wire of the same metal of length 50 cm and cross-sectional area of  $0.40 \text{ mm}^2$ ?

- A  $2.0 \Omega$       B  $8.0 \Omega$       C  $16 \Omega$       D  $32 \Omega$
- 

48. 0625\_s19\_qp\_23 Q: 29

Two wires X and Y are made from the same metal and have the same resistance.

Which row identifies a possible pair of values for X and for Y?

	length of X / cm	diameter of X / mm	length of Y / cm	diameter of Y / mm
A	50	0.40	200	0.10
B	50	0.40	200	0.20
C	50	0.40	200	0.80
D	50	0.40	200	1.60

---

49. 0625\_w19\_qp\_21 Q: 27

A plastic rod is rubbed with a dry cloth. The rod becomes positively charged.

Why has the rod become positively charged?

- A It has gained electrons.
  - B It has gained neutrons.
  - C It has lost electrons.
  - D It has lost neutrons.
-

50. 0625\_w19\_qp\_21 Q: 28

A circuit contains a cell of electromotive force (e.m.f.) of 2.0V. The current in the circuit is 2.0A.

How much energy is converted by the cell in 2.0 minutes?

- A** 2.0J      **B** 4.0J      **C** 8.0J      **D** 480J
- 

51. 0625\_w19\_qp\_22 Q: 29

There is a current of 2.0A in a resistor for 30s. The potential difference (p.d.) across the resistor is 12V.

How much energy is transferred in the resistor?

- A** 1.25J      **B** 5.0J      **C** 180J      **D** 720J
- 

52. 0625\_w19\_qp\_23 Q: 28

There is a current of 3.0A in a resistor for time  $t$ . During time  $t$ , a charge of 120C flows through the resistor.

What is time  $t$ ?

- A** 0.025 minutes  
**B** 0.025 s  
**C** 40 minutes  
**D** 40 s
- 

53. 0625\_m18\_qp\_22 Q: 30

A metal conductor is connected to a battery.

Which statement describes the current in the metal conductor?

- A** It is a flow of electrons from the negative to the positive terminal.  
**B** It is a flow of electrons from the positive to the negative terminal.  
**C** It is a flow of protons from the negative to the positive terminal.  
**D** It is a flow of protons from the positive to the negative terminal.
- 

54. 0625\_m18\_qp\_22 Q: 31

In an electric circuit, 40C of electric charge pass a point in 5.0s.

What is the current in the circuit?

- A** 0.13A      **B** 8.0A      **C** 45A      **D** 200A
-

## 4.2. ELECTRICAL QUANTITIES

55. 0625\_m18\_qp\_22 Q: 32

There is a current of 5.0 A in a resistor.

The potential difference (p.d.) across the resistor is 24 V.

How much energy is transferred in the resistor in 1.0 minute?

- A** 5.0 J      **B** 120 J      **C** 290 J      **D** 7200 J
- 

56. 0625\_s18\_qp\_21 Q: 27

The electromotive force (e.m.f.) of a rechargeable battery is 6.0 V.

What does this mean?

- A** 6.0 J is the maximum energy the battery can provide in 1.0 s.  
**B** 6.0 J is the total energy the battery can provide before it has to be recharged.  
**C** 6.0 J of energy is provided by the battery to drive a charge of 1.0 C around a complete circuit.  
**D** 6.0 J of energy is provided by the battery to drive a current of 1.0 A around a complete circuit.
- 

57. 0625\_s18\_qp\_21 Q: 28

A student measures the potential difference across a device and the current in the device.

Which calculation gives the resistance of the device?

- A** current + potential difference  
**B** current ÷ potential difference  
**C** potential difference ÷ current  
**D** potential difference × current
- 

58. 0625\_s18\_qp\_21 Q: 29

A water heater is connected to a 230 V supply and there is a current of 26 A in the heater. It takes 20 minutes to heat the water to the required temperature.

How much energy is supplied by the heater?

- A**  $6.0 \times 10^3$  J      **B**  $1.0 \times 10^4$  J      **C**  $1.2 \times 10^5$  J      **D**  $7.2 \times 10^6$  J
-

59. 0625\_s18\_qp\_22 Q: 27

What is the electromotive force (e.m.f.) of a cell?

- A** the amount of charge that passes through the cell per unit time
  - B** the energy gained per unit charge as charge passes through the cell
  - C** the total amount of charge flowing through the cell
  - D** the total energy stored in the cell
- 

60. 0625\_s18\_qp\_22 Q: 29

A piece of wire is 40 cm long and has a diameter of 2.0 mm.

Its resistance is  $0.30\Omega$ .

Which wire of the same material has a resistance of  $0.15\Omega$ ?

	length / cm	diameter / mm
<b>A</b>	20	1.0
<b>B</b>	20	4.0
<b>C</b>	80	1.0
<b>D</b>	80	4.0

---

61. 0625\_s18\_qp\_23 Q: 27

Two power supplies are connected in separate circuits. Both power supplies provide the same magnitude current.

Power supply P has an electromotive force (e.m.f.) of 1.5V and power supply Q has an e.m.f. of 3.0V.

Which statements are correct?

- 1 Source Q supplies twice the charge per unit time.
- 2 Source Q supplies twice the energy per unit charge.
- 3 Source Q supplies twice the energy per unit time.

**A** 1, 2 and 3    **B** 1 and 2 only    **C** 1 and 3 only    **D** 2 and 3 only

---

62. 0625\_s18\_qp\_23 Q: 29

An electricity meter records that 200 MJ of electrical energy are drawn from the 240 V mains supply in a 24 hour period.

What is the average rate of electrical charge passing through the meter?

**A** 9.6 C/h    **B** 580 C/h    **C** 35 kC/h    **D** 0.83 MC/h

---

4.2. ELECTRICAL QUANTITIES

63. 0625\_w18\_qp\_21 Q: 28

The diagrams represent two different electric fields.

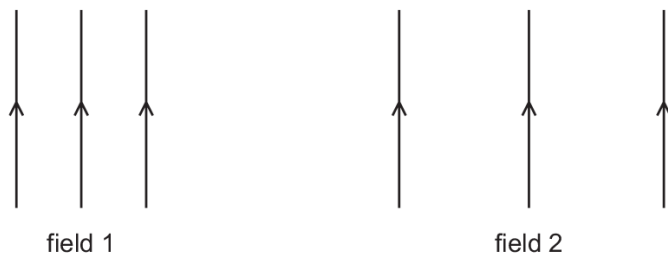

A single electron is located in each of the fields.

Which row gives the correct direction of the force on the electron and the field in which there is a larger force on it?

	direction of the force	larger force
<b>A</b>	↓	field 1
<b>B</b>	↓	field 2
<b>C</b>	↑	field 1
<b>D</b>	↑	field 2

64. 0625\_w18\_qp\_21 Q: 30

The table gives data for four different electrical devices.

Which device develops the greatest power?

	device	voltage	current
<b>A</b>	car headlight	12 V	3.0 A
<b>B</b>	cooling fan	110 V	0.40 A
<b>C</b>	electric spark generator	400 kV	0.10 mA
<b>D</b>	mains lamp	240 V	0.20 A

65. 0625\_w18\_qp\_22 Q: 27

The diagram shows point X between two charged plates.

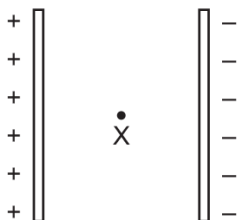

Which diagram shows the electric field pattern near point X?

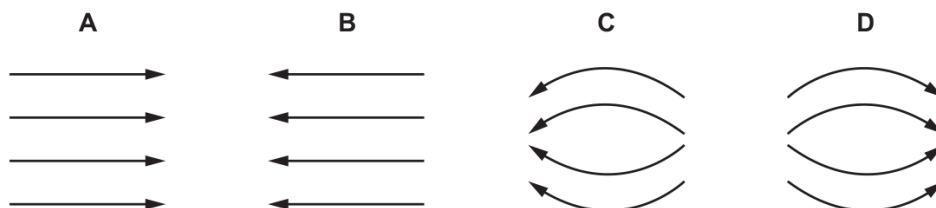

66. 0625\_w18\_qp\_22 Q: 29

Copper wire is available in fixed lengths but in various diameters  $d$ . Each diameter has a different resistance  $R$ .

Which relationship between  $R$  and  $d$  is correct?

- A  $R$  is directly proportional to  $d$ .
- B  $R$  is directly proportional to  $d^2$ .
- C  $R$  is inversely proportional to  $d$ .
- D  $R$  is inversely proportional to  $d^2$ .

67. 0625\_w18\_qp\_23 Q: 28

Which row shows the meaning of the quantity e.m.f. and the unit in which it is measured?

	meaning	unit
<b>A</b>	electromagnetic force	N
<b>B</b>	electromagnetic force	V
<b>C</b>	electromotive force	N
<b>D</b>	electromotive force	V

## 4.2. ELECTRICAL QUANTITIES

68. 0625\_w18\_qp\_23 Q: 29

Which diagram shows the current-voltage ( $I - V$ ) characteristic for a filament lamp?

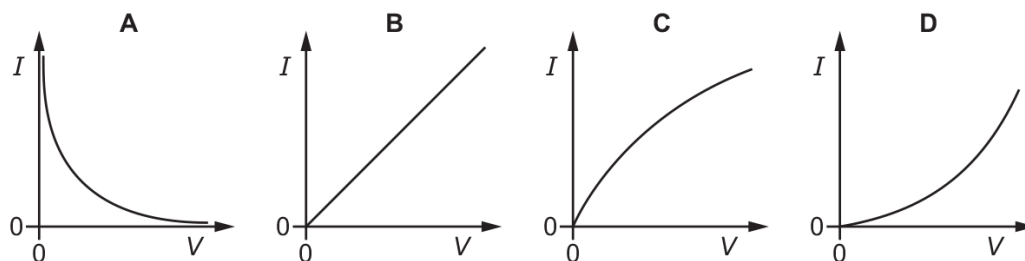

69. 0625\_w18\_qp\_23 Q: 31

The diagram shows part of an electric circuit. The reading on the voltmeter is  $16\text{V}$ . The current in the resistor is  $8.0\text{A}$ .

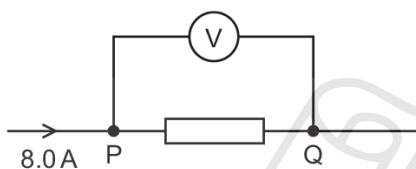

One coulomb of charge flows from P to Q through the resistor.

How much energy is transferred in the resistor?

- A** 2.0J      **B** 8.0J      **C** 16J      **D** 128J

70. 0625\_m17\_qp\_22 Q: 27

Which particles move in a metal to cause an electric current?

- A** electrons  
**B** neutrons  
**C** nucleons  
**D** protons

71. 0625\_m17\_qp\_22 Q: 28

The diagrams represent four copper wires.

Which wire has the greatest resistance?

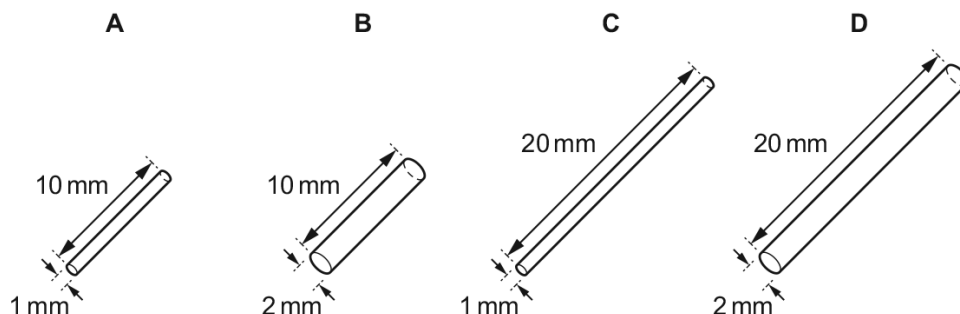

72. 0625\_m17\_qp\_22 Q: 29

An air-conditioning unit, a lamp and an electric fire all receive electrical energy from the mains supply.

From which of these devices is all this energy eventually transferred to the surroundings?

	air-conditioning unit	lamp	electric fire
<b>A</b>	✓	✓	✓
<b>B</b>	✓	✗	✓
<b>C</b>	✗	✓	✓
<b>D</b>	✗	✗	✓

key

✓ = all energy transferred to surroundings

✗ = not all energy transferred to surroundings

73. 0625\_s17\_qp\_21 Q: 27

A student rubs a plastic rod with a cloth.

The rod becomes positively charged.

What has happened to the rod?

- A** It has gained electrons.
- B** It has gained protons.
- C** It has lost electrons.
- D** It has lost protons.

4.2. ELECTRICAL QUANTITIES

74. 0625\_s17\_qp\_21 Q: 28

Which quantity is measured in coulombs?

- A charge
  - B current
  - C electromotive force
  - D power
- 

75. 0625\_s17\_qp\_21 Q: 29

A cylinder of conducting putty has length  $l$ , diameter  $d$  and resistance  $R$ . The putty is now moulded into a cylinder of diameter  $2d$  that has the same volume.

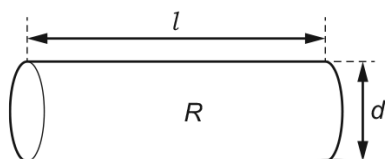

By which factor does the resistance of the putty cylinder decrease?

- A 2
  - B 4
  - C 8
  - D 16
- 

76. 0625\_s17\_qp\_21 Q: 30

The average current during a lightning strike between a cloud and the ground is  $1.5 \times 10^4$  A.

The lightning releases  $3.0 \times 10^8$  J of energy and lasts for  $2.0 \times 10^{-4}$  s.

What is the average electromotive force (e.m.f.) between the cloud and the ground?

- A 4.0 V
  - B 100 V
  - C  $1.0 \times 10^8$  V
  - D  $9.0 \times 10^8$  V
- 

Paper Perfection, Crafted With Passion

77. 0625\_s17\_qp\_22 Q: 27

A student tests the electrical conduction of four materials.

aluminium

iron

plastic

silver

Which materials conduct electricity?

- A aluminium, iron and silver only
  - B aluminium and silver only
  - C iron, silver and plastic only
  - D plastic only
- 

78. 0625\_s17\_qp\_22 Q: 28

What is the unit of charge?

- A ampere
  - B coulomb
  - C ohm
  - D volt
- 

79. 0625\_s17\_qp\_22 Q: 29

An isolated metal sphere is positively charged.

It is then brought near to another isolated metal sphere that is neutral.

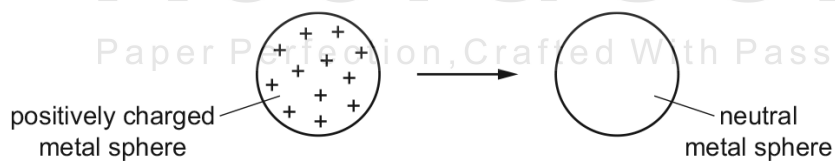

What happens to the charges on the neutral sphere as the positively charged sphere is brought close to it?

- A Some positive charges move to the left and some negative charges move to the right.
  - B Some positive charges move to the right and some negative charges move to the left.
  - C Some positive charges move to the right, but the negative charges do not move.
  - D The positive charges do not move, but some negative charges move to the left.
-

## 4.2. ELECTRICAL QUANTITIES

80. 0625\_s17\_qp\_22 Q: 30

Which diagram is the current-voltage ( $I$ - $V$ ) characteristic graph for a metallic conductor at constant temperature?

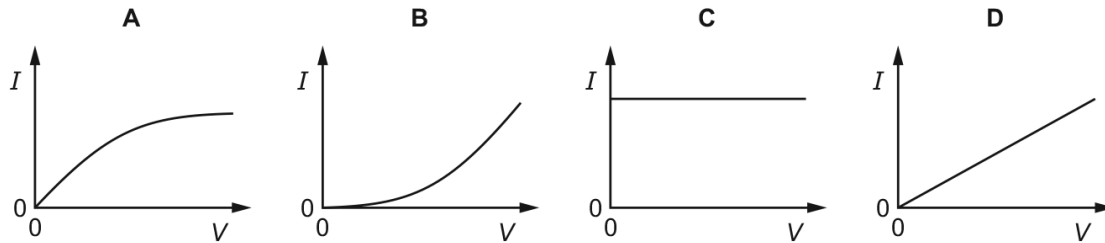

81. 0625\_s17\_qp\_22 Q: 33

The diagram shows an electric circuit.

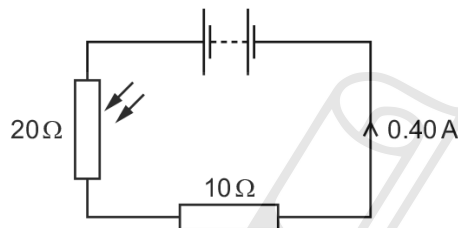

What is the potential difference (p.d.) across the LDR?

- A** 4.0V      **B** 8.0V      **C** 25V      **D** 50V

82. 0625\_s17\_qp\_23 Q: 27

Which material is a conductor of electricity?

- A** brass  
**B** glass  
**C** plastic  
**D** wood

83. 0625\_s17\_qp\_23 Q: 28

The diagrams each show a positive point charge.

Which diagram represents the pattern and the direction of the electric field due to the charge?

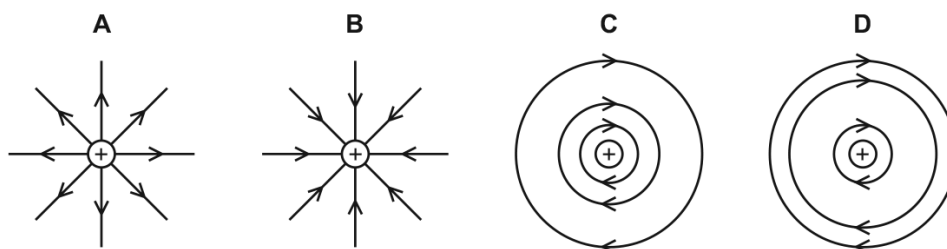

84. 0625\_s17\_qp\_23 Q: 29

Which quantity is equivalent to 1.0 V?

- A** 1.0 J/C      **B** 1.0 kJ/C      **C** 1.0 J/s      **D** 1.0 kJ/s

85. 0625\_s17\_qp\_23 Q: 30

A circuit contains a fixed resistor. The potential difference across the resistor is 24.0 V and the current in the resistor is 2.30 A.

How much energy is transferred in the resistor in a time of 17.0 minutes?

- A** 938 J      **B** 5630 J      **C** 56.3 kJ      **D** 9.38 kJ

86. 0625\_s17\_qp\_23 Q: 31

A battery, an ammeter, a switch, a lamp and a resistor are connected together in a circuit.

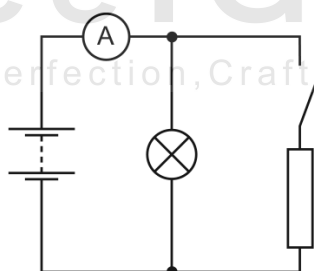

With the switch open, the ammeter reads 2.4 A. When the switch is closed, this reading increases to 4.0 A.

What is the current through the resistor with the switch closed?

- A** 0 A      **B** 1.6 A      **C** 3.2 A      **D** 6.4 A

## 4.2. ELECTRICAL QUANTITIES

87. 0625\_w17\_qp\_21 Q: 30

A positively-charged rod is held near to, but not touching, an uncharged metal sphere.

The sphere is briefly now connected to earth.

The rod is removed.

Which statement about the charge on the sphere is correct?

- A** It is charged negatively because negative charges have moved from earth to the sphere.
  - B** It is charged negatively because positive charges have moved from the sphere to earth.
  - C** It is charged positively because negative charges have moved from the sphere to earth.
  - D** It is charged positively because positive charges have moved to earth from the sphere.
- 

88. 0625\_w17\_qp\_21 Q: 31

The diagram shows a circuit with a gap between points P and Q.

Four pieces of metal wire of the same material are connected, in turn, between points P and Q in the circuit.

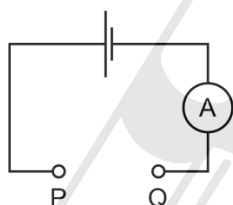

The table gives the diameters and lengths of the wires.

In which wire is the current the largest?

	diameter/mm	length/m
<b>A</b>	0.10	1.0
<b>B</b>	0.10	2.0
<b>C</b>	0.20	1.0
<b>D</b>	0.20	2.0

---

89. 0625\_w17\_qp\_21 Q: 32

A torch has a simple circuit with a 3.0 V battery and a lamp. There is a 20 mA current in the lamp.

How much energy is transferred to the lamp in 5.0 minutes?

- A** 0.30 J      **B** 18 J      **C** 60 J      **D** 0.30 kJ
-

90. 0625\_w17\_qp\_22 Q: 30

Which diagram represents the electric field due to a negatively-charged conducting sphere?

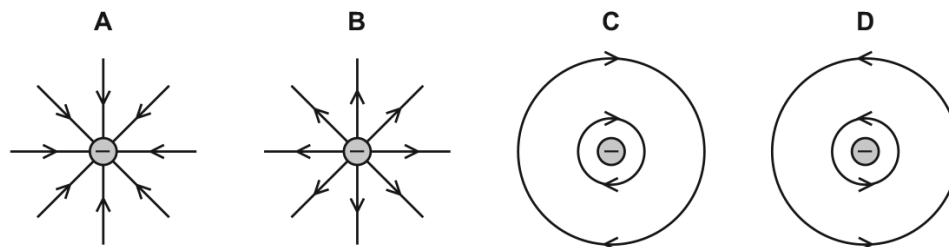

91. 0625\_w17\_qp\_22 Q: 31

The diagram shows a circuit with a gap between points P and Q.

Four pieces of metal wire of the same material are connected, in turn, between points P and Q in the circuit.

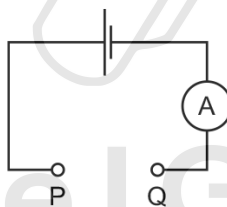

The table gives the diameters and lengths of the wires.

Paper Perfection, Crafted With Passion

In which wire is the current the largest?

	diameter/mm	length/m
<b>A</b>	0.10	1.0
<b>B</b>	0.10	2.0
<b>C</b>	0.20	1.0
<b>D</b>	0.20	2.0

4.2. ELECTRICAL QUANTITIES

92. 0625\_w17\_qp\_22 Q: 32

The graph shows the way in which one physical quantity  $y$  varies with another physical quantity  $x$ .

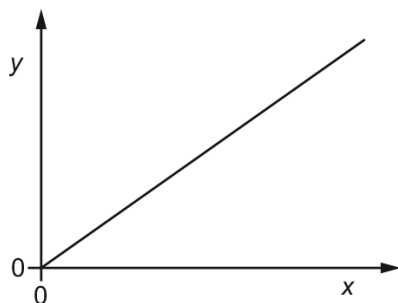

Which row gives suitable quantities for  $y$  and  $x$ ?

	$y$	$x$
<b>A</b>	the number of atoms of a radioactive isotope present	the time taken
<b>B</b>	the potential difference across a metallic conductor	the current in the metallic conductor
<b>C</b>	the resistance of a length of wire	the diameter of the wire
<b>D</b>	the volume of a 1.0 kg object	the density of the material from which the object is made

93. 0625\_w17\_qp\_22 Q: 33

The potential difference across a car headlamp is 12 V. The current in the lamp is 2.5 A.

How much energy is transferred by the lamp in 1.0 hour?

- A** 1800 J      **B** 1800 W      **C** 108 000 J      **D** 108 000 W

94. 0625\_w17\_qp\_22 Q: 30

There is a current in a metal wire.

Which particles in the wire move to cause this current?

- A**  $\alpha$ -particles  
**B** electrons  
**C** neutrons  
**D** protons

95. 0625\_m16\_qp\_22 Q: 28

Which produces an electromotive force (e.m.f.)?

- A a battery
- B a filament lamp
- C a resistor
- D a spring balance

96. 0625\_m16\_qp\_22 Q: 29

The table describes four different resistance wires. They are all made from the same metal.

Which wire has the smallest resistance?

	length of wire / m	diameter of wire / mm
<b>A</b>	2.0	1.0
<b>B</b>	2.0	1.5
<b>C</b>	3.0	1.0
<b>D</b>	3.0	1.5

97. 0625\_m16\_qp\_22 Q: 30

Which circuit shows the directions of the conventional current  $I$  and the flow of electrons?

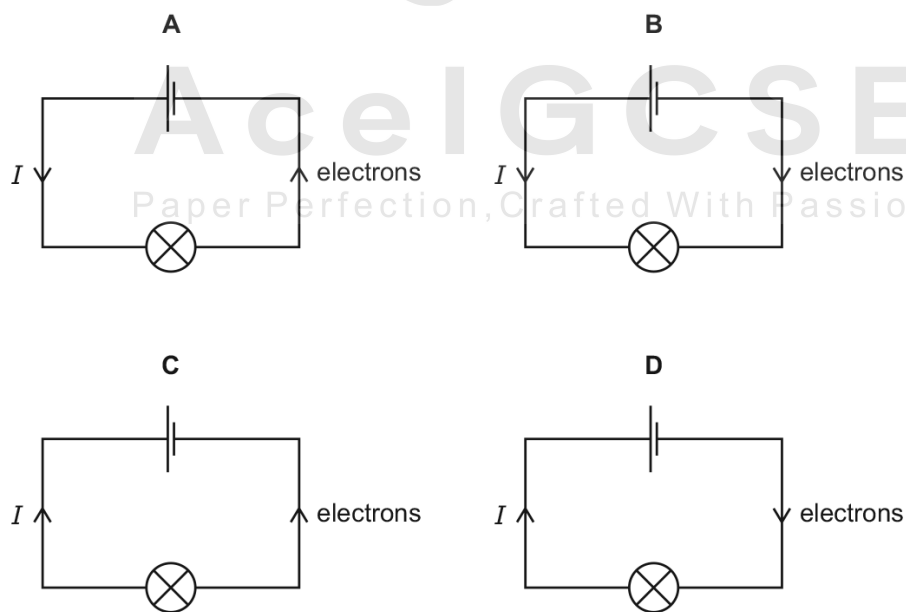

## 4.2. ELECTRICAL QUANTITIES

98. 0625\_p16\_qp\_20 Q: 30

The resistance of a wire depends on its length  $l$  and on its cross-sectional area  $A$ .

The resistance is

- A directly proportional to  $l$  and directly proportional to  $A$ .
  - B directly proportional to  $l$  and inversely proportional to  $A$ .
  - C inversely proportional to  $l$  and directly proportional to  $A$ .
  - D inversely proportional to  $l$  and inversely proportional to  $A$ .
- 

99. 0625\_p16\_qp\_20 Q: 31

In the circuit shown, the ammeter reads 2.0A and the voltmeter reads 12V.

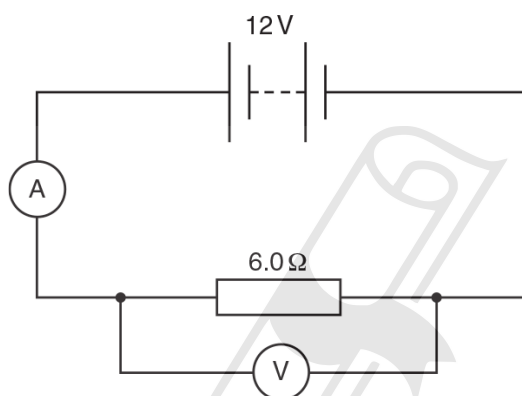

How much energy is transferred by the resistor in 10 seconds?

- A 2.4J
  - B 14.4J
  - C 240J
  - D 1440J
- 

100. 0625\_s16\_qp\_21 Q: 26

What is an electric field?

- A a region around a wire carrying an electric current in which a compass needle experiences a force
  - B a region in which an electric charge experiences a force
  - C a region in which an electric charge is attracted by the Earth's gravity
  - D a region through which electromagnetic radiation is passing
-

101. 0625\_s16\_qp\_21 Q: 27

A negatively charged rod is held close to one side of a metal sphere. The other side of the sphere is earthed.

Which diagram shows the distribution of charge on the metal sphere?

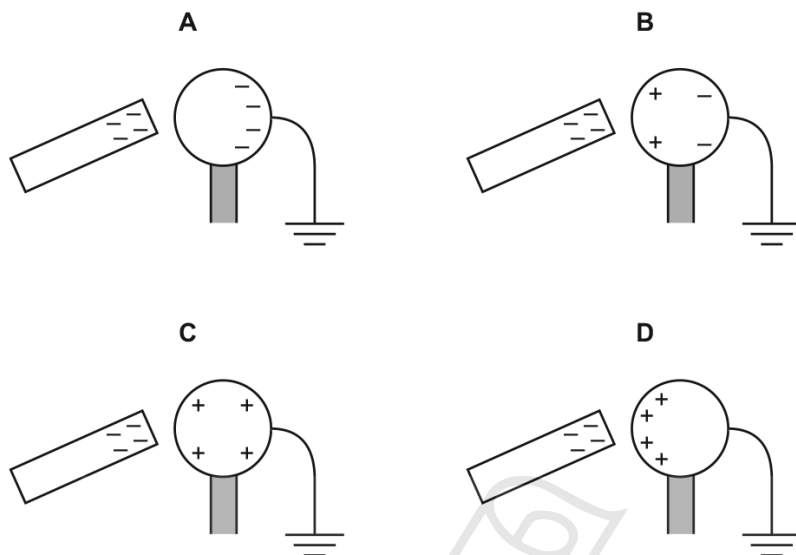

102. 0625\_s16\_qp\_21 Q: 28

A cell is connected to a lamp, as shown.

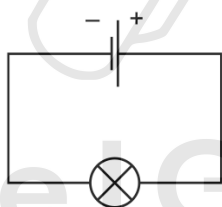

A charge of 4.0C flows through the lamp in 2.0s.

What is the direction of the electron flow in the lamp and what is the current in the lamp?

	direction of electron flow in lamp	current/A
<b>A</b>	from left to right	2.0
<b>B</b>	from left to right	8.0
<b>C</b>	from right to left	2.0
<b>D</b>	from right to left	8.0

4.2. ELECTRICAL QUANTITIES

103. 0625\_s16\_qp\_21 Q: 29

The diagrams show four current-voltage graphs.

Which two graphs show the characteristics of an ohmic resistor and of a filament lamp?

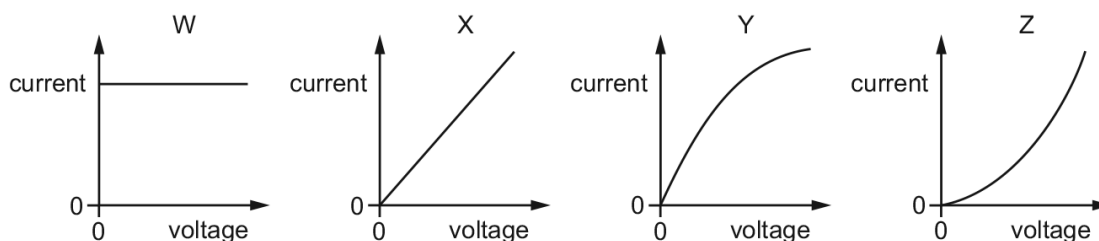

	ohmic resistor	filament lamp
<b>A</b>	W	Y
<b>B</b>	X	Y
<b>C</b>	W	Z
<b>D</b>	X	Z

104. 0625\_s16\_qp\_22 Q: 26

A small potential difference  $V$  is applied across a filament lamp. The current  $I$  in the lamp is measured.  $V$  is increased in stages and  $I$  is measured at each stage.

Which graph shows the results obtained?

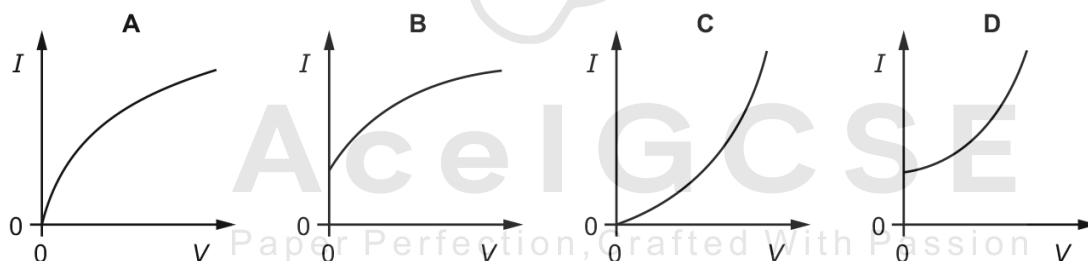

105. 0625\_s16\_qp\_22 Q: 27

A resistor of resistance  $R$  is connected to a battery of e.m.f.  $V$ .

There is a current  $I$  in the resistor.

Power  $P$  is dissipated by the resistor, and in time  $t$  the energy transferred is  $E$ .

Which expression is correct?

- A**  $E = IVt$       **B**  $E = Pit$       **C**  $P = VIR$       **D**  $P = \frac{V}{R}$

106. 0625\_s16\_qp\_22 Q: 28

A wire has a certain electrical resistance.

The diameter and length of the wire may be changed.

Which pair of changes **must** cause the resistance of the wire to increase?

	change of diameter	change of length
<b>A</b>	decrease	decrease
<b>B</b>	decrease	increase
<b>C</b>	increase	decrease
<b>D</b>	increase	increase

107. 0625\_s16\_qp\_23 Q: 27

Each diagram shows two charged metal plates.

Which diagram shows the pattern and the direction of the electric field between the plates?

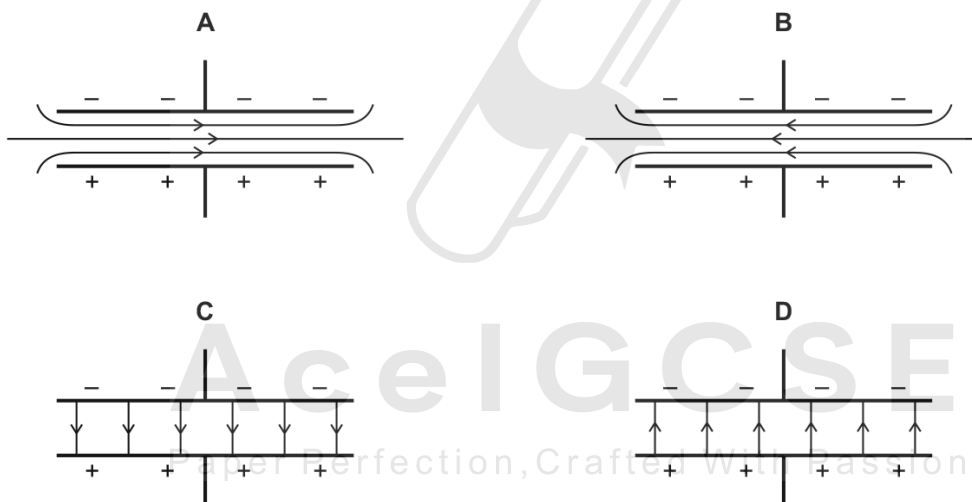

4.2. ELECTRICAL QUANTITIES

108. 0625\_w16\_qp\_21 Q: 29

A polythene rod is rubbed with a cloth. The rod becomes positively charged because of the movement of charged particles.

Which row gives the name of these charged particles, and the direction in which they move?

	charged particles	direction of movement
<b>A</b>	electrons	from cloth to rod
<b>B</b>	electrons	from rod to cloth
<b>C</b>	protons	from cloth to rod
<b>D</b>	protons	from rod to cloth

109. 0625\_w16\_qp\_21 Q: 32

The circuit shows a 12V battery connected to a lamp of resistance  $3.0\ \Omega$ .

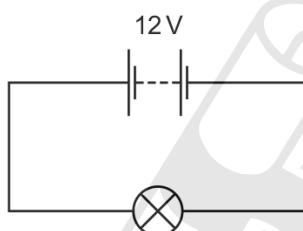

How much energy is transferred to the surroundings by the lamp in 2.0 minutes?

- A** 48 J      **B** 96 J      **C** 2880 J      **D** 5760 J

110. 0625\_w16\_qp\_22 Q: 30

The diagram shows a circuit.

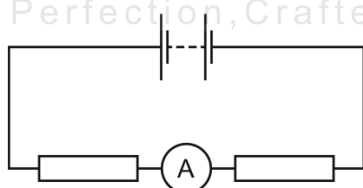

The reading on the ammeter is 12 A.

How much charge passes through the ammeter in 2.0 minutes?

- A** 0.10 C      **B** 6.0 C      **C** 24 C      **D** 1440 C

111. 0625\_w16\_qp\_22 Q: 31

A copper wire has a resistance of  $2.0\Omega$ .

A second copper wire is twice as long as the first wire, and its diameter is twice the diameter of the first wire.

What is the resistance of the second wire?

- A  $1.0\Omega$       B  $2.0\Omega$       C  $8.0\Omega$       D  $16.0\Omega$

112. 0625\_w16\_qp\_22 Q: 33

In the circuit shown, the voltmeter reads  $2.0\text{V}$ . A charge of  $5.0\text{C}$  passes through the resistor in a certain time.

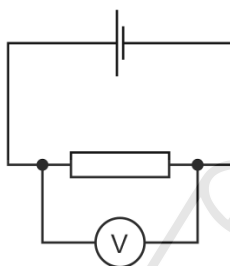

How much energy is supplied to the resistor in this time?

- A  $0.40\text{J}$       B  $2.5\text{J}$       C  $10\text{J}$       D  $20\text{J}$

113. 0625\_w16\_qp\_23 Q: 28

A student holds a rod in his hand.

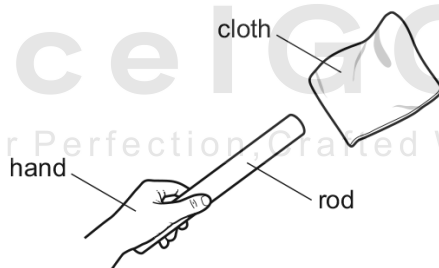

He rubs the rod with a cloth. The rod gains a positive charge.

Of which material could the rod be made, and which transfer of charge has happened?

	material of rod	transfer of charge
<b>A</b>	metal	negative charge from rod to cloth
<b>B</b>	metal	positive charge from cloth to rod
<b>C</b>	plastic	negative charge from rod to cloth
<b>D</b>	plastic	positive charge from cloth to rod

4.2. ELECTRICAL QUANTITIES

114. 0625\_w16\_qp\_23 Q: 30

The graph shows the relationship between the current in a circuit component and the potential difference (p.d.) across it. The graph has a straight section and a curved section.

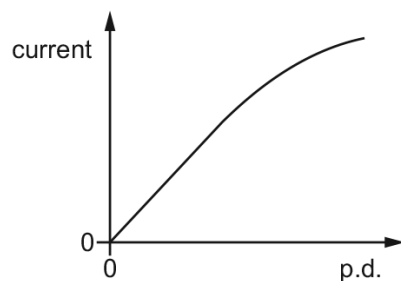

What happens to the resistance of the component in these two sections as the current increases?

	straight section	curved section
<b>A</b>	resistance increases	resistance decreases
<b>B</b>	resistance increases	resistance increases
<b>C</b>	no change in resistance	resistance decreases
<b>D</b>	no change in resistance	resistance increases

115. 0625\_w16\_qp\_23 Q: 31

In the circuit shown there is a current of 10 A.

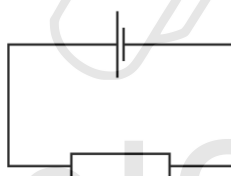

How much charge passes through the resistor in 2.0 minutes?

- A** 0.083C      **B** 5C      **C** 20C      **D** 1200C

116. 0625\_m15\_qp\_12 Q: 27

A teacher wishes to show the production of electrostatic charges.

She holds a rod and rubs it with a cotton cloth. A copper rod, a glass rod, a plastic rod and a steel rod are available.

Which two rods would both be suitable to use?

- A** a copper rod and a glass rod
  - B** a glass rod and a plastic rod
  - C** a plastic rod and a copper rod
  - D** a plastic rod and a steel rod
- 



**Ace | GCSE**  
Paper Perfection, Crafted With Passion

4.2. ELECTRICAL QUANTITIES

117. 0625\_m15\_qp\_12 Q: 29

A battery is connected to two crocodile clips and a lamp.

There is a gap between the crocodile clips.

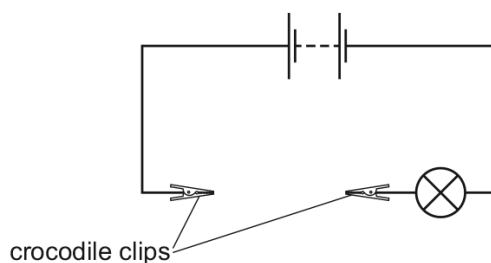

Four cylinders W, X, Y and Z are made of the same metal but have different dimensions. The cylinders are connected in turn, by their ends, between the crocodile clips. The diagrams of the cylinders are all drawn to the same scale.

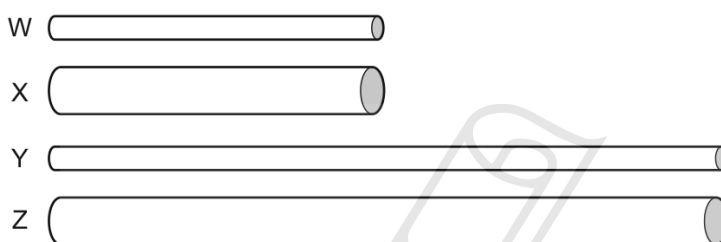

Which cylinder makes the lamp glow most brightly and which cylinder makes the lamp glow least brightly?

	most brightly	least brightly
<b>A</b>	W	Y
<b>B</b>	W	Z
<b>C</b>	X	Y
<b>D</b>	X	Z

Ace IGCSE  
Paper Perfection, Crafted With Passion

118. 0625\_s15\_qp\_11 Q: 27

The diagram shows a piece of metal resistance wire.



Which wire, made of the same metal, has a smaller resistance?

- A** a wire of the same length with a larger diameter
- B** a wire of the same length with a smaller diameter
- C** a wire of greater length with the same diameter
- D** a wire of greater length with a smaller diameter

119. 0625\_s15\_qp\_11 Q: 28

What is the unit of electromotive force (e.m.f.)?

- A ampere
  - B joule
  - C volt
  - D watt
- 

120. 0625\_s15\_qp\_12 Q: 27

A student has wires of different lengths and different diameters. The wires are all made of the same metal.

The student measures the resistance of one wire.

Which wire has a greater resistance than the wire he has measured?

- A a shorter wire with a larger diameter
  - B a shorter wire with the same diameter
  - C a wire of the same length with a larger diameter
  - D a wire of the same length with a smaller diameter
-

4.2. ELECTRICAL QUANTITIES

121. 0625\_s15\_qp\_12 Q: 29

Diagram 1 shows two thin, uncharged strips of plastic.

Diagram 2 shows the same strips after they have been rubbed with a dry cloth.

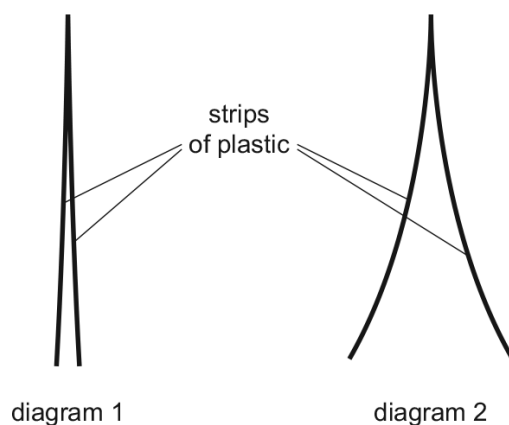

Which row describes the charge on the strips after rubbing, and the force between the strips after rubbing?

	charge on strips	force between strips
<b>A</b>	opposite	attraction
<b>B</b>	opposite	repulsion
<b>C</b>	the same	attraction
<b>D</b>	the same	repulsion

122. 0625\_s15\_qp\_1Q: 27

What is the unit of electromotive force (e.m.f.)?

- A** ampere
- B** newton
- C** ohm
- D** volt

123. 0625\_s15\_qp\_13 Q: 28

Which sample of copper wire has the greatest electrical resistance?

	length of wire / m	diameter of wire / mm
<b>A</b>	1.0	2.0
<b>B</b>	1.0	4.0
<b>C</b>	10	2.0
<b>D</b>	10	4.0

124. 0625\_w15\_qp\_11 Q: 27

What is the unit of electrical power?

- A** ampere
- B** joule
- C** volt
- D** watt

125. 0625\_w15\_qp\_11 Q: 28

Some resistors are made using one type of wire. Two different lengths of wire are available. Each length is available in two different diameters.

Which wire has the highest resistance?

- A** the wire with the greater length and the larger diameter
- B** the wire with the greater length and the smaller diameter
- C** the wire with the smaller length and the larger diameter
- D** the wire with the smaller length and the smaller diameter

4.2. ELECTRICAL QUANTITIES

126. 0625\_w15\_qp\_11 Q: 29

Four students are each given an identical resistor and asked to find its resistance. They each measure the potential difference across the resistor and the current in it.

One student makes a mistake.

Which row shows the results of the student that makes a mistake?

	potential difference/V	current/A
<b>A</b>	1.2	0.500
<b>B</b>	2.4	1.100
<b>C</b>	1.5	0.625
<b>D</b>	3.0	1.250

127. 0625\_w15\_qp\_12 Q: 27

Two plastic rods P and Q are both negatively charged. Rod P hangs freely.

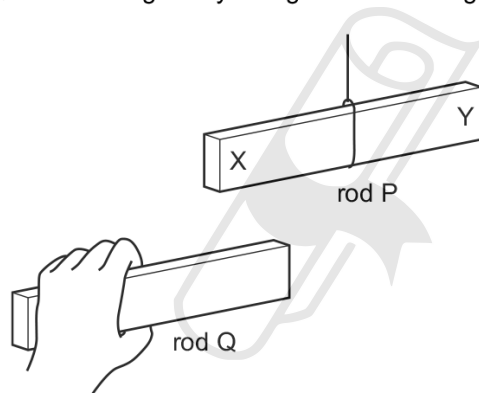

The end of rod Q is brought near to end X of rod P, and then near to end Y of rod P.

What happens to the rods in each position?

	near end X	near end Y
<b>A</b>	they attract	they attract
<b>B</b>	they attract	they repel
<b>C</b>	they repel	they attract
<b>D</b>	they repel	they repel

128. 0625\_w15\_qp\_12 Q: 29

A student has four pieces of resistance wire made of the same material. Each piece is connected in turn between the terminals X and Y in the circuit.

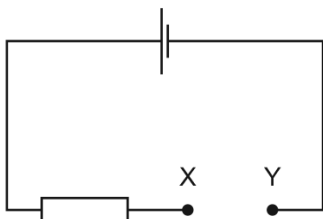

In which wire is the current the largest?

	length of wire / m	diameter of wire / mm
<b>A</b>	0.5	0.5
<b>B</b>	0.5	1.0
<b>C</b>	1.0	0.5
<b>D</b>	1.0	1.0

129. 0625\_w15\_qp\_13 Q: 27

A plastic rod is rubbed with a cotton cloth. This process causes the rod and the cloth to become charged. These charges cause a force between the rod and the cloth.

Which row compares the charges on the rod and the cloth, and describes the effect of the force between the rod and the cloth?

	charges on rod and cloth	effect
<b>A</b>	opposite	they attract
<b>B</b>	opposite	they repel
<b>C</b>	the same	they attract
<b>D</b>	the same	they repel

4.2. ELECTRICAL QUANTITIES

130. 0625\_w15\_qp\_13 Q: 28

A metal wire of circular cross-section has diameter  $d$  and length  $l$ .

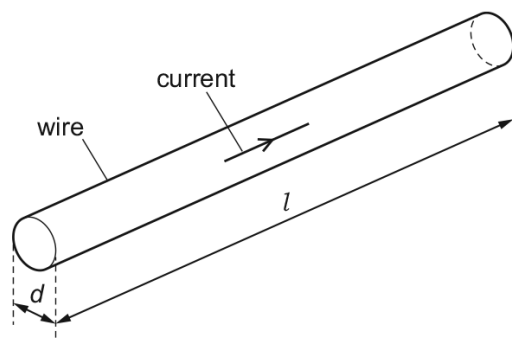

Which pair of changes, if both are carried out, **must** increase the resistance of the wire?

- A decrease  $l$  and decrease  $d$
- B decrease  $l$  and increase  $d$
- C increase  $l$  and decrease  $d$
- D increase  $l$  and increase  $d$

---

131. 0625\_s14\_qp\_11 Q: 27

A plastic rod and a dry cloth are uncharged.

The rod is now rubbed with the cloth and they both become charged. The rod becomes negatively charged because some charged particles move from the cloth to the rod.

What is the charge on the cloth and which particles moved in the charging process?

	charge on cloth	particles that moved
A	negative	electrons
B	negative	neutrons
C	positive	electrons
D	positive	neutrons

132. 0625\_s14\_qp\_11 Q: 28

The diagram shows an incomplete circuit.

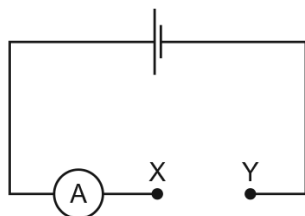

Four wires of different length and thickness are connected in turn between point X and point Y. All four wires are made of the same metal.

Which wire will cause the greatest reading on the ammeter?

- A long and thick
- B long and thin
- C short and thick
- D short and thin

133. 0625\_s14\_qp\_12 Q: 28

Two balloons, X and Y, are suspended by insulating threads. They are each held near a negatively charged balloon. The balloons hang as shown.

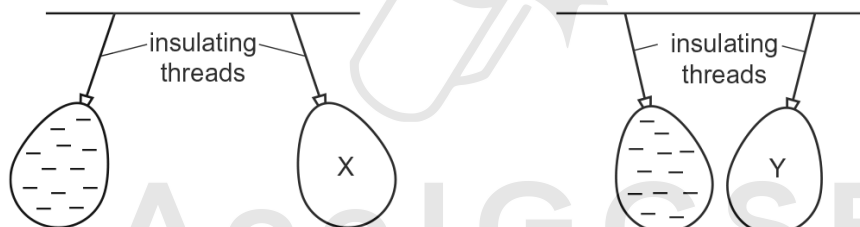

What is the charge on balloon X and what is the charge on balloon Y?

	balloon X	balloon Y
<b>A</b>	negative	negative
<b>B</b>	negative	positive
<b>C</b>	positive	negative
<b>D</b>	positive	positive

## 4.2. ELECTRICAL QUANTITIES

134. 0625\_s14\_qp\_12 Q: 29

Which quantities is a voltmeter used to measure?

- A** current and e.m.f. only
  - B** current and p.d. only
  - C** e.m.f. and p.d. only
  - D** e.m.f., current and p.d
- 

135. 0625\_w14\_qp\_11 Q: 28

Which row gives the unit for energy and the unit for electromotive force (e.m.f.)?

	energy	e.m.f.
<b>A</b>	J	N
<b>B</b>	J	V
<b>C</b>	W	N
<b>D</b>	W	V

---

136. 0625\_w14\_qp\_13 Q: 28

Four wires are made from the same material.

Which wire has the least resistance?

	diameter of wire / mm	length of wire / cm
<b>A</b>	0.2	100
<b>B</b>	0.2	200
<b>C</b>	0.4	100
<b>D</b>	0.4	200

---

137. 0625\_s13\_qp\_11 Q: 28

Three charged balls, P, Q and R are suspended by insulating threads. Ball P is negatively charged.

Ball Q is brought close to ball P.

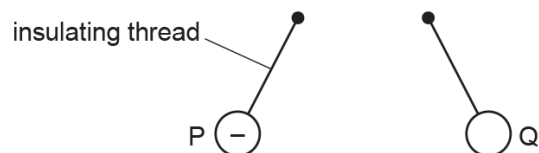

Ball Q is now brought close to ball R.

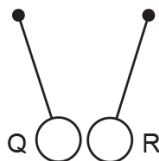

What are the charges on ball Q and on ball R?

	ball Q	ball R
<b>A</b>	positive	positive
<b>B</b>	positive	negative
<b>C</b>	negative	positive
<b>D</b>	negative	negative

138. 0625\_s13\_qp\_11 Q: 30

Which copper wire would have the smallest resistance?

- A** a long, thick wire
- B** a long, thin wire
- C** a short, thick wire
- D** a short, thin wire

139. 0625\_s13\_qp\_12 Q: 29

Which group contains only good electrical conductors?

- A** air, carbon (graphite), plastic
- B** air, gold, mercury
- C** carbon (graphite), copper, mercury
- D** copper, gold, plastic

4.2. ELECTRICAL QUANTITIES

140. 0625\_w13\_qp\_11 Q: 28

Which equation can be used to calculate the resistance  $R$  of a resistor?

- A**  $V = I \div R$       **B**  $I = V \times R$       **C**  $R = V \times I$       **D**  $V = I \times R$

141. 0625\_w13\_qp\_11 Q: 30

Two similar balloons hang side by side, on insulating threads, a short distance apart. They are both rubbed with the same dry cloth and become charged.

Which diagram shows how the balloons hang after charging?

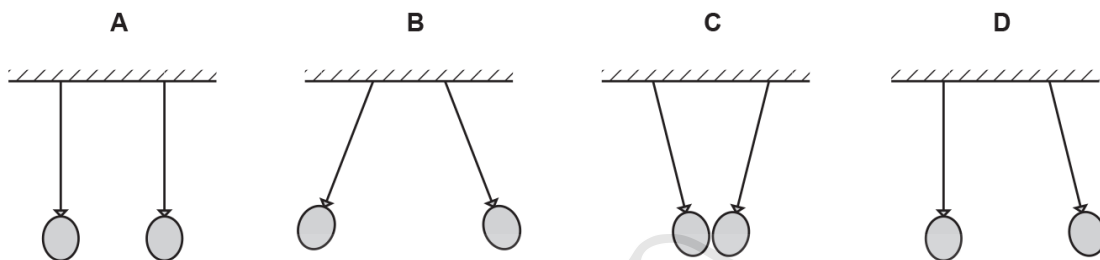

142. 0625\_w13\_qp\_13 Q: 28

A negatively charged plastic rod P is placed above a positively charged plastic rod Q.

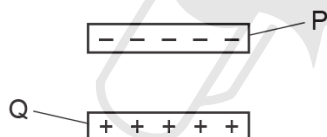

What are the directions of the electrostatic forces on rod P and on rod Q?

	electrostatic force on rod P	electrostatic force on rod Q
<b>A</b>	downwards	downwards
<b>B</b>	downwards	upwards
<b>C</b>	upwards	downwards
<b>D</b>	upwards	upwards

143. 0625\_w13\_qp\_13 Q: 32

The diagram shows a circuit.

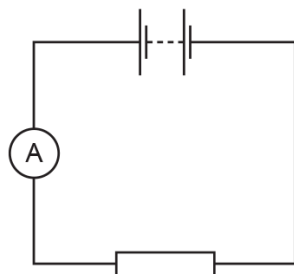

What should be increased to increase the current in the circuit?

- A the e.m.f. of the battery
- B the length of the connecting wires
- C the resistance of the resistor
- D the temperature of the resistor

144. 0625\_w13\_qp\_13 Q: 34

An electric motor is connected to the mains supply by insulated wires. The circuit is protected by a fuse, but the connecting wires become hot.

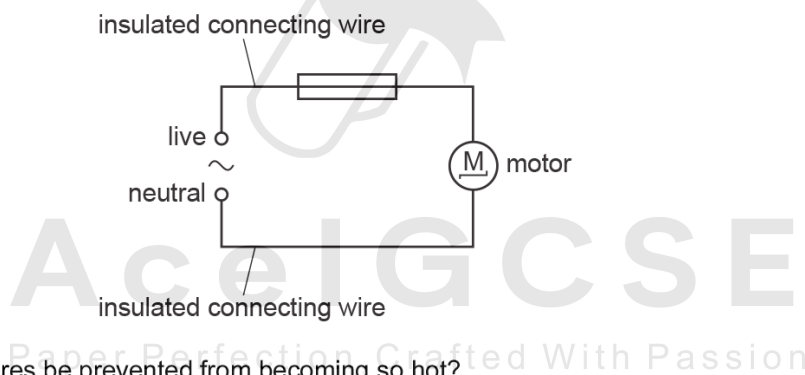

How could the wires be prevented from becoming so hot?

- A Connect a second fuse in the neutral wire.
- B Use a fuse with a higher current rating.
- C Use thicker connecting wires.
- D Use thicker insulation on the connecting wires.

## 4.2. ELECTRICAL QUANTITIES

145. 0625\_s12\_qp\_11 Q: 29

In which unit is potential difference measured?

- A ampere
  - B ohm
  - C volt
  - D watt
- 

146. 0625\_s12\_qp\_11 Q: 30

The circuit shown in the diagram contains an unknown component X, hidden in a box.

The voltage-current graph for X is as shown.

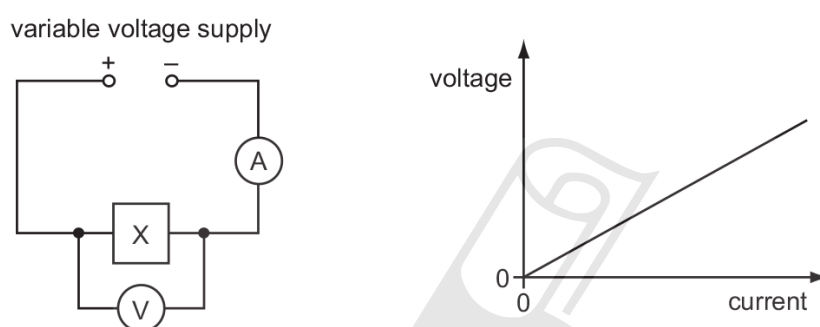

What is the component X?

- A a capacitor
  - B a closed switch
  - C an open switch
  - D a resistor of constant resistance
- 

147. 0625\_s12\_qp\_12 Q: 29

In which unit is potential difference measured?

- A ampere
  - B ohm
  - C volt
  - D watt
-

148. 0625\_w12\_qp\_11 Q: 29

Which of these is an electric current?

- A a beam of atoms
- B a beam of electrons
- C a beam of molecules
- D a beam of neutrons

149. 0625\_w12\_qp\_11 Q: 33

The diagram shows two voltmeters, P and Q, connected to a potential divider.

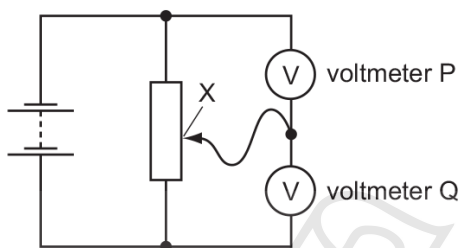

The sliding connection at point X is moved towards the top of the diagram.

What happens to the reading on P and to the reading on Q?

	reading on P	reading on Q
<b>A</b>	decreases	decreases
<b>B</b>	decreases	increases
<b>C</b>	increases	decreases
<b>D</b>	increases	increases

150. 0625\_w12\_qp\_11 Q: 34

An electric oven is connected to the mains supply using insulated copper wires. The wires become very warm.

What can be done to prevent so much heat being produced in the connecting wires?

- A Use thicker copper wires.
- B Use thinner copper wires.
- C Use thicker insulation.
- D Use thinner insulation.

## 4.2. ELECTRICAL QUANTITIES

151. 0625\_w12\_qp\_12 Q: 27

Which of these is an electric current?

- A** a beam of atoms
  - B** a beam of electrons
  - C** a beam of molecules
  - D** a beam of neutrons
- 

152. 0625\_w12\_qp\_12 Q: 36

An electric oven is connected to the mains supply using insulated copper wires. The wires become very warm.

What can be done to prevent so much heat being produced in the connecting wires?

- A** Use thicker copper wires.
  - B** Use thinner copper wires.
  - C** Use thicker insulation.
  - D** Use thinner insulation.
- 

153. 0625\_w12\_qp\_13 Q: 29

Which is the worst electrical conductor?

- A** aluminium
  - B** carbon (graphite)
  - C** iron
  - D** sulfur
- 

  
**AceIGCSE**

Paper Perfection, Crafted With Passion

---

154. 0625\_w12\_qp\_13 Q: 34

An electric oven is connected to the mains supply using insulated copper wires. The wires become very warm.

What can be done to prevent so much heat being produced in the connecting wires?

- A** Use thicker copper wires.
  - B** Use thinner copper wires.
  - C** Use thicker insulation.
  - D** Use thinner insulation.
-

SN	Paper	Q. No.	Answer
01	0625_m22_qp_22	27	D
02	0625_m22_qp_22	28	D
03	0625_m22_qp_22	29	A
04	0625_m21_qp_22	30	C
05	0625_m21_qp_22	31	B
06	0625_m21_qp_22	32	D
07	0625_s21_qp_21	29	C
08	0625_s21_qp_21	30	D
09	0625_s21_qp_21	31	B
10	0625_s21_qp_22	30	C
11	0625_s21_qp_23	31	C
12	0625_w21_qp_21	25	B
13	0625_w21_qp_21	26	B
14	0625_w21_qp_21	27	C
15	0625_w21_qp_22	25	A
16	0625_w21_qp_22	26	A
17	0625_w21_qp_22	27	B
18	0625_w21_qp_22	29	D
19	0625_w21_qp_23	25	D
20	0625_w21_qp_23	26	C
21	0625_w21_qp_23	27	A
22	0625_w21_qp_23	29	D
23	0625_w21_qp_23	34	D
24	0625_m20_qp_22	30	C
25	0625_m20_qp_22	31	B
26	0625_p20_qp_20	29	B
27	0625_p20_qp_20	30	B
28	0625_p20_qp_20	31	C
29	0625_s20_qp_21	29	C
30	0625_s20_qp_22	28	B
31	0625_s20_qp_22	30	C
32	0625_s20_qp_23	28	A
33	0625_s20_qp_23	30	D
34	0625_s20_qp_23	35	B
35	0625_w20_qp_21	29	A
36	0625_w20_qp_21	30	C
37	0625_w20_qp_21	31	A
38	0625_w20_qp_22	30	B
39	0625_w20_qp_22	31	C
40	0625_w20_qp_23	29	A
41	0625_w20_qp_23	30	A
42	0625_m19_qp_22	29	B
43	0625_m19_qp_22	30	B
44	0625_s19_qp_21	27	C
45	0625_s19_qp_21	28	C
46	0625_s19_qp_21	29	B
47	0625_s19_qp_22	29	A
48	0625_s19_qp_23	29	C
49	0625_w19_qp_21	27	C

SN	Paper	Q. No.	Answer
50	0625_w19_qp_21	28	D
51	0625_w19_qp_22	29	A
52	0625_w19_qp_23	28	D
53	0625_m18_qp_22	30	A
54	0625_m18_qp_22	31	B
55	0625_m18_qp_22	32	D
56	0625_s18_qp_21	27	C
57	0625_s18_qp_21	28	C
58	0625_s18_qp_21	29	D
59	0625_s18_qp_22	27	B
60	0625_s18_qp_22	29	D
61	0625_s18_qp_23	27	D
62	0625_s18_qp_23	29	C
63	0625_w18_qp_21	28	A
64	0625_w18_qp_21	30	D
65	0625_w18_qp_22	27	A
66	0625_w18_qp_22	29	D
67	0625_w18_qp_23	28	D
68	0625_w18_qp_23	29	C
69	0625_w18_qp_23	31	C
70	0625_m17_qp_22	27	A
71	0625_m17_qp_22	28	C
72	0625_m17_qp_22	29	A
73	0625_s17_qp_21	27	C
74	0625_s17_qp_21	28	A
75	0625_s17_qp_21	29	D
76	0625_s17_qp_21	30	C
77	0625_s17_qp_22	27	A
78	0625_s17_qp_22	28	B
79	0625_s17_qp_22	29	D
80	0625_s17_qp_22	30	D
81	0625_s17_qp_22	33	B
82	0625_s17_qp_23	27	A
83	0625_s17_qp_23	28	A
84	0625_s17_qp_23	29	A
85	0625_s17_qp_23	30	C
86	0625_s17_qp_23	31	B
87	0625_w17_qp_21	30	A
88	0625_w17_qp_21	31	C
89	0625_w17_qp_21	32	B
90	0625_w17_qp_22	30	A
91	0625_w17_qp_22	31	C
92	0625_w17_qp_22	32	B
93	0625_w17_qp_22	33	C
94	0625_w17_qp_23	30	B
95	0625_m16_qp_22	28	A
96	0625_m16_qp_22	29	B
97	0625_m16_qp_22	30	B
98	0625_p16_qp_20	30	B

SN	Paper	Q. No.	Answer
99	0625_p16_qp_20	31	C
100	0625_s16_qp_21	26	B
101	0625_s16_qp_21	27	D
102	0625_s16_qp_21	28	A
103	0625_s16_qp_21	29	B
104	0625_s16_qp_22	26	A
105	0625_s16_qp_22	27	A
106	0625_s16_qp_22	28	B
107	0625_s16_qp_23	27	D
108	0625_w16_qp_21	29	B
109	0625_w16_qp_21	32	D
110	0625_w16_qp_22	30	D
111	0625_w16_qp_22	31	A
112	0625_w16_qp_22	33	C
113	0625_w16_qp_23	28	C
114	0625_w16_qp_23	30	D
115	0625_w16_qp_23	31	D
116	0625_m15_qp_12	27	B
117	0625_m15_qp_12	29	C
118	0625_s15_qp_11	27	A
119	0625_s15_qp_11	28	C
120	0625_s15_qp_12	27	D
121	0625_s15_qp_12	29	D
122	0625_s15_qp_13	27	D
123	0625_s15_qp_13	28	C
124	0625_w15_qp_11	27	D
125	0625_w15_qp_11	28	B
126	0625_w15_qp_11	29	B
127	0625_w15_qp_12	27	D
128	0625_w15_qp_12	29	B
129	0625_w15_qp_13	27	A
130	0625_w15_qp_13	28	C
131	0625_s14_qp_11	27	C
132	0625_s14_qp_11	28	C
133	0625_s14_qp_12	28	B
134	0625_s14_qp_12	29	C
135	0625_w14_qp_11	28	B
136	0625_w14_qp_13	28	C
137	0625_s13_qp_11	28	C
138	0625_s13_qp_11	30	C
139	0625_s13_qp_12	29	C
140	0625_w13_qp_11	28	D
141	0625_w13_qp_11	30	B
142	0625_w13_qp_13	28	B
143	0625_w13_qp_13	32	A
144	0625_w13_qp_13	34	C
145	0625_s12_qp_11	29	C
146	0625_s12_qp_11	30	D
147	0625_s12_qp_12	29	C

SN	Paper	Q. No.	Answer
148	0625_w12_qp_11	29	B
149	0625_w12_qp_11	33	B
150	0625_w12_qp_11	34	A
151	0625_w12_qp_12	27	B
152	0625_w12_qp_12	36	A
153	0625_w12_qp_13	29	D
154	0625_w12_qp_13	34	A