

3.4. SOUND

01. 0625_s12_qp_12 Q: 22

The diagram shows radiation from a lamp passing through a prism.

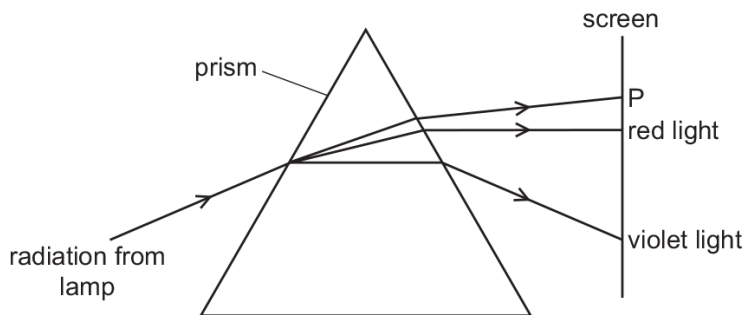

Which type of radiation is found at P?

- A γ -rays
- B infra-red
- C ultraviolet
- D X-rays

02. 0625_w12_qp_13 Q: 22

Which statement about radio waves is correct?

- A They travel as longitudinal waves.
- B They travel at the same speed as sound waves.
- C They travel by means of molecular vibration.
- D They can travel through a vacuum.

AcelGCSE
Paper Perfection, Crafted With Passion

3.4 Sound

03. 0625_m22_qp_22 Q: 26

The diagram shows air particles in a sound wave.



Which row correctly identifies the position of a compression and position of a rarefaction?

	compression	rarefaction
A	X	Y
B	Y	X
C	V	Z
D	Z	V

04. 0625_m21_qp_22 Q: 20

What is the approximate wavelength in air of the highest frequency sound that can be heard by a normal healthy person?

- A** 0.02m **B** 60m **C** 20000m **D** 7000000m

05. 0625_m21_qp_22 Q: 26

The diagram represents a sound wave.

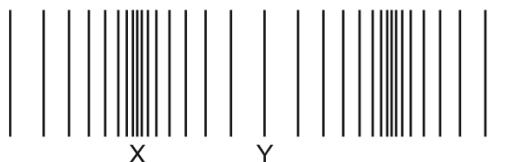

What are the names of the parts of the sound wave labelled X and Y?

	X	Y
A	amplitude	wavelength
B	compression	rarefaction
C	rarefaction	amplitude
D	wavelength	compression

06. 0625_m21_qp_22 Q: 27

The speed of sound is different in different states of matter.

The speed of sound in liquid water is 1500 m/s.

Which row correctly compares the speed of sound in ice and the speed of sound in water vapour with the speed of sound in water?

	<u>speed of sound in ice</u> m/s	<u>speed of sound in steam</u> m/s
A	less than 1500	less than 1500
B	less than 1500	more than 1500
C	more than 1500	less than 1500
D	more than 1500	more than 1500

3.4. SOUND

07.0625_s21_qp_21 Q:26

A sound wave is travelling outwards from a loudspeaker into the surrounding air.

Here are three statements.

- 1 The air pressure is lower at a rarefaction compared with undisturbed air.
- 2 The density of the air is less at a compression compared with undisturbed air.
- 3 The distance from a compression to a rarefaction equals half a wavelength.

Which statements about the sound wave are correct?

- A** 1 and 2 only **B** 1 and 3 only **C** 2 and 3 only **D** 1, 2 and 3
-

08.0625_s21_qp_21 Q:27

The sound from a loudspeaker must pass through two materials to reach a microphone.

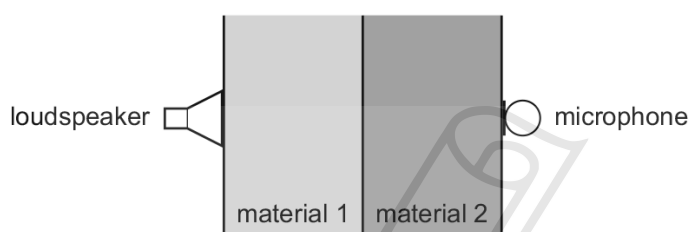

Which combination of materials gives the shortest time for the sound to reach the microphone?

	material 1	material 2
A	air	hydrogen
B	air	water
C	copper	aluminium
D	water	oil

09.0625_s21_qp_23 Q:26

The diagram shows a model of a sound wave passing through air in an open tube.

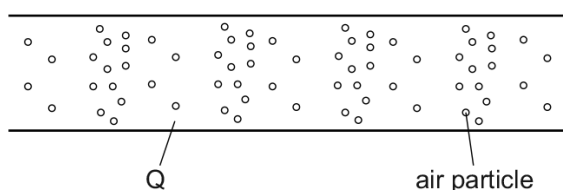

What is the region Q?

- A** a compression which is a region of high pressure
 - B** a compression which is a region of low pressure
 - C** a rarefaction which is a region of high pressure
 - D** a rarefaction which is a region of low pressure
-

10. 0625_s21_qp_23 Q:27

The sound from a loudspeaker must pass through two materials to reach a microphone.

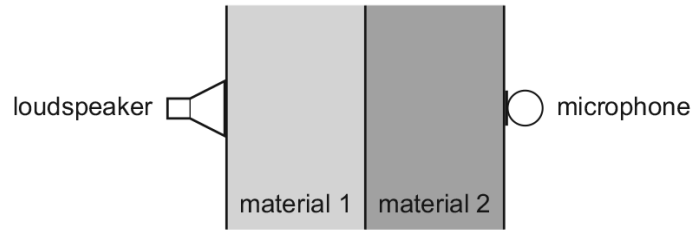

Which combination of materials gives the shortest time for the sound to reach the microphone?

	material 1	material 2
A	air	hydrogen
B	air	water
C	copper	aluminium
D	water	oil

11. 0625_w21_qp_21 Q:24

What is ultrasound?

- A** sound waves that are so loud that they damage human hearing
- B** sound waves that are too high-pitched for humans to hear
- C** sound waves that are too low-pitched for humans to hear
- D** sound waves that are too quiet for humans to hear

3.4. SOUND

12. 0625_w21_qp_23 Q: 17

In the diagram, the mountaineer can hear the stream although he cannot see it. When he is closer to the gully, he can both hear and see the stream. When he is further from the gully, he can neither hear nor see the stream.

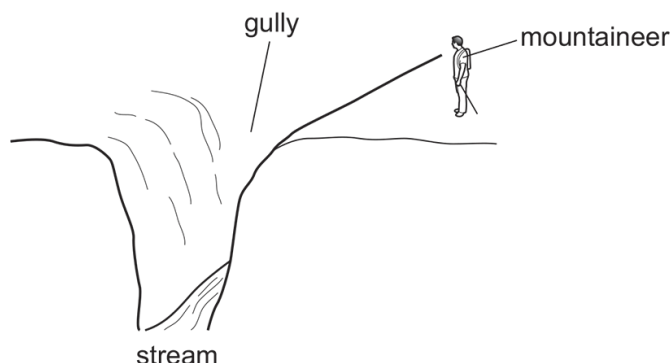

Which statement is **not** correct?

- A As he approaches the gully edge, he hears first the short wavelength, higher frequencies and then the long wavelength, lower frequencies.
- B As he approaches the gully edge, the sound becomes louder.
- C He hears the stream because some of the sound is diffracted.
- D He hears the stream because some of the sound is reflected from the opposite wall of the gully.

13. 0625_w21_qp_23 Q: 23

Which row gives the typical values of the speed of sound at room temperature in the materials stated?

	speed of sound m/s		
	air	water	iron
A	340	1500	5100
B	340	5100	1500
C	5100	1500	340
D	3.0×10^8	3.0×10^8	3.0×10^8

14. 0625_w21_qp_23 Q:24

What is ultrasound?

- A sound waves that are so loud that they damage human hearing
- B sound waves that are too high-pitched for humans to hear
- C sound waves that are too low-pitched for humans to hear
- D sound waves that are too quiet for humans to hear

15. 0625_m20_qp_22 Q:28

The diagram shows compressions and rarefactions in air as a sound wave moves from left to right.

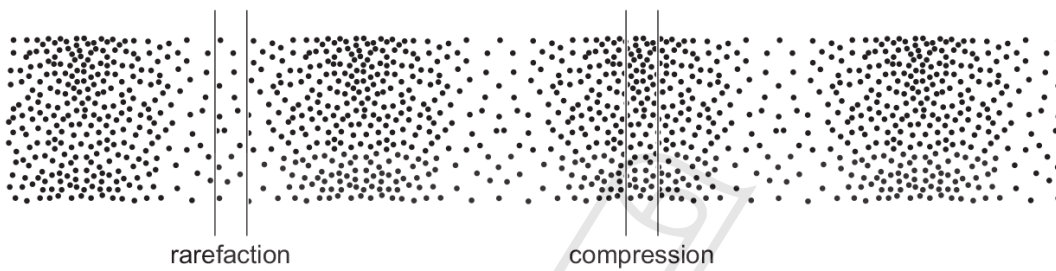

A quieter sound of the same frequency is made.

What will happen to the number of particles in a region of rarefaction and in a region of compression?

	number of particles in region of rarefaction	number of particles in region of compression
A	decrease	decrease
B	decrease	increase
C	increase	decrease
D	increase	increase

3.4. SOUND

16. 0625_p20_qp_20 Q:27

An echo-sounder on a ship produces a pulse of sound. The echo is received by the echo-sounder after two seconds.

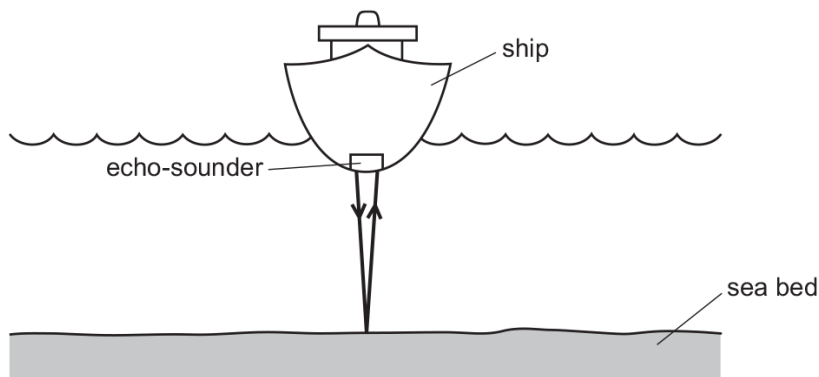

The speed of sound in sea-water is 1500 m/s.

What is the depth of the sea-water below the ship?

- A** 750 m **B** 1500 m **C** 3000 m **D** 6000 m
-

17. 0625_s20_qp_21 Q:25

Sound travels through air as a series of compressions and rarefactions.

Which statement correctly compares a compression with a rarefaction?

- A** In a compression the wavelength is longer than in a rarefaction.
B In a compression the wavelength is shorter than in a rarefaction.
C In a compression the density of the air is greater than in a rarefaction.
D In a compression the density of the air is lower than in a rarefaction.
-

18. 0625_s20_qp_22 Q:25

A dolphin sends out a sound wave. An echo returns 0.010 s later from a fish which is 7.5 m from the dolphin.

What is the speed of the sound wave in water?

- A** 0.075 m/s **B** 0.15 m/s **C** 750 m/s **D** 1500 m/s
-

19. 0625_s20_qp_23 Q:25

Two people are standing outdoors on either side of a high wall.

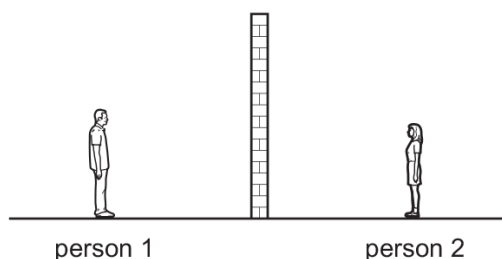

Person 1 can hear person 2 talking although he cannot see her.

Which statement explains this?

- A The sound waves have diffracted around the wall.
- B The sound waves have passed unaffected through the wall.
- C The sound waves have reflected around the wall.
- D The sound waves have refracted around the wall.

20. 0625_w20_qp_21 Q:25

Which row gives possible values for the speed of sound?

	<u>speed in gas</u> m/s	<u>speed in liquid</u> m/s	<u>speed in solid</u> m/s
A	972	1450	3560
B	972	3560	1450
C	1450	3560	972
D	3560	972	1450

Paper Perfection, Crafted With Passion

21. 0625_w20_qp_21 Q:26

A police car with its siren sounding is stationary in heavy traffic. A pedestrian notices that, although the loudness of the sound produced does not change, the pitch varies.

Which row describes the amplitude and the frequency of the sound?

	amplitude	frequency
A	constant	constant
B	constant	varying
C	varying	constant
D	varying	varying

3.4. SOUND

22. 0625_w20_qp_22 Q: 22

A radio transmitter broadcasts at a frequency of 200 kHz.

What is the wavelength of these radio waves?

- A** 6.7×10^{-4} m **B** 1.5 m **C** 1.5×10^3 m **D** 1.5×10^6 m
-

23. 0625_w20_qp_22 Q: 26

A police car with its siren sounding is stationary in heavy traffic. A pedestrian notices that, although the loudness of the sound produced does not change, the pitch varies.

Which row describes the amplitude and the frequency of the sound?

	amplitude	frequency
A	constant	constant
B	constant	varying
C	varying	constant
D	varying	varying

24. 0625_w20_qp_23 Q: 26

A sound wave travels through air.

What name is given to a region in which the air molecules are further apart than normal?

- A** compression
B contraction
C rarefaction
D vacuum
-

25. 0625_w20_qp_23 Q: 27

A police car with its siren sounding is stationary in heavy traffic. A pedestrian notices that, although the loudness of the sound produced does not change, the pitch varies.

Which row describes the amplitude and the frequency of the sound?

	amplitude	frequency
A	constant	constant
B	constant	varying
C	varying	constant
D	varying	varying

26. 0625_m19_qp_22 Q:26

A sound wave passes a point. The air pressure at that point increases and then decreases 300 times every second.

Which descriptions apply to this sound wave?

	the type of wave motion	the frequency of the sound
A	longitudinal	outside human hearing range
B	longitudinal	within human hearing range
C	transverse	outside human hearing range
D	transverse	within human hearing range

27. 0625_m19_qp_22 Q:27

A boy stands 150m from a wall. He claps and when he hears the echo, he immediately claps again. He continues this for some time.

Another student has a stop-watch. She starts the watch on the first clap and stops it on the eleventh clap. The watch reads 10.0s.

Which value do her measurements give for the speed of sound in air?

- A** 150m/s **B** 170m/s **C** 300m/s **D** 330m/s

28. 0625_s19_qp_21 Q:24

A pulse of sound is produced at the bottom of a boat. The sound travels through the water and is reflected from a shoal of fish. The sound reaches the boat again after 1.2s. The speed of sound in the water is 1500m/s.

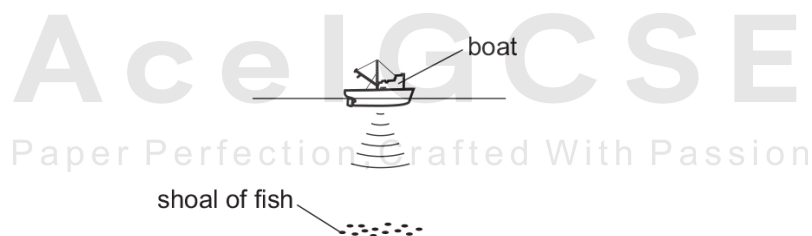

How far below the bottom of the boat is the shoal of fish?

- A** 450m **B** 900m **C** 1800m **D** 3600m

29. 0625_s19_qp_21 Q:25

What is the approximate value of the speed of sound in air at normal temperature?

- A** 340m/s **B** 34 000m/s **C** 340km/s **D** 3.0×10^8 m/s

3.4. SOUND

30. 0625_s19_qp_22 Q:25

An observer stands at the finish line of a 100 m race. He wants to time the winner's run. He starts his stop-watch as soon as he sees the smoke from the starting gun instead of when he hears the bang.

What is the reason for doing this?

- A Light travels much faster than sound.
 - B There is a risk he might respond to an echo from a wall.
 - C Humans react slower to sound than to light.
 - D Humans react more quickly to sound than to light.
-

31. 0625_s19_qp_23 Q:25

Which statement about ultrasound is correct?

- A It has a higher frequency than audible sound, and it is a longitudinal wave.
 - B It has a higher frequency than audible sound, and it is a transverse wave.
 - C It has a lower frequency than audible sound, and it is a longitudinal wave.
 - D It has a lower frequency than audible sound, and it is a transverse wave.
-

32. 0625_w19_qp_21 Q:25

Which row gives a possible set of values for the speed of sound in ice, in water and in steam?

	speed of sound in ice m/s	speed of sound in water m/s	speed of sound in steam m/s
A	500	1500	4000
B	1500	4000	500
C	4000	500	1500
D	4000	1500	500

33. 0625_m18_qp_22 Q:27

Both the amplitude and the frequency of a sound wave decrease.

What happens to the sound heard?

- A The sound is louder and has a higher pitch.
 - B The sound is louder and has a lower pitch.
 - C The sound is quieter and has a higher pitch.
 - D The sound is quieter and has a lower pitch.
-

34. 0625_m18_qp_22 Q:28

A sound wave is travelling through water.

What is a possible speed for the wave?

- A** 150 m/s **B** 300 m/s **C** 1500 m/s **D** 5000 m/s
-

35. 0625_s18_qp_21Q:24

A dolphin has a range of audible frequencies of 150 Hz–150 kHz.

Which range of frequencies can be heard both by humans with good hearing and by dolphins?

- A** 20 Hz–150 Hz
B 20 Hz–150 kHz
C 20 kHz–150 kHz
D 150 Hz–20 kHz
-

36. 0625_s18_qp_22 Q:24

A siren is emitting a sound. As time passes, the sound becomes louder and higher pitched.

What is happening to the amplitude and to the frequency of the emitted sound wave?

	amplitude	frequency
A	decreasing	decreasing
B	decreasing	increasing
C	increasing	decreasing
D	increasing	increasing

Paper Perfection, Crafted With Passion

3.4. SOUND

37. 0625_s18_qp_23 Q:23

The diagram shows the air molecules in part of a sound wave at a particular moment in time.

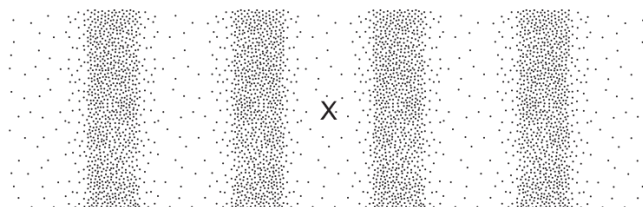

Which statement is **not** correct?

- A Earlier, there was compression at X.
- B Later, there will be a rarefaction at X.
- C This part of the wave is travelling horizontally across the page.
- D This part of the wave is travelling towards the top of the page.

38. 0625_s18_qp_23 Q:24

The diagram shows the ranges of human hearing and of ultrasound waves.

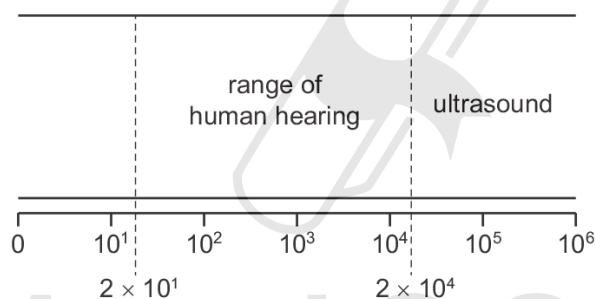

To which characteristic of sound waves do the numbers on the diagram refer?

- A amplitude in cm
- B frequency in Hz
- C speed in metres/second
- D wavelength in metres

39. 0625_w18_qp_21 Q:26

A sheet of ice floats on water. A source of sound S is positioned at the edge of the ice sheet.

Four microphones are placed equal distances from S.

Which microphone detects the sound from S first?

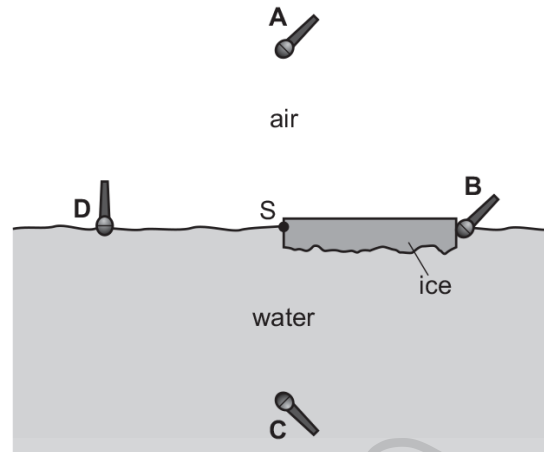

40. 0625_m17_qp_22 Q:23

Which statement about sound waves is correct?

- A They are able to travel through a vacuum.
- B They are able to travel through solids.
- C They are transverse waves.
- D They travel at the same speed in all substances.

41. 0625_m17_qp_22 Q:24

Which statement about ultrasound is correct?

- A It is produced by a rapidly vibrating source.
- B It is uncomfortable to human ears.
- C Its frequency must be greater than 300 kHz.
- D It travels the fastest in a vacuum.

3.4. SOUND

42. 0625_s17_qp_23 Q:23

A fire alarm is not loud enough and the pitch is too low. An engineer adjusts the alarm so that it produces a louder note of a higher pitch.

What effect does this have on the amplitude and on the frequency of the sound?

	amplitude	frequency
A	larger	greater
B	larger	smaller
C	smaller	greater
D	smaller	smaller

43. 0625_w17_qp_21 Q:25

Which wavefront is travelling at a speed closest to that of a sound wave through a solid?

- A** one that moves 10 m in 0.01 s
- B** one that moves 50 m in 0.5 s
- C** one that moves 1000 m in 100 s
- D** one that moves 2000 m in 2000 s

44. 0625_w17_qp_21 Q:26

Different waves travel through air.

Which waves have the greatest difference in speed?

- A** ultrasound waves and sound waves
- B** ultrasound waves and ultraviolet waves
- C** ultraviolet waves and light waves
- D** ultraviolet waves and radio waves

45. 0625_w17_qp_21 Q:27

A student stands 180 m in front of a vertical, flat cliff and bangs together two pieces of wood to make a short, loud sound.

A timer records the echo of the sound 1.5 seconds after the pieces of wood are banged together.

Based on this result, what is the speed of sound?

- A** 120 m/s
- B** 240 m/s
- C** 270 m/s
- D** 540 m/s

46. 0625_w17_qp_22 Q:26

The speed of sound is different in different states of matter.

The speed of sound in water is 1500 m/s.

Which row correctly compares the speed of sound in ice and the speed of sound in steam with the speed of sound in water?

	<u>speed of sound in ice</u> m/s	<u>speed of sound in steam</u> m/s
A	less than 1500	less than 1500
B	less than 1500	more than 1500
C	more than 1500	less than 1500
D	more than 1500	more than 1500

47. 0625_w17_qp_22 Q:27

A student finds that it takes sound 0.33 seconds to travel 100 metres.

From this information, what is the speed of sound?

- A** 30 m/s **B** 60 m/s **C** 300 m/s **D** 600 m/s

48. 0625_w17_qp_23 Q:23

A sound wave travels from a medium in one state into the same medium but in another state. This causes the speed of the wave to change from approximately 300 m/s to approximately 3000 m/s.

Between which two states is the sound wave travelling?

- A** gas to solid
B liquid to gas
C liquid to solid
D solid to liquid

3.4. SOUND

49.0625_w17_qp_23 Q:26

The diagram shows the Earth and its surroundings.

Through which labelled region can sound **not** be transmitted?

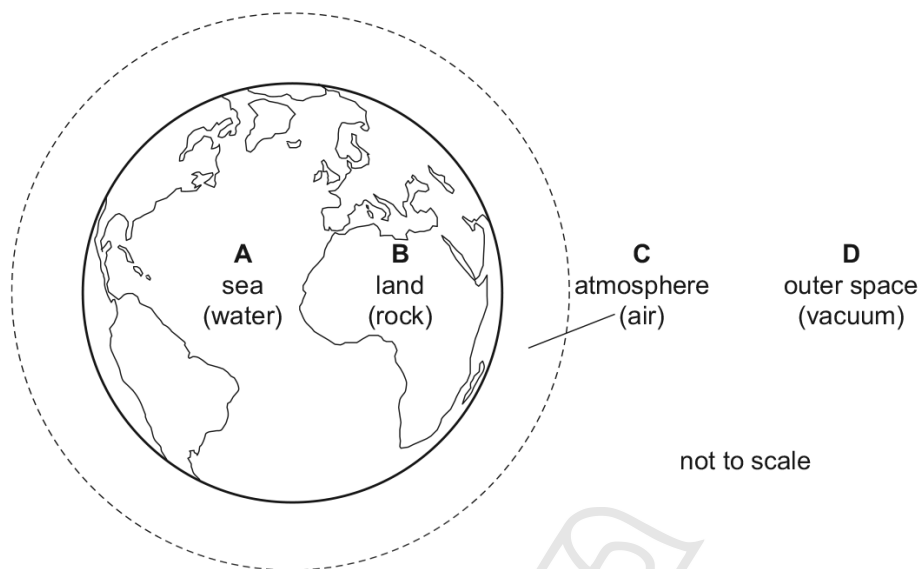

50.0625_m16_qp_22 Q:24

A sound wave travels from a point X to a point Y.



Which diagram represents the movement of the air molecules, due to the sound wave, in the region between X and Y?



51. 0625_m16_qp_22 Q:25

The speed of sound in air is 340m/s.

Which row gives typical values for the speed of sound in a liquid and in a solid?

	speed of sound in a liquid/(m/s)	speed of sound in a solid/(m/s)
A	250	180
B	250	5000
C	1500	180
D	1500	5000

52. 0625_s16_qp_21 Q:20

Sound waves of frequency 2.0kHz travel through a substance at a speed of 800m/s.

What is the wavelength of the waves?

A 0.40m **B** 2.5m **C** 400m **D** 1600m

53. 0625_s16_qp_21 Q:24

A sound wave travels through air as a series of compressions and rarefactions.

Which row correctly compares the air pressure in a compression and the air pressure in a rarefaction to the air pressure nearby where there is no sound wave?

	air pressure in a compression	air pressure in a rarefaction
A	higher	higher
B	higher	lower
C	lower	higher
D	lower	lower

3.4. SOUND

54. 0625_s16_qp_21 Q:25

A sound wave has a certain amplitude and a certain frequency.

A second sound wave is quieter and lower in pitch than the first sound wave.

The second wave has

- A a larger amplitude and a greater frequency.
- B a larger amplitude and a smaller frequency.
- C a smaller amplitude and a greater frequency.
- D a smaller amplitude and a smaller frequency.

55. 0625_s16_qp_22 Q:22

Which row shows the natures of light waves, sound waves and X-rays?

	light waves	sound waves	X-rays
A	longitudinal	longitudinal	transverse
B	longitudinal	transverse	longitudinal
C	transverse	longitudinal	transverse
D	transverse	transverse	longitudinal

56. 0625_s16_qp_23 Q:25

The sound from a loudspeaker must pass through two materials to reach a microphone.

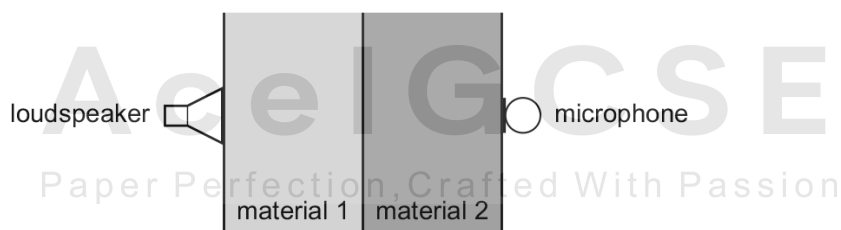

Which combination of materials gives the shortest time for the sound to reach the microphone?

	material 1	material 2
A	air	hydrogen
B	air	water
C	copper	aluminium
D	water	oil

57. 0625_s16_qp_23 Q:26

Which range of wave frequencies includes only sounds that can be heard by a human with normal hearing?

- A 3.0 Hz to 300 Hz
- B 30 Hz to 3000 Hz
- C 300 Hz to 30 000 Hz
- D 3000 Hz to 300 000 Hz

58. 0625_w16_qp_21 Q:25

A girl notices that, when she shouts into a cave, she hears an echo.

Which wave property causes the echo?

- A diffraction
- B dispersion
- C reflection
- D refraction

59. 0625_w16_qp_21 Q:26

The diagrams represent the displacement in four different sound waves. All the diagrams are drawn to the same scale.

Which diagram represents the sound with the highest pitch?

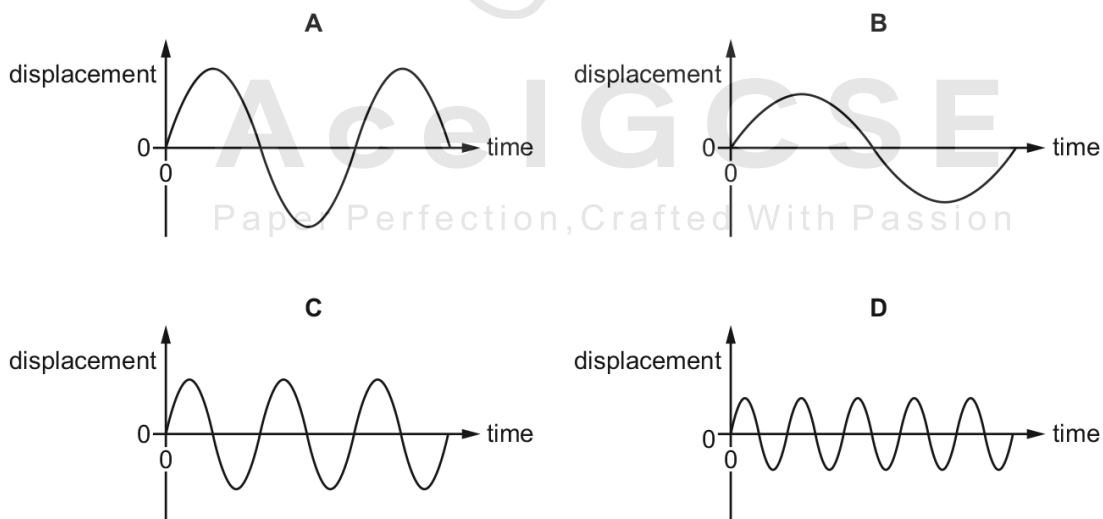

3.4. SOUND

60. 0625_w16_qp_22 Q: 26

Which property of a sound wave affects the loudness of the sound?

- A amplitude
 - B frequency
 - C speed
 - D wavelength
-

61. 0625_w16_qp_23 Q: 24

A girl notices that, when she shouts into a cave, she hears an echo.

Which wave property causes the echo?

- A diffraction
 - B dispersion
 - C reflection
 - D refraction
-

62. 0625_w16_qp_23 Q: 25

A man stands 110m from a high wall. He makes a short, sharp sound and then hears an echo from the wall.

The speed of sound in air is 330 m/s.

How long after making the sound does the man hear the echo?

- A 0.33s
 - B 0.67s
 - C 1.5s
 - D 3.0s
-

63. 0625_m15_qp_12 Q: 23

What is the approximate range of audible sound frequencies for a human with good hearing?

- A from 20 Hz to 2000 Hz
 - B from 20 Hz to 20 000 Hz
 - C from 200 Hz to 20 000 Hz
 - D from 200 Hz to 200 000 Hz
-

64. 0625_m15_qp_12 Q:24

A pulse of sound is produced at the bottom of a boat. The sound travels through the water and is reflected from the sea-bed. The sound reaches the boat again after 1.3 s. The sea-bed is 1000 m below the boat.

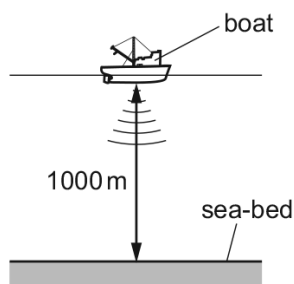

Using this information, what is the speed of sound in the water?

- A** 769 m/s **B** 1300 m/s **C** 1538 m/s **D** 2600 m/s

65. 0625_s15_qp_11 Q:23

Which row states two properties of sound waves?

	can travel through	type of wave
A	a vacuum	longitudinal
B	a vacuum	transverse
C	water	longitudinal
D	water	transverse

66. 0625_s15_qp_11 Q:24

A man holding a starting pistol stands 640 m away from a spectator.

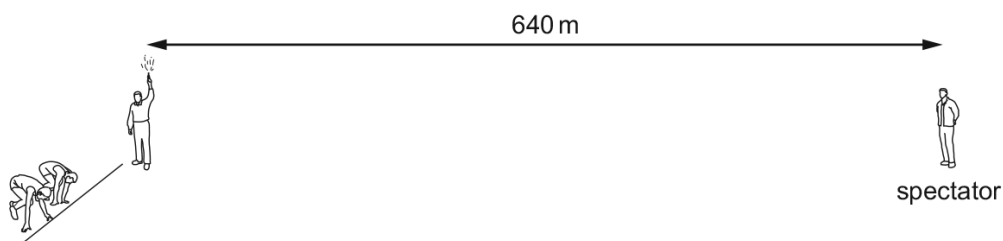

The spectator hears the sound of the starting pistol 2.0 s after seeing the flash from the pistol.

Using this information, what is the speed of sound in air?

- A** 160 m/s **B** 320 m/s **C** 640 m/s **D** 1280 m/s

3.4. SOUND

67. 0625_s15_qp_12 Q:23

A quiet sound is produced by a loudspeaker. The loudness of the sound is increased.

Which property of the sound wave is increased?

- A amplitude
- B frequency
- C speed
- D wavelength

68. 0625_s15_qp_13 Q:23

The frequency of a musical note is increased.

A student hearing the sound detects an increase in which property?

- A loudness of the sound
- B pitch of the sound
- C speed of the sound wave
- D wavelength of the sound wave

69. 0625_w15_qp_11 Q:23

Which row states whether light waves and whether sound waves can travel in a vacuum?

	sound waves	light waves
A	no	no
B	no	yes
C	yes	no
D	yes	yes

70. 0625_w15_qp_11 Q:24

Sounds are produced by vibrating objects. A certain object vibrates but a person nearby cannot hear any sound.

Which statement could explain why nothing is heard?

- A The amplitude of the sound waves is too large.
 - B The frequency of the vibration is too high.
 - C The sound waves are transverse.
 - D The speed of the sound waves is too high.
-

71. 0625_w15_qp_12 Q:23

Two sounds X and Y are produced by loudspeakers.

The amplitude and frequency of each sound wave is given in the table.

	amplitude/mm	frequency/Hz
X	1.3	475
Y	2.0	235

How does sound Y compare with sound X?

- A Y is louder and has a higher pitch.
- B Y is louder and has a lower pitch.
- C Y is quieter and has a higher pitch.
- D Y is quieter and has a lower pitch.

72. 0625_s14_qp_11 Q:23

A boy blows a whistle that has a frequency of 10000Hz. The boy's friend cannot hear the sound from the whistle. The friend has normal hearing.

What could be a reason why he cannot hear the sound?

- A The amplitude is too large.
- B The amplitude is too small.
- C The frequency is too high.
- D The frequency is too low.

3.4. SOUND

73.0625_s14_qp_11 Q:24

A lit candle is placed in front of a loudspeaker that is making a loud, steady note. The candle flame vibrates because of the sound wave.

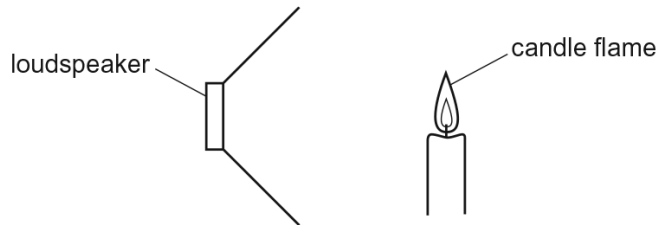

Which type of waves are sound waves and in which direction does the flame vibrate?

	type of wave	direction of vibration
A	longitudinal	↑ ↓
B	transverse	↑ ↓
C	longitudinal	← →
D	transverse	← →

74.0625_s14_qp_12 Q:24

The diagrams show the wave patterns of four sounds shown on a cathode-ray oscilloscope (c.r.o.). The oscilloscope controls are set the same for each sound.

Which sound has the highest pitch?

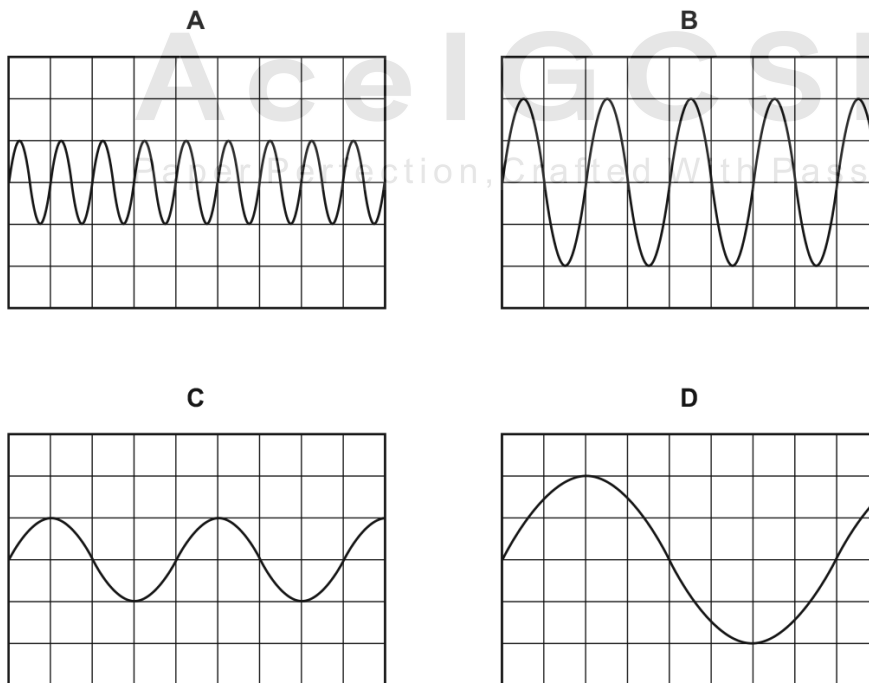

75. 0625_w14_qp_11 Q:24

A fire alarm is not loud enough and the pitch is too low. An engineer adjusts the alarm so that it produces a louder note of a higher pitch.

What effect does this have on the amplitude and on the frequency of the sound waves that the alarm produces?

	amplitude	frequency
A	larger	larger
B	larger	smaller
C	smaller	larger
D	smaller	smaller

76. 0625_w14_qp_11 Q:25

In an experiment to measure the speed of sound, a student uses a stopwatch to find the time taken for a sound wave to travel from X to Y. She does this six times.

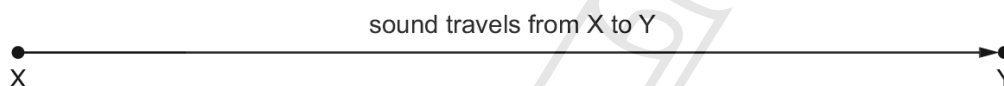

The table shows her results.

measurement	time / s
first	0.5
second	0.7
third	0.6
fourth	0.4
fifth	0.9
sixth	0.5

Which value for the time should be used to calculate the speed of sound?

- A** 0.4 s **B** 0.5 s **C** 0.6 s **D** 0.9 s

3.4. SOUND

77. 0625_w14_qp_13 Q:24

Three vibrating objects P, Q and R produce waves in the air of different frequencies as shown.

object	frequency / Hz
P	25
Q	1000
R	15000

Which of these waves can be heard by a human ear?

- A P, Q and R
- B P and Q only
- C P and R only
- D Q and R only

78. 0625_s13_qp_11 Q:24

The diagrams represent two sound waves. The scales in the two diagrams are the same.

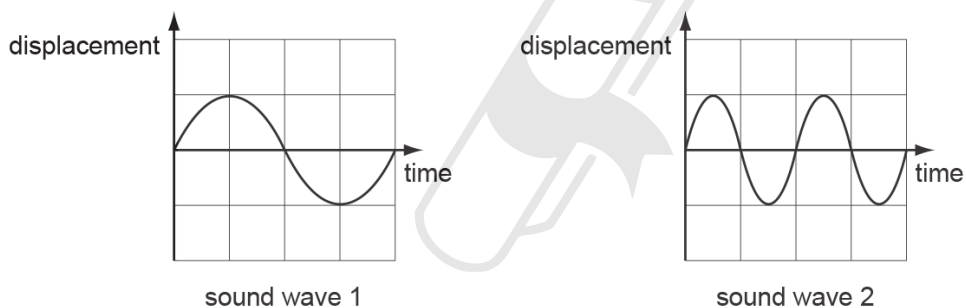

Which statement describes the waves?

- A The waves have different loudness and different pitch.
- B The waves have different loudness but the same pitch.
- C The waves have the same loudness and the same pitch.
- D The waves have the same loudness but different pitch.

79. 0625_s13_qp_11 Q:25

A student claps once when standing 100m away from a large wall.

The speed of sound in air is 330 m/s.

How long after clapping does the student hear an echo?

- A 0.30s
- B 0.61s
- C 1.7s
- D 3.3s

80. 0625_s13_qp_12 Q:24

A tuning fork is marked with the number 320.

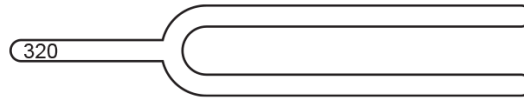

This indicates the size of the frequency.

What does this mean?

- A The length of the tuning fork is 320 mm.
- B The note from the tuning fork will last for up to 320 s.
- C The sound waves produced by the tuning fork travel at 320 m/s.
- D The tuning fork vibrates 320 times every second.

81. 0625_s13_qp_12 Q:25

Some sound from a loudspeaker at P travels directly to Q. Sound also reaches Q after being reflected from a wall at R.

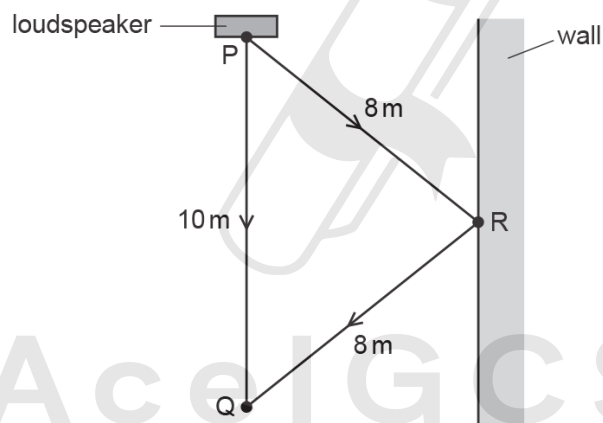

The speed of sound is 330 m/s.

What is the **difference** in time for a sound to travel from P to Q by the two routes?

- A $\left(\frac{6}{330}\right)$ s
- B $\left(\frac{16}{330}\right)$ s
- C (6×330) s
- D (16×330) s

3.4. SOUND

82. 0625_w13_qp_11 Q:24

When the volcano Krakatoa erupted in 1883, it was heard 5000 km away.

Which statement about the sound from the volcano is **not** correct?

- A If such a loud sound were to be made today, an astronaut orbiting in space (a vacuum) at a height of 400 km could hear it.
 - B People further from the volcano heard the sound later than people nearer to the volcano.
 - C The amplitude of the sound waves would have been smaller further from the volcano.
 - D The sound was very loud because a lot of energy was transferred to vibrations of the air.
-

83. 0625_w13_qp_11 Q:25

A loudspeaker on a boat produces a pulse of sound in the sea. The echo of the pulse is received back at the boat after 3.0 s. The depth of the sea under the boat is 2250 m.

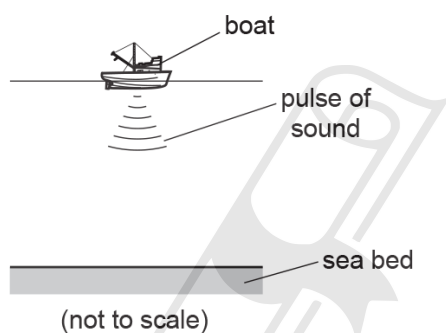

From this information, what is the speed of sound in the sea water?

- A 330 m/s
 - B 750 m/s
 - C 1500 m/s
 - D 6750 m/s
-

84. 0625_w13_qp_13 Q:24

To estimate the width of a valley, a climber starts a stopwatch as he shouts. He hears an echo from the opposite side of the valley after 1.0 s.



The sound travels at 330 m/s.

What is the width of the valley?

- A 82.5 m
 - B 165 m
 - C 330 m
 - D 660 m
-

85. 0625_w13_qp_13 Q:25

A police car sounds its siren when travelling to an emergency. The siren produces two different sounds P and Q, which are emitted alternately.

The diagram represents the sound waves emitted by the siren.

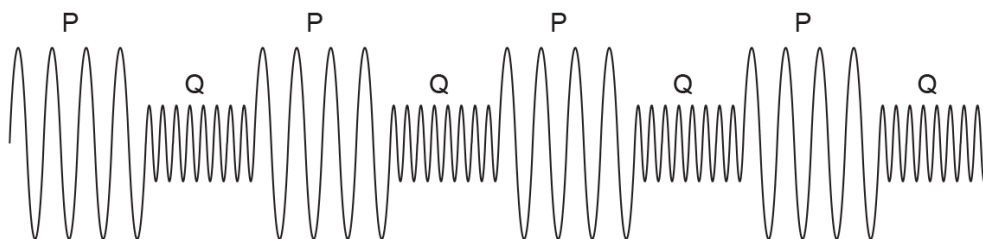

Which of the two sounds P and Q is the louder and which has the higher pitch?

	louder sound	sound of higher pitch
A	P	P
B	P	Q
C	Q	P
D	Q	Q

86. 0625_s12_qp_11 Q:25

A girl stands at a distance from a large building. She claps her hands and a short time later hears an echo.

Why is an echo produced when the sound waves hit the building?

- A** The sound waves are absorbed.
- B** The sound waves are diffracted.
- C** The sound waves are reflected.
- D** The sound waves are refracted.

3.4. SOUND

87.0625_s12_qp_11 Q:26

The diagrams represent the waves produced by four sources of sound. The scales are the same for all the diagrams.

Which sound has the highest frequency?

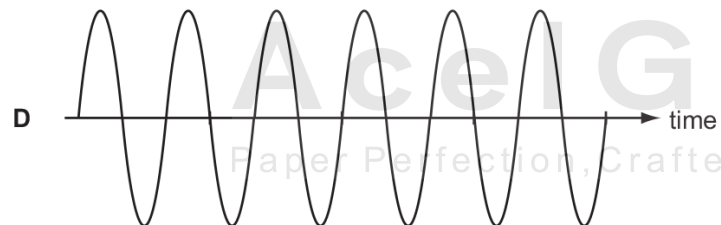
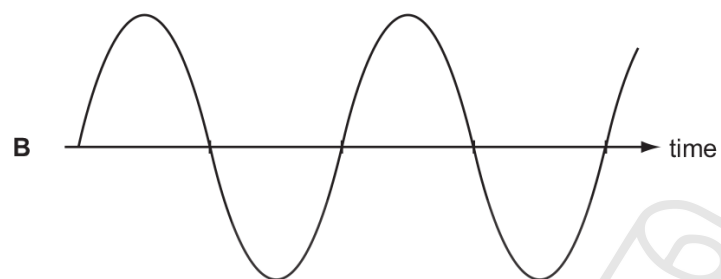
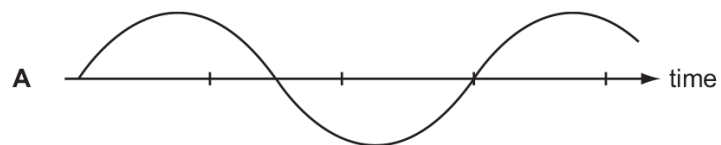

AcelGCSE
Paper Perfection, Crafted With Passion

88. 0625_s12_qp_12 Q:25

A girl stands at a distance from a large building. She claps her hands and a short time later hears an echo.

Why is an echo produced when the sound waves hit the building?

- A The sound waves are absorbed.
- B The sound waves are diffracted.
- C The sound waves are reflected.
- D The sound waves are refracted.

89. 0625_s12_qp_12 Q:26

Three loudspeakers vibrate at different frequencies of 5 hertz, 25 kilohertz and 50 kilohertz.



Which row shows whether the vibrations from each loudspeaker can be heard by a human?

	5 hertz	25 kilohertz	50 kilohertz
A	no	no	no
B	no	yes	no
C	yes	no	yes
D	yes	yes	yes

90. 0625_w12_qp_11 Q:26

In a test, a car horn is found to be too loud and the pitch of the note is too high.

What information does this give about the amplitude and the frequency of the sound wave produced?

	amplitude	frequency
A	too large	too large
B	too large	too small
C	too small	too large
D	too small	too small

3.4. SOUND

91.0625_w12_qp_13 Q:25

Sound waves may cause an echo.

What happens to sound waves to cause an echo and what is the nature of sound waves?

	what an echo is caused by	nature of sound waves
A	reflection	longitudinal
B	reflection	transverse
C	refraction	longitudinal
D	refraction	transverse



AceIGCSE
Paper Perfection, Crafted With Passion

SN	Paper	Q. No.	Answer
01	0625_s12_qp_12	22	B
02	0625_w12_qp_13	22	D
03	0625_m22_qp_22	26	A
04	0625_m21_qp_22	20	A
05	0625_m21_qp_22	26	B
06	0625_m21_qp_22	27	C
07	0625_s21_qp_21	26	B
08	0625_s21_qp_21	27	C
09	0625_s21_qp_23	26	D
10	0625_s21_qp_23	27	C
11	0625_w21_qp_21	24	B
12	0625_w21_qp_23	17	A
13	0625_w21_qp_23	23	A
14	0625_w21_qp_23	24	B
15	0625_m20_qp_22	28	C
16	0625_p20_qp_20	27	B
17	0625_s20_qp_21	25	C
18	0625_s20_qp_22	25	D
19	0625_s20_qp_23	25	A
20	0625_w20_qp_21	25	A
21	0625_w20_qp_21	26	B
22	0625_w20_qp_22	22	C
23	0625_w20_qp_22	26	B
24	0625_w20_qp_23	26	C
25	0625_w20_qp_23	27	B
26	0625_m19_qp_22	26	B
27	0625_m19_qp_22	27	C
28	0625_s19_qp_21	24	A
29	0625_s19_qp_21	25	D
30	0625_s19_qp_22	25	A
31	0625_s19_qp_23	25	A
32	0625_w19_qp_21	25	D
33	0625_m18_qp_22	27	D
34	0625_m18_qp_22	28	C
35	0625_s18_qp_21	24	D
36	0625_s18_qp_22	24	D
37	0625_s18_qp_23	23	D
38	0625_s18_qp_23	24	B
39	0625_w18_qp_21	26	B
40	0625_m17_qp_22	23	B
41	0625_m17_qp_22	24	A
42	0625_s17_qp_23	23	A
43	0625_w17_qp_21	25	A
44	0625_w17_qp_21	26	B
45	0625_w17_qp_21	27	B
46	0625_w17_qp_22	26	C
47	0625_w17_qp_22	27	C
48	0625_w17_qp_23	23	A
49	0625_w17_qp_23	26	D

SN	Paper	Q. No.	Answer
50	0625_m16_qp_22	24	D
51	0625_m16_qp_22	25	D
52	0625_s16_qp_21	20	A
53	0625_s16_qp_21	24	B
54	0625_s16_qp_21	25	D
55	0625_s16_qp_22	22	C
56	0625_s16_qp_23	25	C
57	0625_s16_qp_23	26	B
58	0625_w16_qp_21	25	C
59	0625_w16_qp_21	26	D
60	0625_w16_qp_22	26	A
61	0625_w16_qp_23	24	C
62	0625_w16_qp_23	25	B
63	0625_m15_qp_12	23	B
64	0625_m15_qp_12	24	C
65	0625_s15_qp_11	23	C
66	0625_s15_qp_11	24	B
67	0625_s15_qp_12	23	A
68	0625_s15_qp_13	23	B
69	0625_w15_qp_11	23	B
70	0625_w15_qp_11	24	B
71	0625_w15_qp_12	23	B
72	0625_s14_qp_11	23	B
73	0625_s14_qp_11	24	C
74	0625_s14_qp_12	24	A
75	0625_w14_qp_11	24	A
76	0625_w14_qp_11	25	C
77	0625_w14_qp_13	24	A
78	0625_s13_qp_11	24	D
79	0625_s13_qp_11	25	B
80	0625_s13_qp_12	24	D
81	0625_s13_qp_12	25	A
82	0625_w13_qp_11	24	A
83	0625_w13_qp_11	25	C
84	0625_w13_qp_13	24	B
85	0625_w13_qp_13	25	B
86	0625_s12_qp_11	25	C
87	0625_s12_qp_11	26	D
88	0625_s12_qp_12	25	C
89	0625_s12_qp_12	26	A
90	0625_w12_qp_11	26	A
91	0625_w12_qp_13	25	A