

### 1.5. FORCES

01. 0625\_s12\_qp\_11 Q: 6

A stone has a volume of  $0.50 \text{ cm}^3$  and a mass of  $2.0 \text{ g}$ .

What is the density of the stone?

- A  $0.25 \text{ g/cm}^3$
  - B  $1.5 \text{ g/cm}^3$
  - C  $2.5 \text{ g/cm}^3$
  - D  $4.0 \text{ g/cm}^3$
- 

02. 0625\_w12\_qp\_11 Q: 6

A liquid has a density of  $0.80 \text{ g/cm}^3$ .

Which could be the volume and mass of this liquid?

	volume / $\text{cm}^3$	mass / g
A	2.0	16
B	8.0	10
C	10	8.0
D	16	2.0

---

### 1.5 Forces

03. 0625\_m22\_qp\_22 Q: 6

A car has a mass of  $1500 \text{ kg}$ . A constant resultant force acts on the car and the car accelerates from  $15 \text{ m/s}$  to  $20 \text{ m/s}$  in  $4.0$  seconds.

What is the magnitude of the resultant force acting on the car?

- A  $300 \text{ N}$
  - B  $1200 \text{ N}$
  - C  $1900 \text{ N}$
  - D  $7500 \text{ N}$
- 

04. 0625\_m22\_qp\_22 Q: 7

A metal wire is loaded up to the limit of proportionality.

Which statement is correct?

- A Hooke's law is not obeyed when the load is increased from zero to this point.
  - B When the load is increased beyond the limit of proportionality, the diameter of the wire will increase.
  - C When the load is removed, the wire returns to its original length.
  - D Up to the limit of proportionality, there is no change in the shape of the wire.
-

05. 0625\_m22\_qp\_22 Q: 8

The diagram shows a uniform metre rule, MN, pivoted at its midpoint P.

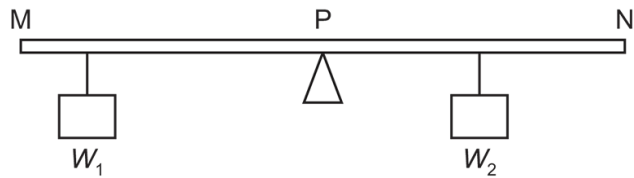

Two weights,  $W_1$  and  $W_2$ , are hung either side of the pivot.

The rule remains balanced.

Which row is correct?

	direction of resultant moment about point M	direction of resultant force on the rule
<b>A</b>	clockwise	downwards
<b>B</b>	clockwise	zero
<b>C</b>	zero	downwards
<b>D</b>	zero	zero

06. 0625\_m22\_qp\_22 Q: 9

Which physical quantity is a vector?

- A** mass
- B** density
- C** temperature
- D** velocity

AcelGCSE

Paper Perfection, Crafted With Passion

07. 0625\_m22\_qp\_22 Q: 10

A resultant force of 500 N acts for 10 s on a car of mass 1000 kg. This causes the velocity of the car to double.

What is the final velocity of the car?

- A** 5 m/s      **B** 10 m/s      **C** 20 m/s      **D** 50 m/s

08. 0625\_m21\_qp\_22 Q: 6

An object of mass 0.80 kg is moving in a straight line at a velocity of 2.0 m/s. A force is exerted on the object, in the direction of motion, for a period of 1.0 minute and the velocity of the object increases to 6.0 m/s.

What force is exerted on the object?

- A** 0.053 N      **B** 0.080 N      **C** 3.2 N      **D** 4.8 N

1.5. FORCES

09.0625\_m21\_qp\_22 Q: 7

An object moves at constant speed in the circular path shown.

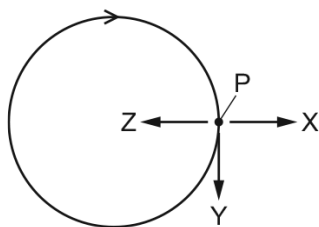

Which statement about the acceleration of the object when it is at point P is correct?

- A The acceleration is in the direction of arrow X.
- B The acceleration is in the direction of arrow Y.
- C The acceleration is in the direction of arrow Z.
- D The object is not accelerating.

10.0625\_m21\_qp\_22 Q: 8

An object is pivoted at point P. A student ties a length of string to a peg on the object. He pulls the string with a force  $F$ .

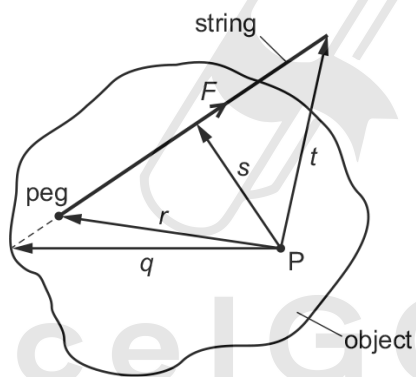

What is the moment of the force  $F$  about the point P?

- A  $F \times q$
- B  $F \times r$
- C  $F \times s$
- D  $F \times t$

11. 0625\_s21\_qp\_21 Q: 6

The extension–load graph for a spring is shown. The unstretched length of the spring is 17.0 cm.

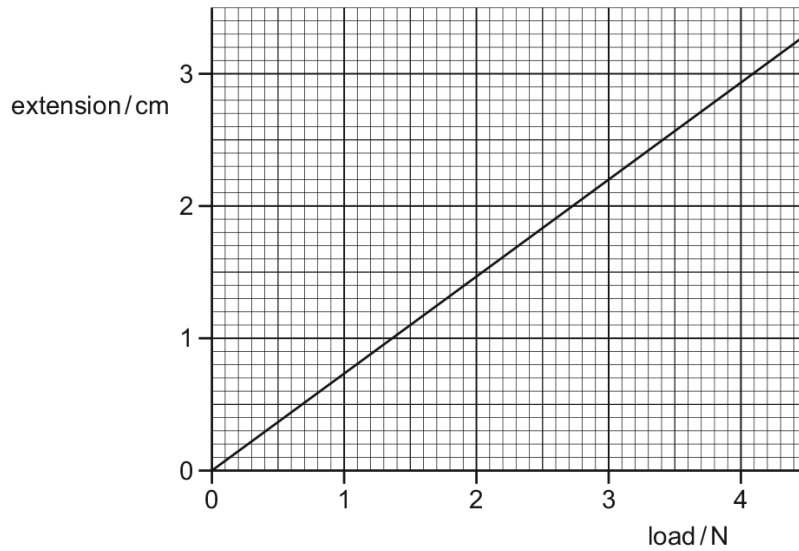

When an object is suspended from the spring, the length of the spring is 19.2 cm.

What is the weight of the object?

- A** 1.4 N      **B** 1.6 N      **C** 2.6 N      **D** 3.0 N

12. 0625\_s21\_qp\_21 Q: 7

A cart has a mass of 10 kg. A boy pushes on the cart horizontally with a force of 50 N. The cart accelerates at  $0.50 \text{ m/s}^2$ .

What is the frictional force acting on the cart?

- A** 5.0 N      **B** 20 N      **C** 30 N      **D** 45 N

13. 0625\_s21\_qp\_22 Q: 7

A satellite orbits the Earth in an anticlockwise direction at constant speed, as shown.

When the satellite is in the position shown, in which direction does the resultant force act upon it?

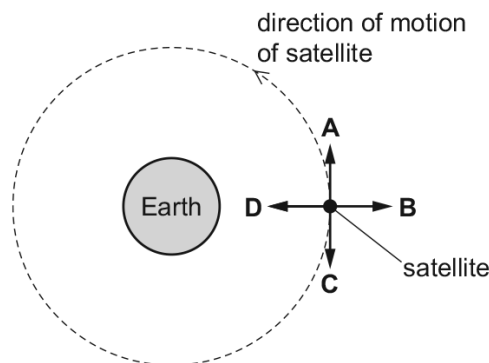

1.5. FORCES

14. 0625\_s21\_qp\_23 Q: 6

The extension-load graph for a spring is shown. The unstretched length of the spring is 17.0 cm.

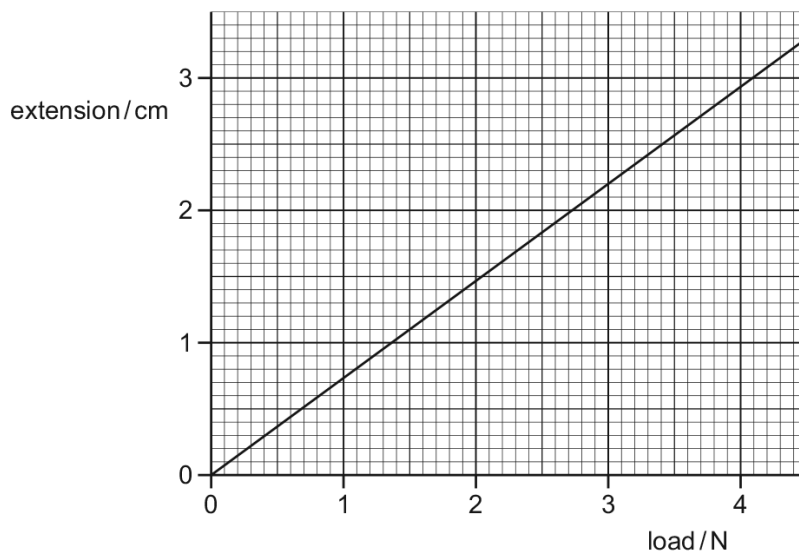

When an object is suspended from the spring, the length of the spring is 19.2 cm.

What is the weight of the object?

- A** 1.4 N      **B** 1.6 N      **C** 2.6 N      **D** 3.0 N
- 

15. 0625\_s21\_qp\_23 Q: 7

A car of mass 1200 kg is travelling along a horizontal road.

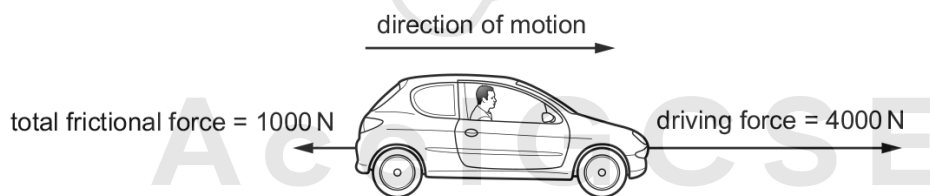

What is the acceleration of the car?

- A**  $0.83\text{ m/s}^2$       **B**  $1.2\text{ m/s}^2$       **C**  $2.5\text{ m/s}^2$       **D**  $3.3\text{ m/s}^2$
-

16. 0625\_w21\_qp\_21 Q: 5

A 20 m long, uniform bridge of weight 100 kN is supported at each end by pillars, as shown.

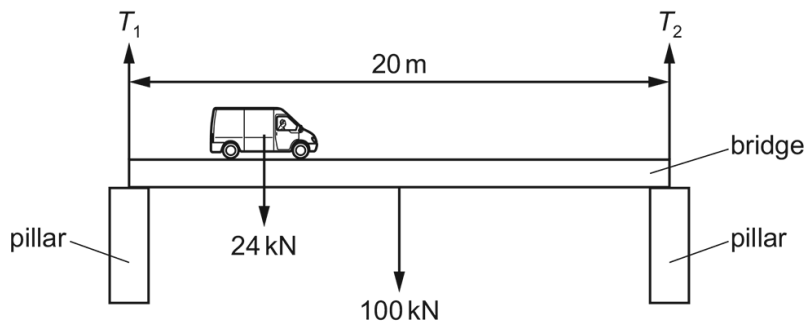

The pillars exert forces  $T_1$  and  $T_2$  on the ends of the bridge.

What are the values of  $T_1$  and  $T_2$  when a van of weight 24 kN is on the bridge, 5 m from the left-hand pillar?

	$T_1$ /kN	$T_2$ /kN
<b>A</b>	56	68
<b>B</b>	62	62
<b>C</b>	68	56
<b>D</b>	74	50

17. 0625\_w21\_qp\_21 Q: 6

A spring, which obeys Hooke's law, has an unstretched length of 10 cm.

A load of 20 N is suspended from the spring.

The new length of the spring is 36 cm.

What is the spring constant  $k$  of the spring?

- A** 0.56 N/cm    **B** 0.77 N/cm    **C** 1.3 N/cm    **D** 1.8 N/cm

1.5. FORCES

18. 0625\_w21\_qp\_22 Q: 5

Three simple machines are shown.



moving soil with a wheelbarrow

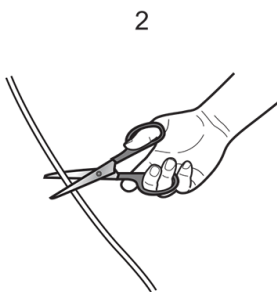

cutting string with scissors

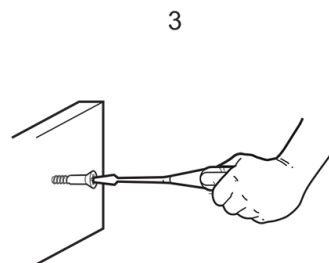

screwing a screw with a screwdriver

Which machines are an application of the moment of a force?

- A** 1, 2 and 3    **B** 1 and 2 only    **C** 1 and 3 only    **D** 2 and 3 only
- 

19. 0625\_w21\_qp\_22 Q: 6

A spring, which obeys Hooke's law, has an unstretched length of 10 cm.

A load of 20 N is suspended from the spring.

The new length of the spring is 36 cm.

What is the spring constant  $k$  of the spring?

- A** 0.56 N/cm    **B** 0.77 N/cm    **C** 1.3 N/cm    **D** 1.8 N/cm
- 

20. 0625\_w21\_qp\_23 Q: 5

The diagram shows a uniform bar resting on two supports, P and Q.

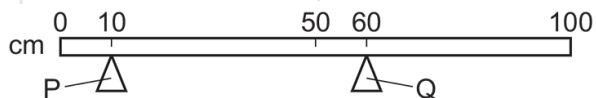

The weight of the bar is 4.0 N.

What is the force exerted on the bar by support P?

- A** 0.80 N    **B** 2.0 N    **C** 3.2 N    **D** 4.0 N
-

21. 0625\_w21\_qp\_23 Q: 6

A spring, which obeys Hooke's law, has an unstretched length of 10 cm.

A load of 20 N is suspended from the spring.

The new length of the spring is 36 cm.

What is the spring constant  $k$  of the spring?

- A** 0.56 N/cm    **B** 0.77 N/cm    **C** 1.3 N/cm    **D** 1.8 N/cm

---

22. 0625\_m20\_qp\_22 Q: 7

A car travels along a horizontal road at constant speed. Three horizontal forces act on the car. The diagram shows two of these forces.

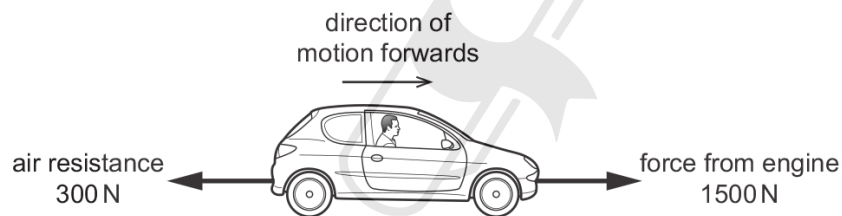

What is the size and the direction of the third horizontal force acting on the car?

- A** 1200 N backwards  
**B** 1200 N forwards  
**C** 1800 N backwards  
**D** 1800 N forwards

1.5. FORCES

23. 0625\_m20\_qp\_22 Q: 8

A car is driven round a bend in the road at a constant speed.

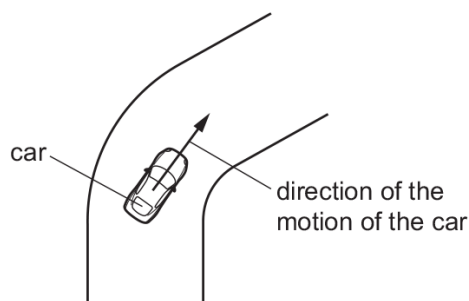

What is the direction of the resultant force on the car when it is going round the bend?

- A parallel to the motion and in the same direction as the motion
  - B parallel to the motion and in the opposite direction to the motion
  - C perpendicular to the motion and towards the inside of the bend
  - D perpendicular to the motion and towards the outside of the bend
- 

24. 0625\_m20\_qp\_22 Q: 9

An athlete with mass 70 kg trains by performing press-ups with a load on his back. The diagram shows the perpendicular distances involved.

The centre of mass of the athlete is  $C_M$  and the centre of mass of the load he is carrying is  $C_L$ .

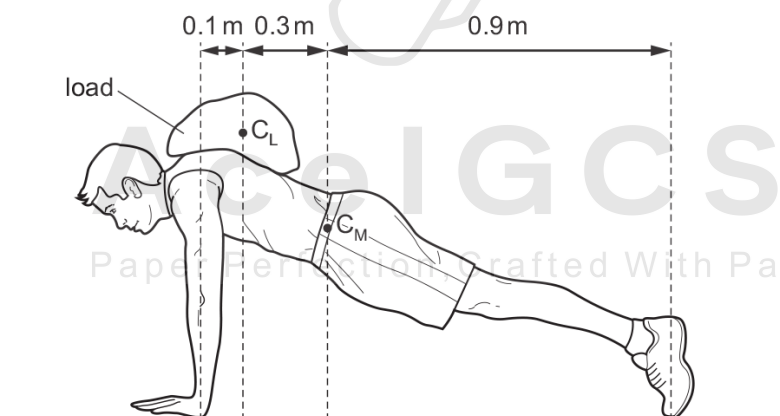

The mass of the load is 6.0 kg.

What is the upward force exerted by his two arms?

- A 54 N
  - B 76 N
  - C 540 N
  - D 760 N
-

25. 0625\_p20\_qp\_20 Q: 6

An experiment is carried out to measure the extension of a rubber band for different loads.

The results are shown below.

load / N	0	1.0	2.0	3.0
length / cm	15.2	16.2		18.6
extension / cm	0	1.0	2.1	3.4

Which figure is missing from the table?

- A** 17.2      **B** 17.3      **C** 17.4      **D** 17.6

26. 0625\_p20\_qp\_20 Q: 7

The diagram shows a satellite that is moving at a uniform rate in a circular orbit around the Earth.

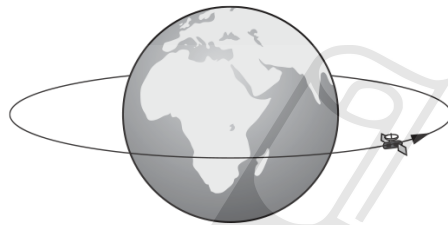

Which statement describes the motion of this satellite?

- A** It is accelerating because its speed is changing.  
**B** It is accelerating because its velocity is changing.  
**C** It is not accelerating but its speed is changing.  
**D** It is not accelerating but its velocity is changing.

27. 0625\_p20\_qp\_20 Q: 8

Which statement about an object moving in a straight line through air is correct?

- A** When it accelerates, the resultant force acting on it is zero.  
**B** When it moves at a steady speed, the air resistance acting on it is zero.  
**C** When it moves at a steady speed, the resultant force acting on it is zero.  
**D** When it moves, there is a resultant force acting on it.

1.5. FORCES

28. 0625\_p20\_qp\_20 Q: 9

A beam pivoted at one end has a force of 5.0N acting vertically upwards on it as shown. The beam is in equilibrium.

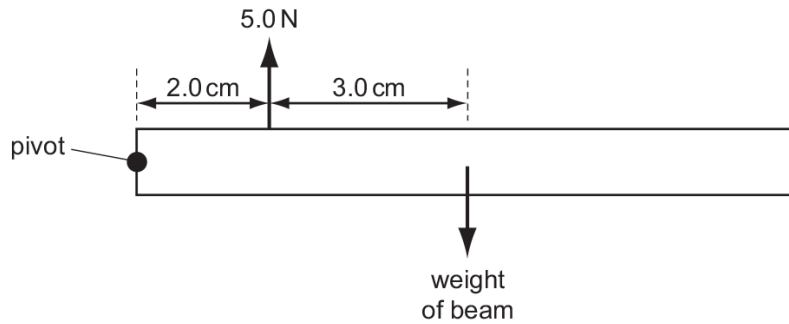

What is the weight of the beam?

- A** 2.0N      **B** 3.0N      **C** 3.3N      **D** 5.0N

29. 0625\_p20\_qp\_20 Q: 11

Which diagram shows two forces X and Y with their resultant force?

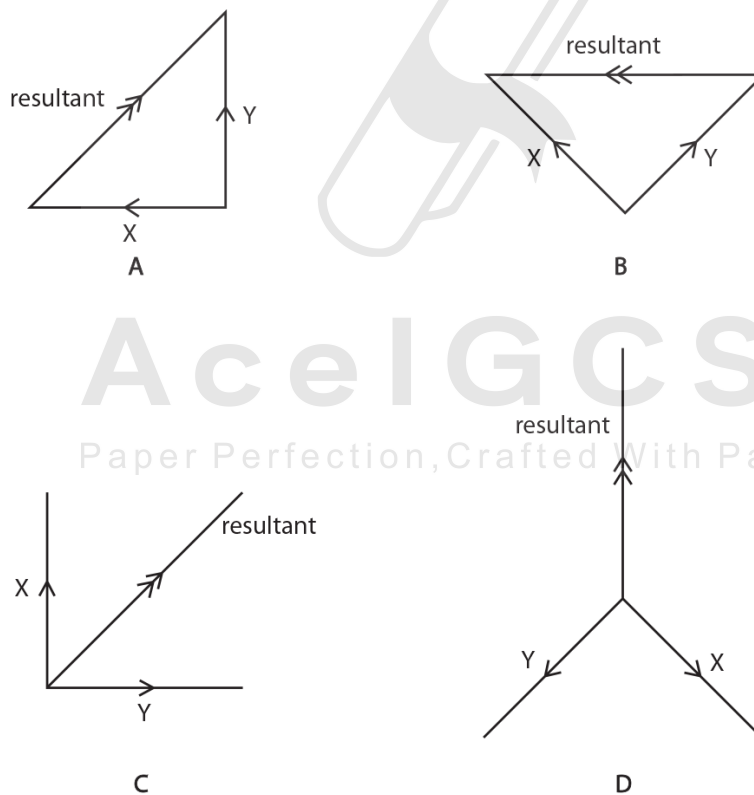

30. 0625\_s20\_qp\_21 Q: 4

Which statement correctly describes the effects of placing a heavy load in a car?

- A It is easier to accelerate the car and easier to bring the car to rest.
- B It is easier to accelerate the car but more difficult to bring the car to rest.
- C It is more difficult to accelerate the car and more difficult to bring the car to rest.
- D It is more difficult to accelerate the car but easier to bring the car to rest.

31. 0625\_s20\_qp\_21 Q: 7

The diagram shows a wooden beam PQ, of negligible weight, which is attached to a wall by a hinge at P and kept in a horizontal position by a vertical rope attached at Q.

The beam is 3.0 m in length.

A man of weight 800 N walks along the beam from P to Q.

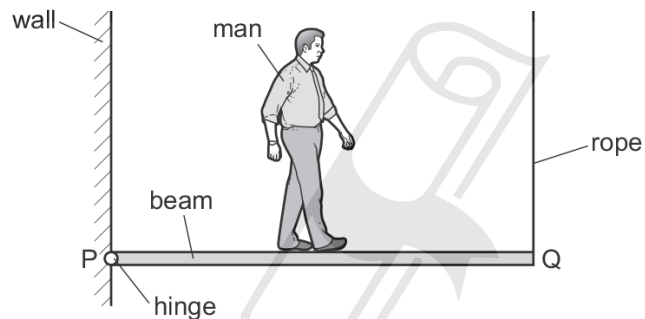

What is the distance of the man from P when the tension in the rope at Q becomes equal to 500 N?

- A 0.53 m
- B 1.1 m
- C 1.9 m
- D 2.5 m

32. 0625\_s20\_qp\_21 Q: 8

Which quantity is a vector?

- A acceleration
- B distance
- C speed
- D mass

1.5. FORCES

33. 0625\_s20\_qp\_21 Q: 9

An object of mass 1.2 kg is moving with a velocity of 2.0 m/s when it is acted on by a force of 4.0 N. The velocity of the object increases to 5.0 m/s.

For what period of time does the force act on the object?

- A** 0.90 s      **B** 1.1 s      **C** 1.5 s      **D** 3.6 s
- 

34. 0625\_s20\_qp\_22 Q: 7

A satellite orbits the Earth at constant speed in a circular orbit.

Which statement is correct?

- A** The resultant force on the satellite is zero.  
**B** The resultant force on the satellite is towards the Earth.  
**C** The resultant force on the satellite is away from the Earth.  
**D** The resultant force on the satellite is in the direction of motion.
- 

35. 0625\_s20\_qp\_22 Q: 8

Two forces P and Q act on an object.

Which diagram shows the resultant of these two forces?

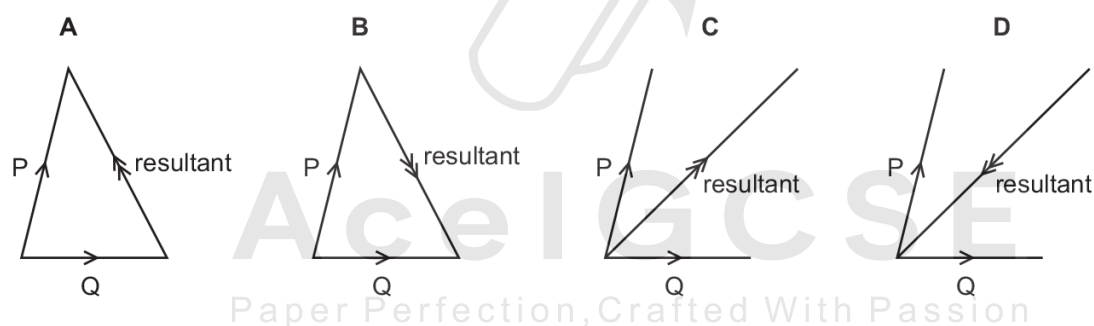

36. 0625\_s20\_qp\_23 Q: 7

Which moving object has a resultant force acting on it?

- A** a diver rising vertically through water at constant speed  
**B** an aircraft circling an airport at constant speed  
**C** a parachutist descending vertically at terminal velocity  
**D** a train going up a straight slope at constant speed
-

37. 0625\_s20\_qp\_23 Q: 8

Which quantity is **not** a vector?

- A acceleration
  - B temperature
  - C velocity
  - D weight
- 

38. 0625\_w20\_qp\_21 Q: 7

A uniform plank rests on a pivot at its centre.

Two children P and Q sit on the plank in the positions shown.

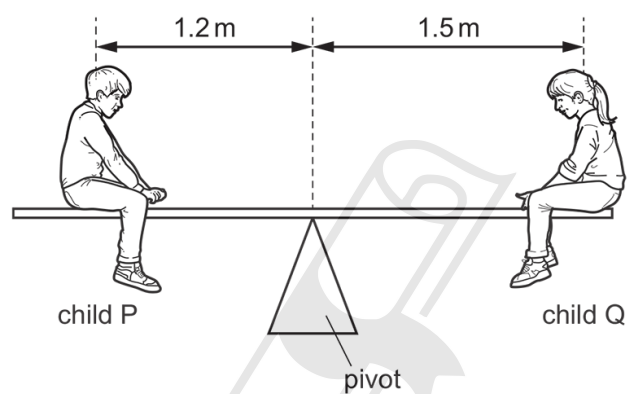

The mass of child P is 25 kg.

The plank is balanced.

What is the mass of child Q?

- A 20 kg
  - B 25 kg
  - C 31 kg
  - D 45 kg
-

1.5. FORCES

39. 0625\_w20\_qp\_21 Q: 8

The diagram shows three forces acting on an object.

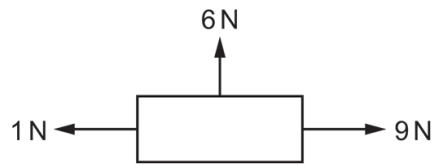

What is the value of the resultant force acting on the object?

- A** 2 N            **B** 10 N            **C** 14 N            **D** 16 N

---

40. 0625\_w20\_qp\_21 Q: 10

A stone is dropped from rest at a height of 2.0 m above the surface of a planet.

The planet has no atmosphere.

The speed of the stone just before reaching the surface of the planet is 3.8 m/s.

What is the acceleration of free fall on the planet?

- A** zero            **B** 1.9 m/s<sup>2</sup>            **C** 3.6 m/s<sup>2</sup>            **D** 7.2 m/s<sup>2</sup>

---

Paper Perfection, Crafted With Passion

41. 0625\_w20\_qp\_22 Q: 3

A concrete block falls vertically from an aeroplane.

The concrete block falls into the sea and sinks.

Which graph shows the vertical motion of the concrete block?

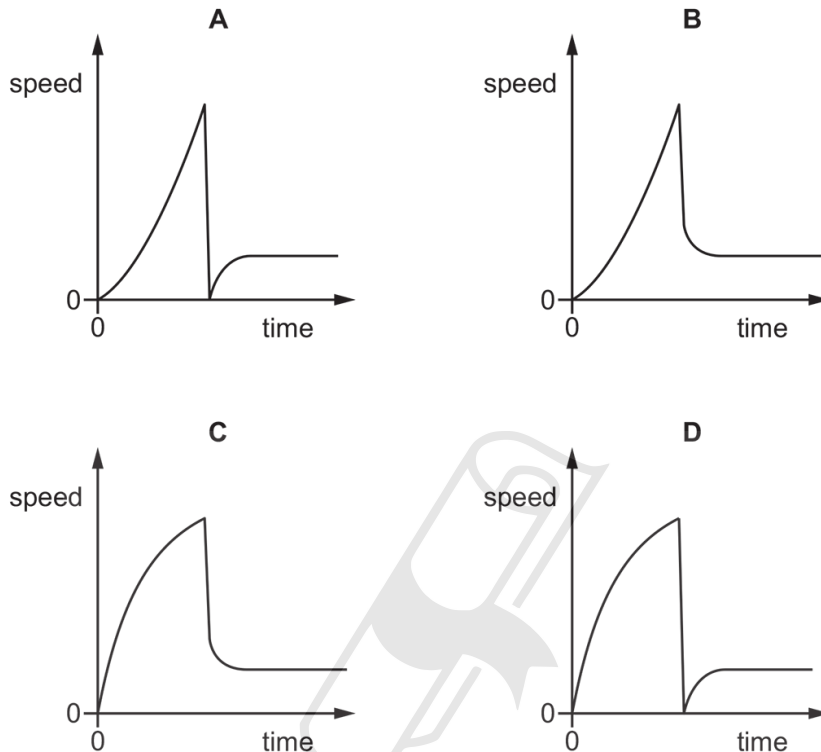

42. 0625\_w20\_qp\_22 Q: 7

The diagram shows a beam lying on the ground. End Q is lifted from the ground by the force  $F$ .

End P of the beam remains on the ground.

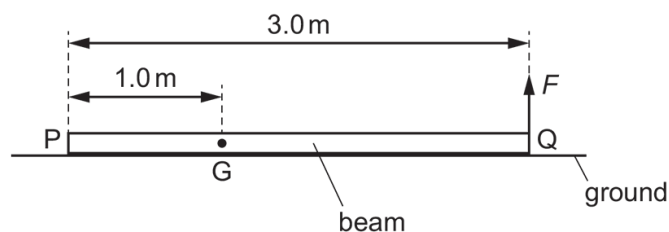

The length of the beam is 3.0 m and its weight is 600 N.

The centre of mass of the beam at G is 1.0 m from end P.

What is the size of the force  $F$  when it just raises end Q from the ground?

- A** 200 N      **B** 300 N      **C** 400 N      **D** 600 N

1.5. FORCES

43. 0625\_w20\_qp\_22 Q: 8

The diagram shows a stand. The stand holds a heavy mass above the bench.

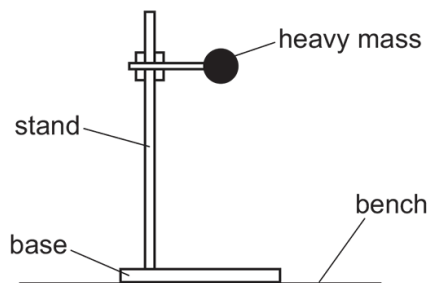

Which two changes would definitely make the stand more stable?

- A Lower the mass and make the base narrower.
  - B Lower the mass and make the base wider.
  - C Raise the mass and make the base narrower.
  - D Raise the mass and make the base wider.
- 

44. 0625\_w20\_qp\_23 Q: 7

The diagram shows a car moving along a road.

The force due to the engine is 1500 N and the total drag force is 200 N.



What is the motion of the car?

- A constant speed
  - B decreasing speed
  - C increasing speed
  - D reversing
-

45. 0625\_w20\_qp\_23 Q: 8

The diagram shows a trolley used to transport a load of 400 N.

A force  $F$  vertically downwards is needed to balance the trolley as shown.

The centre of mass of the trolley is vertically above the pivot.

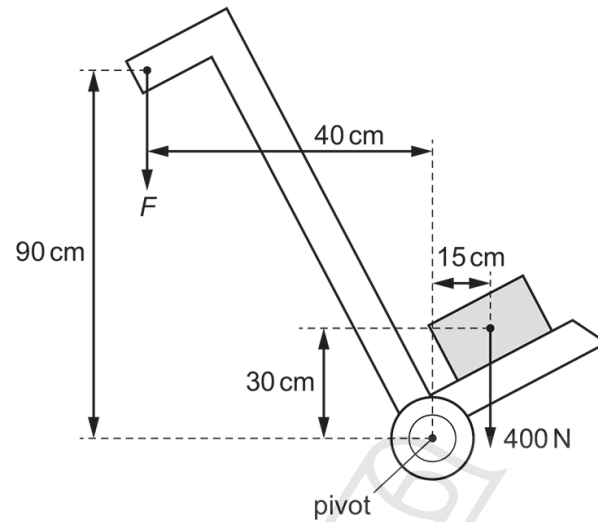

What is the value of  $F$ ?

- A** 133 N      **B** 150 N      **C** 300 N      **D** 400 N
-

1.5. FORCES

46. 0625\_m19\_qp\_22 Q: 7

The extension/load graph for a spring is shown. The unstretched length of the spring is 15.0 cm.

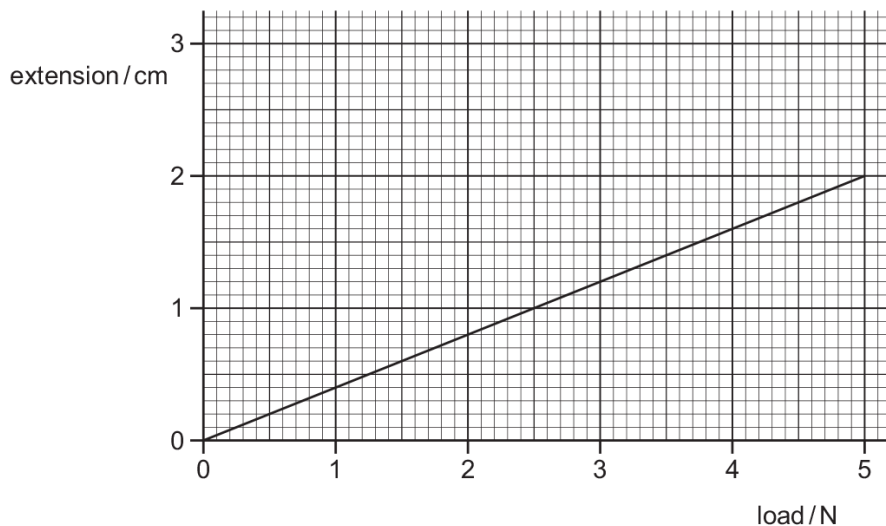

When an object of unknown weight is suspended on the spring, the length of the spring is 16.4 cm.

What is the weight of the object?

- A** 0.55 N      **B** 0.67 N      **C** 3.5 N      **D** 4.1 N
- 

47. 0625\_m19\_qp\_22 Q: 8

A box of mass 2.0 kg is pulled across the floor by a force of 6.0 N.

The frictional force acting on the box is 1.0 N.

What is the acceleration of the box?

- A** 0.40 m/s<sup>2</sup>      **B** 2.5 m/s<sup>2</sup>      **C** 3.0 m/s<sup>2</sup>      **D** 3.5 m/s<sup>2</sup>
- 

48. 0625\_m19\_qp\_22 Q: 9

Which moving body has a resultant force acting on it?

- A** a diver rising vertically through water at constant speed  
**B** an aircraft circling an airport at constant speed  
**C** a train going up a straight incline at constant speed  
**D** a parachutist descending vertically at terminal velocity
-

49. 0625\_s19\_qp\_21 Q: 6

A student wishes to determine the spring constant of a spring where it obeys Hooke's law.

Different loads are hung from the spring and its length is measured for each different load.

The table shows the results of the experiment.

weight of load / N	0	2.0	4.0	5.0
length of spring / cm	12	20	28	38

What is the value of the spring constant of the spring?

- A** 0.13 N/cm    **B** 0.14 N/cm    **C** 0.19 N/cm    **D** 0.25 N/cm
- 

50. 0625\_s19\_qp\_21 Q: 7

A mass of 20 kg is held stationary by a rope passing over a frictionless pulley.

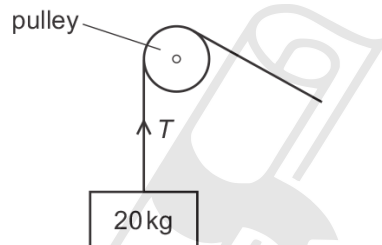

What is the tension  $T$  in the rope?

- A** 10 kg    **B** 20 kg    **C** 100 N    **D** 200 N
- 

**AceIGCSE**  
Paper Perfection, Crafted With Passion

1.5. FORCES

51. 0625\_s19\_qp\_21 Q: 8

A boat starts moving across a river at velocity  $v$  perpendicular to the river bank.

The boat encounters a current along the river of velocity  $u$ , as shown.

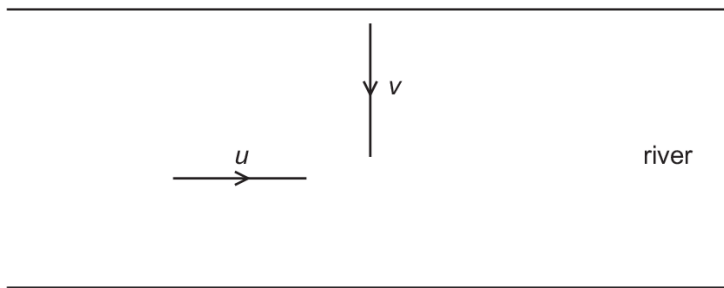

Which vector diagram shows the resultant velocity  $r$  of the boat?

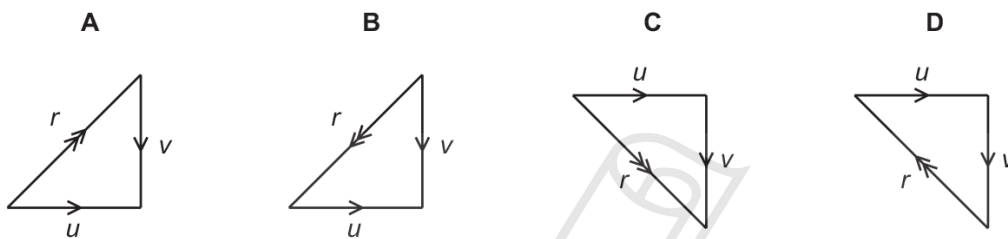

52. 0625\_s19\_qp\_22 Q: 6

An experiment is done to determine the spring constant for a spring.

Different loads are hung from the spring and its length is measured for each different load.

The graph shows how its length varies with load.

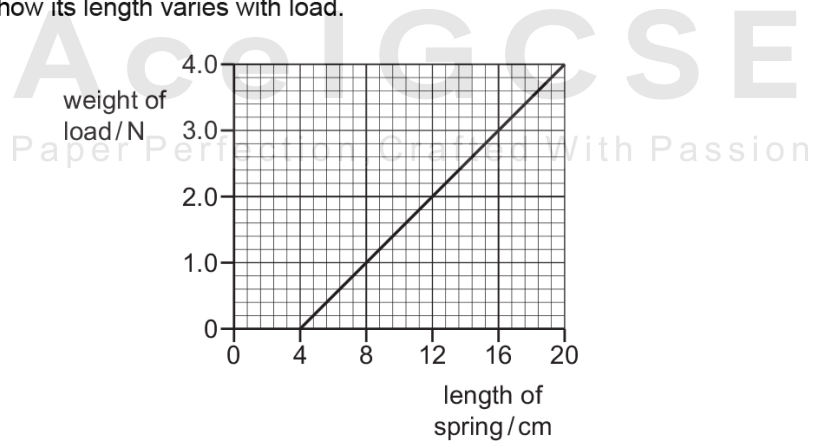

What is the value of the spring constant?

- A** 0.20 N/cm    **B** 0.25 N/cm    **C** 4.0 N/cm    **D** 5.0 N/cm

53. 0625\_s19\_qp\_22 Q: 7

A beam is pivoted at its centre of mass.

It is acted upon by two forces, 10 N and 5.0 N, as shown.

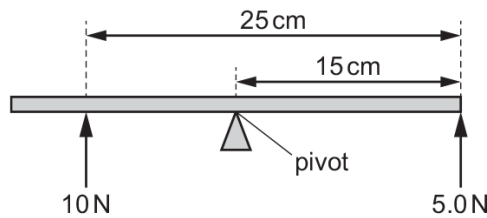

What is the resultant moment about the pivot?

- A 25 N cm anticlockwise
- B 25 N cm clockwise
- C 175 N cm anticlockwise
- D 175 N cm clockwise

54. 0625\_s19\_qp\_22 Q: 8

Which object is in equilibrium?

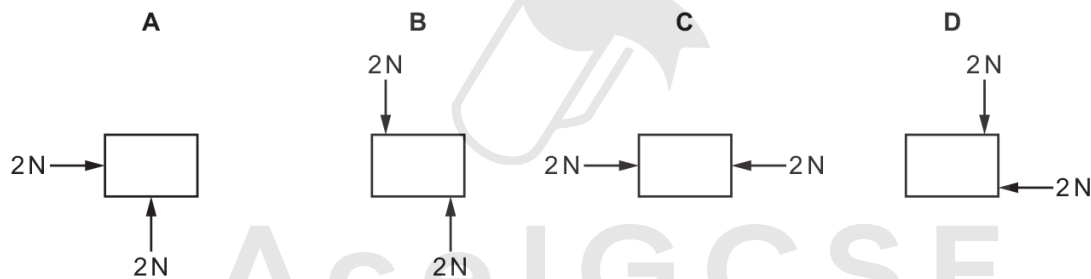

55. 0625\_s19\_qp\_23 Q: 4

On Earth, a spring stretches by 5.0 cm when a mass of 3.0 kg is suspended from one end.

The gravitational field strength on the Moon is  $\frac{1}{6}$  of that on Earth.

Which mass, on the Moon, would stretch the spring by the same extension?

- A 0.50 kg
- B 3.0 kg
- C 5.0 kg
- D 18 kg

1.5. FORCES

56. 0625\_s19\_qp\_23 Q: 6

An experiment is carried out to determine the spring constant for a spring that obeys Hooke's law.

A load is hung from the spring and the extension of the spring is measured.

Which calculation is used to calculate the spring constant?

- A  $\frac{\text{extension}}{\text{mass of the load}}$
  - B  $\frac{\text{extension}}{\text{weight of the load}}$
  - C  $\frac{\text{mass of the load}}{\text{extension}}$
  - D  $\frac{\text{weight of the load}}{\text{extension}}$
- 

57. 0625\_s19\_qp\_23 Q: 7

A car is driven from rest on a long straight road. The car engine exerts a constant driving force.

The diagram shows the horizontal forces acting on the car. The resistive forces are proportional to the speed of the car.

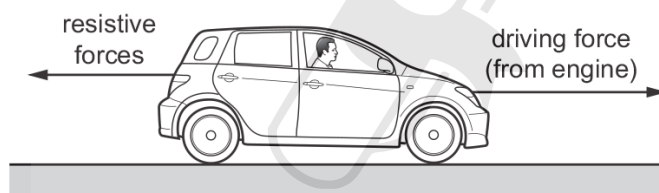

Why does the car eventually reach a maximum speed?

- A The resistive forces decrease to make the acceleration of the car negative.
  - B The resistive forces decrease to make the acceleration of the car zero.
  - C The resistive forces increase to make the acceleration of the car negative.
  - D The resistive forces increase to make the acceleration of the car zero.
-

58. 0625\_s19\_qp\_23 Q: 8

A beam of weight 6.0 N is suspended from two strings P and Q.

String P is 30 cm from the left-hand end of the beam, as shown. String Q is not shown.

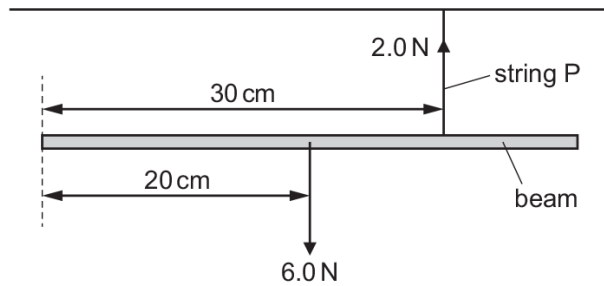

The tension in string P is 2.0 N.

What is the tension in string Q and where is it attached so that the beam is in equilibrium?

- A 4.0 N at 10.0 cm from the left-hand end
- B 4.0 N at 15.0 cm from the left-hand end
- C 6.0 N at 10.0 cm from the left-hand end
- D 8.0 N at 7.5 cm from the left-hand end

59. 0625\_w19\_qp\_21 Q: 6

A car is travelling around a circular track at a constant speed, as shown.

In which direction is the resultant force on the car?

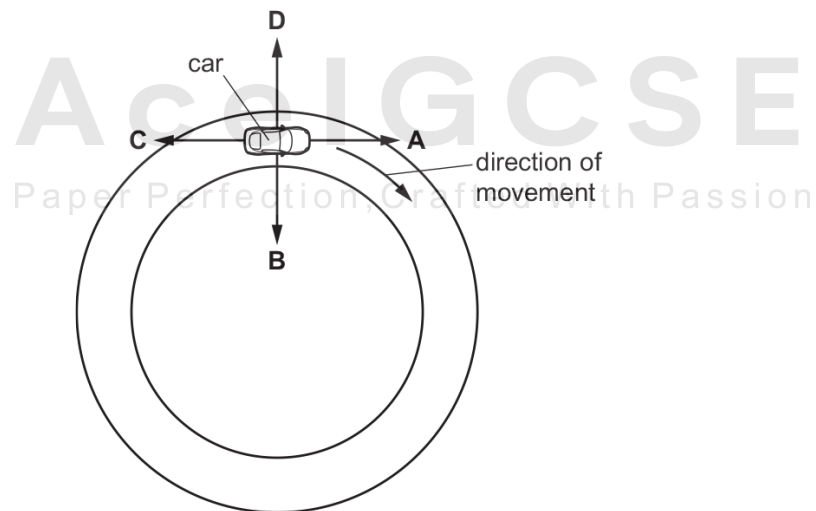

1.5. FORCES

60. 0625\_w19\_qp\_21 Q: 7

Two forces  $P$  and  $Q$  act on a metre rule as shown. The metre rule is pivoted at one end. The rule starts to rotate in a clockwise direction.

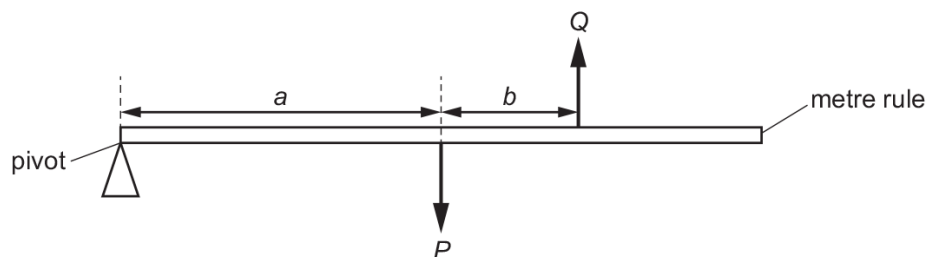

Which statement is correct?

- A  $P$  equals  $Q$
- B  $P$  is less than  $Q$
- C  $(P \times a)$  is equal to  $(Q \times b)$
- D  $(P \times a)$  is greater than  $(Q \times (a + b))$

61. 0625\_w19\_qp\_21 Q: 8

Which statement gives a complete description of any object that is in equilibrium?

- A There are no forces acting.
- B There is no resultant force.
- C There is no resultant force and no resultant turning effect.
- D There is no resultant turning effect.

62. 0625\_w19\_qp\_22 Q: 4

A box is placed on the ground. An upward force of 15N is needed to lift the box at constant speed.

Which row correctly describes the box?

	mass of the box	weight of the box
A	1.5 kg	15 N
B	15 N	1.5 kg
C	15 N	150 kg
D	150 kg	15 N

63. 0625\_w19\_qp\_22 Q: 6

A hook is used to lift a metal plate, as shown.

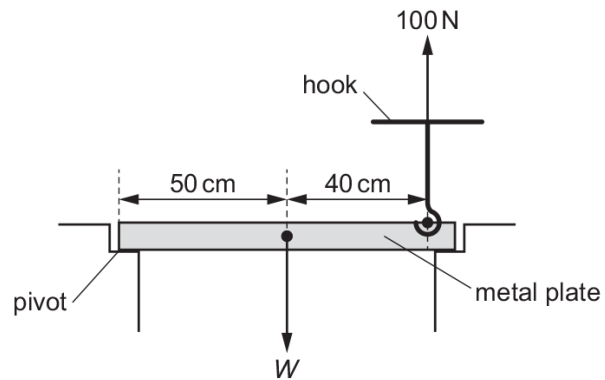

An upward force of 100 N is needed to lift the metal plate about the pivot, as shown.

What is the weight  $W$  of the metal plate?

- A** 80 N      **B** 100 N      **C** 180 N      **D** 225 N
- 

64. 0625\_w19\_qp\_22 Q: 7

What is the unit of the moment of a force?

- A** N      **B** N/kg      **C** N/m      **D** Nm
-

1.5. FORCES

65. 0625\_w19\_qp\_22 Q: 8

A ship travels due North through still water at a speed of 20 m/s.

It enters a channel where there is a current in the water from West to East. The speed of the current is 20 m/s.

Which diagram shows the resultant velocity  $v$  of the ship?

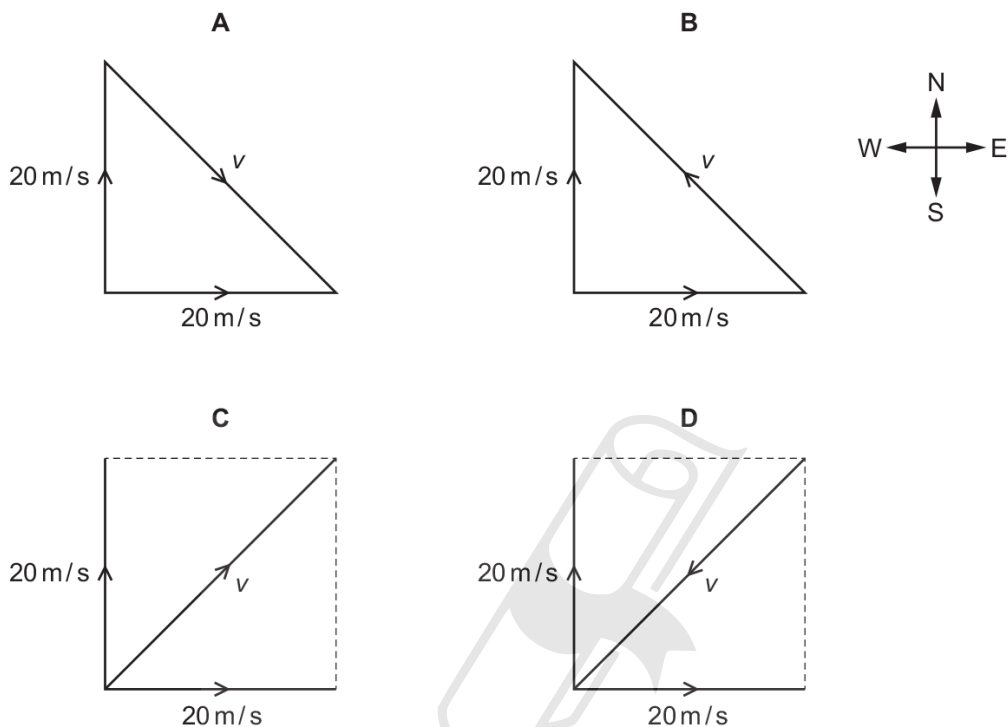

66. 0625\_w19\_qp\_23 Q: 5

A box of mass 2.0 kg is pulled across a horizontal floor by a force of 6.0 N.

The frictional force acting on the box is 1.0 N.

What is the acceleration of the box?

- A** 0.40 m/s<sup>2</sup>    **B** 2.5 m/s<sup>2</sup>    **C** 3.0 m/s<sup>2</sup>    **D** 3.5 m/s<sup>2</sup>

67. 0625\_w19\_qp\_23 Q: 7

The diagram shows a uniform metre rule. The rule is pivoted at its mid-point. A downward force of 4.0 N acts on the rule at the 5 cm mark. The rule is held by a string at the 30 cm mark. The rule is in equilibrium.

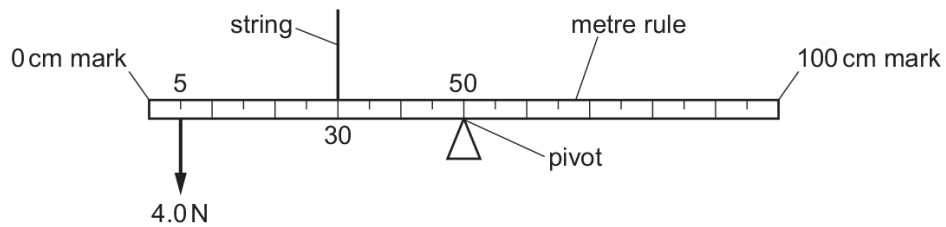

What is the upward force that the string exerts on the rule?

- A** 0.67 N      **B** 4.0 N      **C** 6.0 N      **D** 9.0 N

68. 0625\_w19\_qp\_23 Q: 8

A ship sails due North at a speed of 20 m/s. A current in the water begins to move from East to West. The speed of this current is 20 m/s.

What is the magnitude of the resultant velocity of the ship?

- A** 0 m/s      **B** 20 m/s      **C** 28 m/s      **D** 40 m/s

69. 0625\_m18\_qp\_22 Q: 4

The diagram shows a bird in flight. The bird is flying in a horizontal direction to the right.

In which direction does air resistance act on the bird?

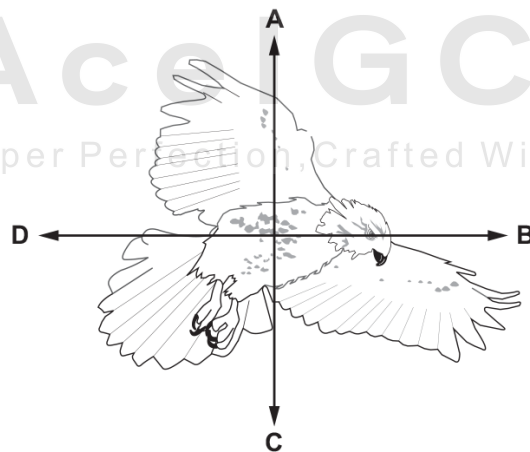

1.5. FORCES

70. 0625\_m18\_qp\_22 Q: 8

A uniform rod XY of weight 2.0 N has a length of 80 cm.

The rod is suspended by a thread 20 cm from end X. A weight of 5.0 N is suspended from end X.

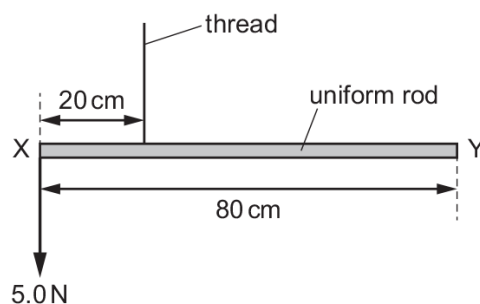

A student hangs a 6.0 N weight on the rod so that it is in equilibrium.

What is the distance of the 6.0 N weight from end X?

- A** 6 cm      **B** 10 cm      **C** 26 cm      **D** 30 cm
- 

71. 0625\_m18\_qp\_22 Q: 9

A wooden plank rests in equilibrium on two rocks on opposite sides of a narrow stream.

Three forces  $P$ ,  $Q$  and  $R$  act on the plank.

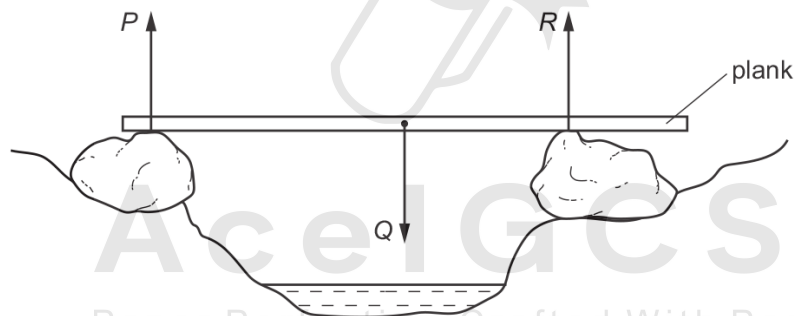

How are the sizes of the forces related?

- A**  $P + Q = R$   
**B**  $P + R = Q$   
**C**  $P = Q = R$   
**D**  $P = Q + R$
-

72. 0625\_s18\_qp\_21 Q: 6

A force acting on a moving ball causes its motion to change. This force stays constant.

What makes the force produce a greater change in the motion of the ball?

- A decreasing the total mass of the ball
- B increasing the temperature of the ball
- C using a ball with a hollow centre but the same mass
- D using a different material for the ball so that it has a lower density but the same mass

73. 0625\_s18\_qp\_21 Q: 7

A balloon and a mass are attached to a rod that is pivoted at P.

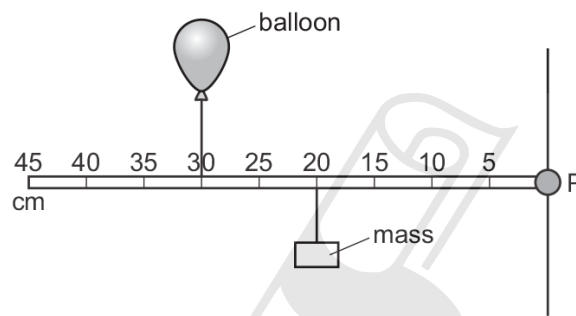

The balloon is filled with helium, a gas less dense than air, so that it applies an upward force on the rod.

The rod is horizontal and stationary.

Which action causes the rod to rotate clockwise?

- A Move both the balloon and mass 10 cm to the left.
- B Move both the balloon and mass 10 cm to the right.
- C Move both the balloon and mass to the 25 cm mark.
- D Move the balloon to the 20 cm mark and the mass to the 30 cm mark.

### 1.5. FORCES

74. 0625\_s18\_qp\_21 Q: 8

A car is moving in a straight line on a level road. Its engine provides a forward force on the car. A second force of equal size acts on the car due to resistive forces.

Which statement describes what happens?

- A The car changes direction.
  - B The car moves at a constant speed.
  - C The car slows down.
  - D The car speeds up.
- 

75. 0625\_s18\_qp\_22 Q: 6

An object decelerates from 25.0 m/s to 5.0 m/s in a time of 4.0 s.

It has a mass of 50 kg.

What is the resultant force on the object?

- A 0.63 N
  - B 10 N
  - C 250 N
  - D 4000 N
- 

76. 0625\_s18\_qp\_22 Q: 7

A beam is pivoted at one end, as shown.

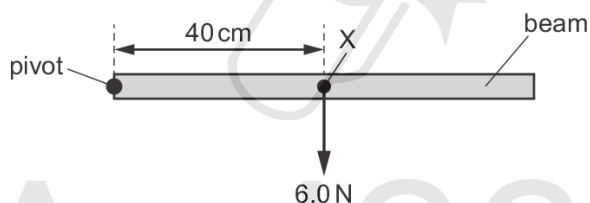

The beam weighs 6.0 N and its weight acts at a point X, 40 cm from the pivot.

A force of 4.0 N is applied to the beam causing it to balance horizontally.

In which direction and where is the 4.0 N force applied?

- A downwards at 20 cm to the left of X
  - B downwards at 20 cm to the right of X
  - C upwards at 20 cm to the left of X
  - D upwards at 20 cm to the right of X
-

77. 0625\_s18\_qp\_22 Q: 8

A spacecraft is travelling in space with no resultant force and no resultant moment acting on it.

Which statement about the spacecraft is correct?

- A Its direction is changing.
  - B It is in equilibrium.
  - C Its speed is decreasing.
  - D Its speed is increasing.
- 

78. 0625\_s18\_qp\_23 Q: 6

A load is hung from a steel wire. The load is increased.

The length of the wire increases until the limit of proportionality is reached.

The load is now increased slightly.

What happens?

- A The extension of the wire increases and the wire no longer obeys Hooke's law.
  - B The extension of the wire decreases and the wire no longer obeys Hooke's law.
  - C The extension of the wire increases and it obeys Hooke's law.
  - D The extension of the wire decreases and it obeys Hooke's law.
- 

79. 0625\_s18\_qp\_23 Q: 7

The diagram shows a uniform metre rule pivoted at the 30 cm mark.

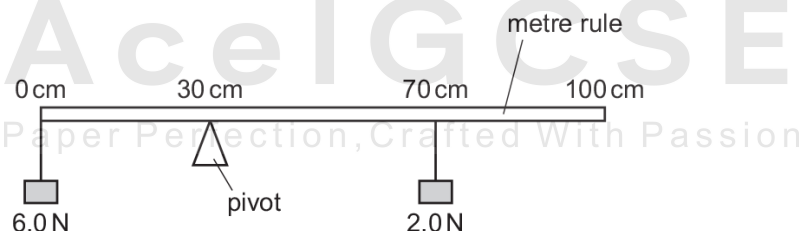

The rule balances when a weight of 6.0 N is hanging from the zero mark and a weight of 2.0 N is hanging from the 70 cm mark.

What is the weight of the rule?

- A 2.0 N
  - B 5.0 N
  - C 6.0 N
  - D 13.0 N
-

### 1.5. FORCES

80. 0625\_s18\_qp\_23 Q: 8

An astronaut orbits the Earth in a space station.

Which is a vector quantity?

- A the mass of the astronaut
  - B the speed of the satellite
  - C the temperature inside the satellite
  - D the weight of the astronaut
- 

81. 0625\_w18\_qp\_21 Q: 4

A helium balloon is tied to a top-pan balance. A metal block of mass 100g is placed on the balance. The reading on the balance is 91 g.

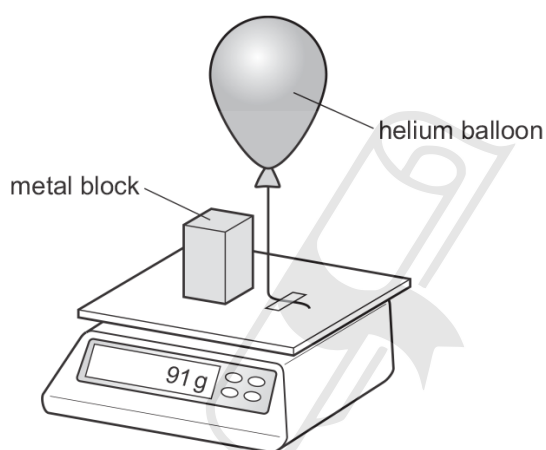

Which statement can be deduced from this experiment?

- A The balloon exerts a downward force of 0.09 N on the top-pan balance.
  - B The helium has a mass of  $-9\text{g}$ .
  - C The helium has a mass of  $+9\text{g}$ .
  - D The resultant downward force on the top-pan balance is 0.91 N.
- 

82. 0625\_w18\_qp\_21 Q: 7

Which quantities are both vectors?

- A acceleration and force
  - B acceleration and pressure
  - C density and force
  - D density and pressure
-

83. 0625\_w18\_qp\_22 Q: 6

The graph shows how the length of a spring changes when the stretching force is increased.

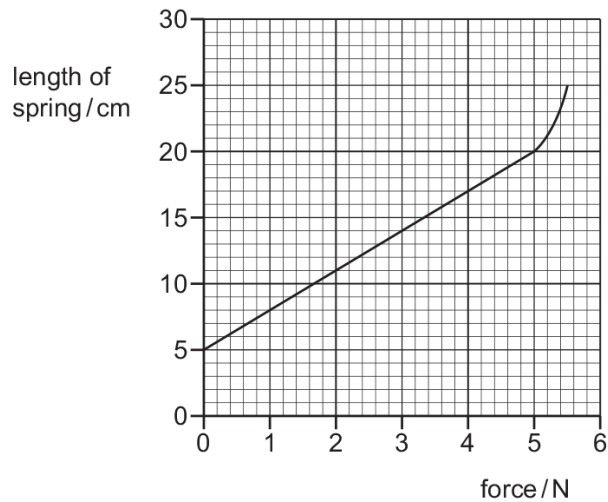

In the Hooke's law region, what is the spring constant for this spring?

- A** 0.20 N/cm    **B** 0.22 N/cm    **C** 0.28 N/cm    **D** 0.33 N/cm

84. 0625\_w18\_qp\_22 Q: 7

Point X is the centre of mass of a lamina in the shape of a triangle with sides of equal length. The top of the triangle is cut off along the dotted line shown.

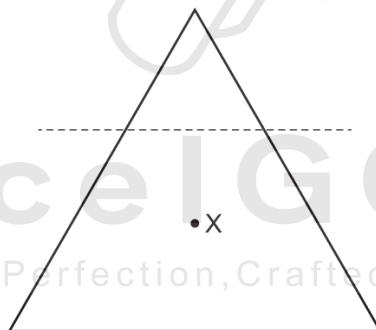

What happens to the centre of mass, X?

- A** moves towards the bottom of the page  
**B** moves to the left  
**C** moves to the right  
**D** moves towards the top of the page

1.5. FORCES

85. 0625\_w18\_qp\_23 Q: 6

An object accelerates from 10 m/s to 30 m/s in 4.0 seconds.

The accelerating force is 150 N.

What is the mass of the object?

- A** 0.033 kg      **B** 5.0 kg      **C** 7.5 kg      **D** 30 kg
- 

86. 0625\_w18\_qp\_23 Q: 7

The diagram shows a uniform bar of length 120 cm and weight  $W$ . The bar is pivoted at a point 40 cm from the left end of the bar.

A load of  $\frac{W}{2}$  is suspended from the right-hand end of the bar.

A downward force  $F$  is applied to the left-hand end of the bar to keep it in equilibrium.

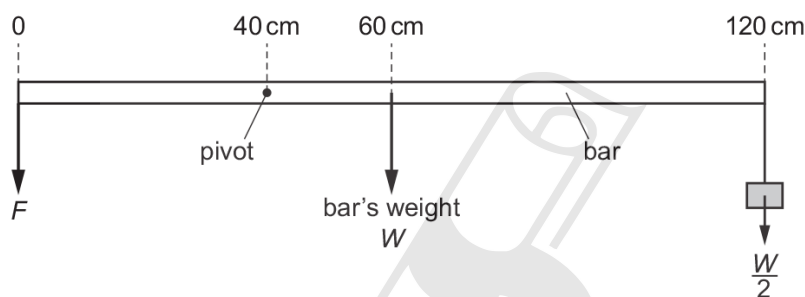

What is the magnitude of force  $F$ ?

- A**  $\frac{W}{2}$       **B**  $W$       **C**  $\frac{3W}{2}$       **D**  $2W$
- 

87. 0625\_m17\_qp\_22 Q: 6

A skydiver jumps from a stationary helicopter and reaches a steady vertical speed. She then opens her parachute.

Which statement about the falling skydiver is correct?

- A** As her parachute opens, her acceleration is upwards.  
**B** As she falls at a steady speed with her parachute open, her weight is zero.  
**C** When she accelerates, the resultant force on her is zero.  
**D** When she falls at a steady speed, air resistance is zero.
-

88. 0625\_m17\_qp\_22 Q: 7

A car moves in a circular path as it turns a corner on a horizontal road.

The car moves at constant speed.

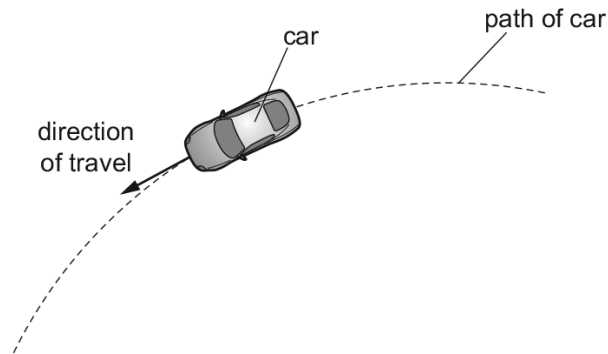

Which description of the forces acting on the car is correct?

- A All the forces are balanced as the car is moving at constant speed.
  - B The forces are unbalanced and the resultant force acts away from the centre of the circle.
  - C The forces are unbalanced and the resultant force acts towards the centre of the circle.
  - D The forces are unbalanced and the resultant force is in the direction of travel of the car.
- 

89. 0625\_s17\_qp\_21 Q: 3

A skydiver reaches terminal velocity. Then he opens his parachute.

What happens to the skydiver as the parachute opens?

- A There is a decrease in weight.
  - B There is acceleration upwards.
  - C There is an increase in speed.
  - D There is movement upwards.
-

1.5. FORCES

90. 0625\_s17\_qp\_21 Q: 6

A boat is travelling at a steady speed in a straight line across the surface of a lake.

Which statement about the boat is correct?

- A The resultant force on the boat is in the direction of motion.
- B The resultant force on the boat is in the opposite direction to its motion.
- C The resultant force on the boat is vertically downwards.
- D The resultant force on the boat is zero.

91. 0625\_s17\_qp\_21 Q: 7

A ball of weight 1.2 N drops through the air at terminal velocity.

A sudden gust of wind exerts a horizontal force of 0.5 N on the ball from the left.

Which diagram shows the resultant force on the ball while the wind is blowing?

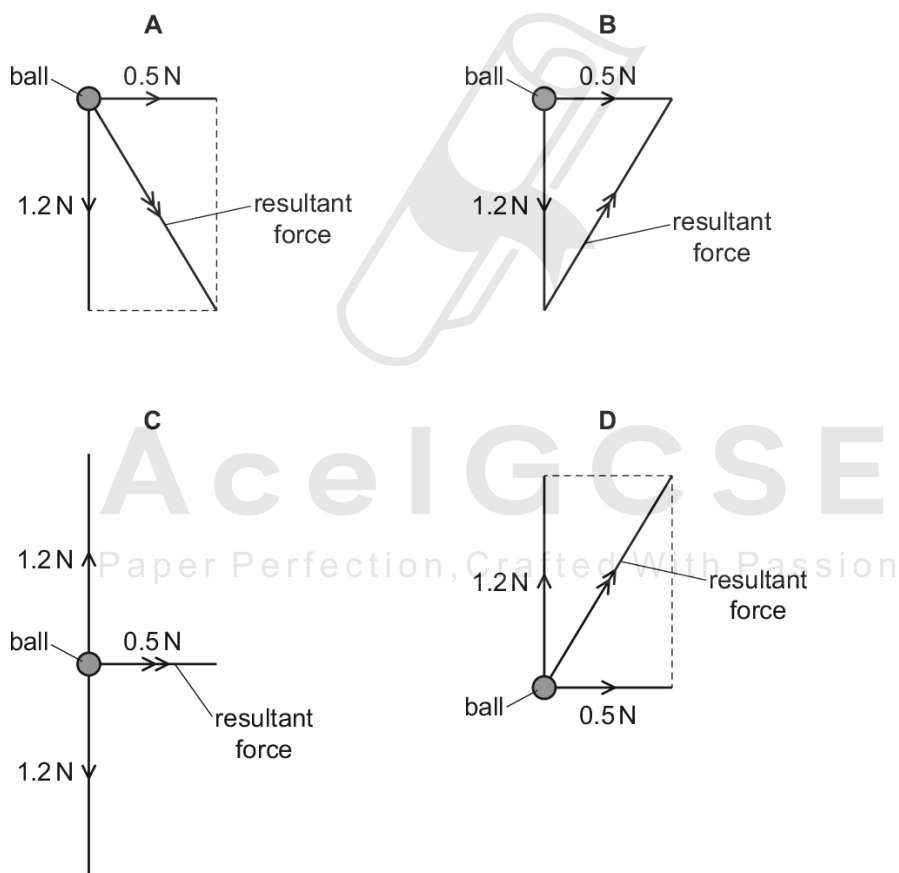

92. 0625\_s17\_qp\_21 Q: 8

The diagram shows a uniform bridge, 4.0 m long and weighing 10 000 N.

The bridge is pivoted at one end. A force at the other end gradually increases until the bridge begins to lift.

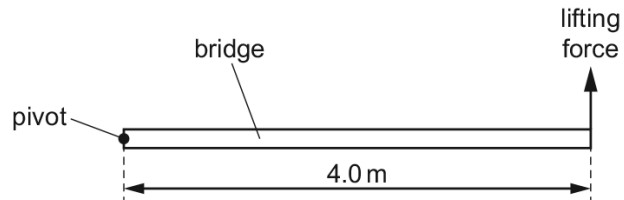

What is the lifting force as the bridge starts to move upwards?

- A** 2500 N      **B** 5000 N      **C** 10000 N      **D** 20000 N
- 

93. 0625\_s17\_qp\_22 Q: 4

In which pair are both quantities measured in newtons?

- A** force and pressure  
**B** force and weight  
**C** mass and pressure  
**D** mass and weight
- 

94. 0625\_s17\_qp\_22 Q: 6

A spring which obeys Hooke's Law has an unstretched length of 10 cm.

A load of 20 N is hung from the spring.

The new length of the spring is 36 cm.

What is the spring constant  $k$  of the spring?

- A** 0.56 N/cm      **B** 0.77 N/cm      **C** 1.3 N/cm      **D** 1.8 N/cm
-

1.5. FORCES

95. 0625\_s17\_qp\_22 Q: 7

A car travels forwards along a straight horizontal road. Only the horizontal forces acting on it are shown.



The length of each arrow represents the size of each force.

How do these forces affect the motion of the car?

- A The car moves at constant speed.
- B The car moves backwards.
- C The car slows down.
- D The car's forward speed increases.

---

96. 0625\_s17\_qp\_22 Q: 8

The diagram shows a wooden beam of weight 20N. The centre of mass of the beam is labelled *M*.

There is a pivot at one end of the beam. The beam is kept horizontal by an upward force, *F*.

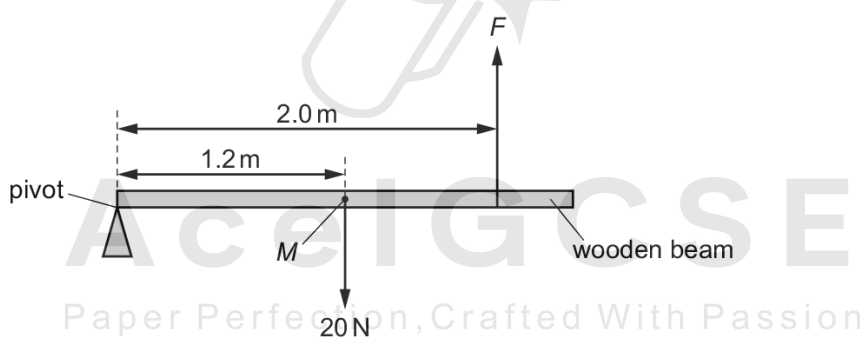

What is the magnitude of *F*?

- A 12 N
- B 20 N
- C 30 N
- D 33 N

97. 0625\_s17\_qp\_23 Q: 6

The diagram shows an object being acted upon by two forces.

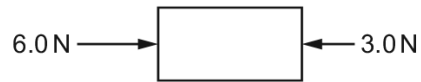

What is the size of the resultant force on the object?

- A 2.0 N      B 3.0 N      C 9.0 N      D 18 N

98. 0625\_s17\_qp\_23 Q: 7

The diagram shows a man holding a sack and barrow stationary. He applies a vertical force to the handle.

The centre of mass and the weight of the sack and barrow are shown. The wheel acts as a pivot.

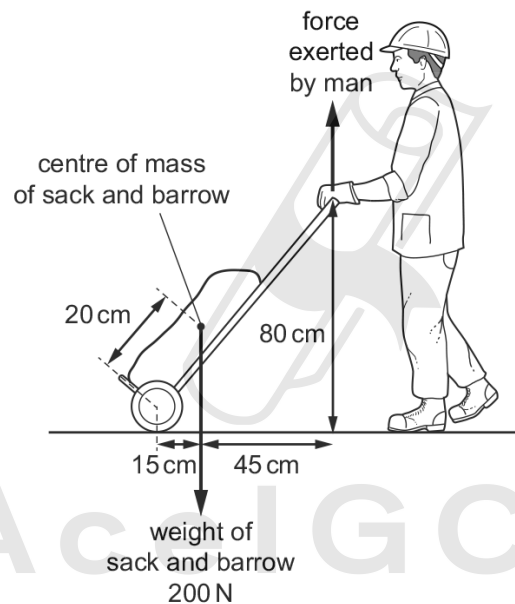

What is the magnitude of the vertical force exerted by the man?

- A 38 N      B 50 N      C 67 N      D 200 N

1.5. FORCES

99.0625\_s17\_qp\_23 Q: 8

The diagram shows the only two forces  $F_1$  and  $F_2$  acting on an object. The magnitude of each force is represented by the length of each arrow.

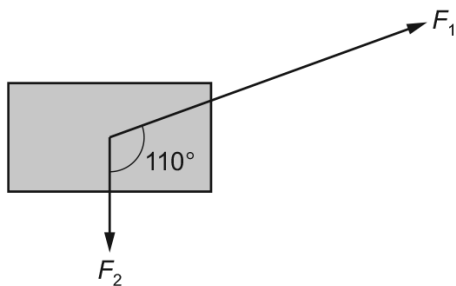

The resultant force acting on the object is  $R$ .

Which vector diagram shows how forces  $F_1$  and  $F_2$  add to produce  $R$ ?

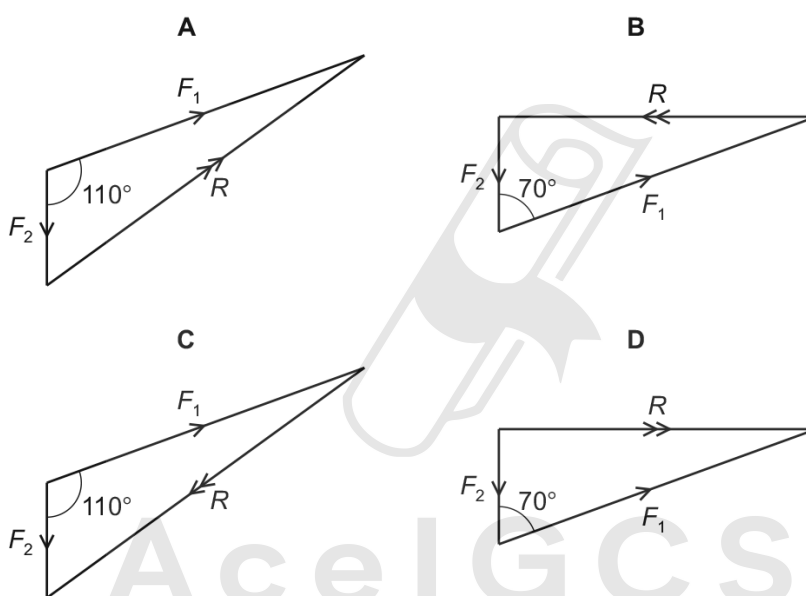

AceIGCSE  
Paper Perfection, Crafted With Passion

100. 0625\_w17\_qp\_21 Q: 6

A uniform beam XY is 100 cm long and weighs 4.0 N.

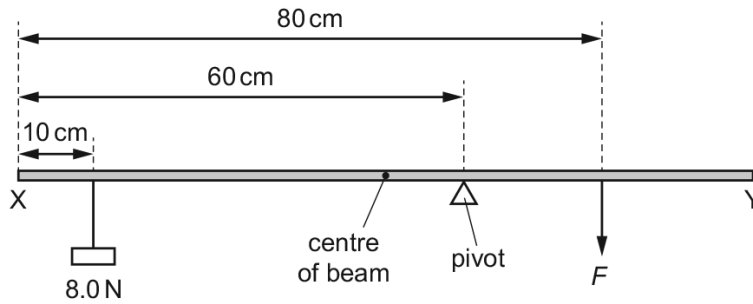

The beam rests on a pivot 60 cm from end X.

A load of 8.0 N hangs from the beam 10 cm from end X.

The beam is kept balanced by a force  $F$  acting on the beam 80 cm from end X.

What is the magnitude of force  $F$ ?

- A 8.0 N      B 18 N      C 22 N      D 44 N

101. 0625\_w17\_qp\_21 Q: 7

The diagrams show four table lamps resting on a table. The position of the centre of mass of each lamp is labelled X.

Which lamp is the most stable?

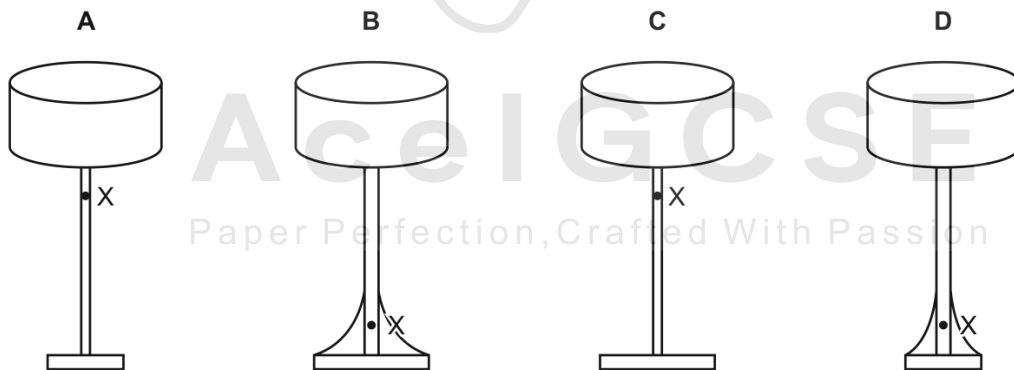

1.5. FORCES

102. 0625\_w17\_qp\_21 Q: 8

The diagram shows an incomplete scale drawing to find the resultant of two 10 N forces acting at a point in the directions shown.

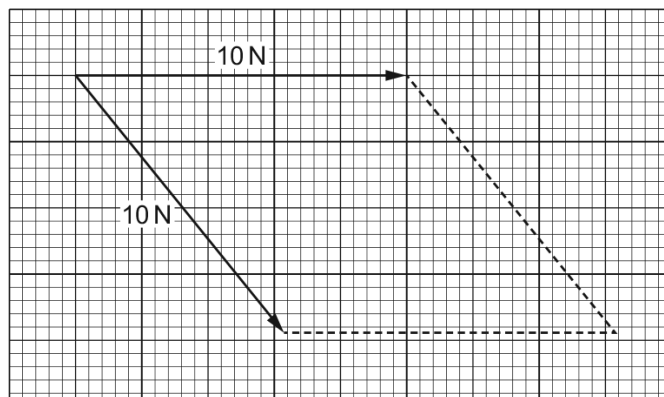

What is the magnitude of the resultant force?

- A** 7.5 N      **B** 8.6 N      **C** 18 N      **D** 20 N

103. 0625\_w17\_qp\_22 Q: 6

An object is pivoted at point P. A student ties a length of string to a peg on the object. He pulls the string with a force  $F$ .

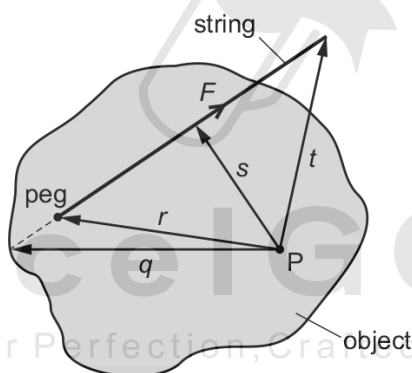

What is the moment of the force  $F$  about the point P?

- A**  $F \times q$       **B**  $F \times r$       **C**  $F \times s$       **D**  $F \times t$

104. 0625\_w17\_qp\_22 Q: 7

Each diagram shows a metal plate with four parallel forces acting on it. These are the only forces acting on the plates.

In which diagram is the plate in equilibrium?

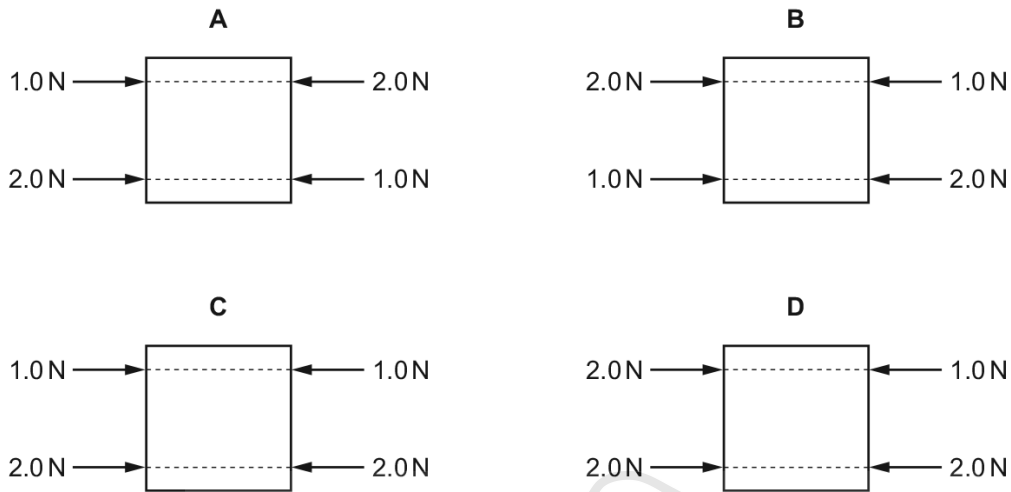

105. 0625\_w17\_qp\_23 Q: 3

The diagram shows the vertical forces acting on a ball as it falls vertically through the air. The ball does not reach terminal velocity.

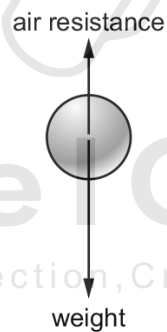

Which row describes what happens to the resultant force on the ball and what happens to the acceleration of the ball as it falls through the air?

	resultant force	acceleration
<b>A</b>	decreases	decreases
<b>B</b>	decreases	increases
<b>C</b>	increases	decreases
<b>D</b>	increases	increases

1.5. FORCES

106. 0625\_w17\_qp\_23 Q: 6

A pair of cutters is used to cut a rope.

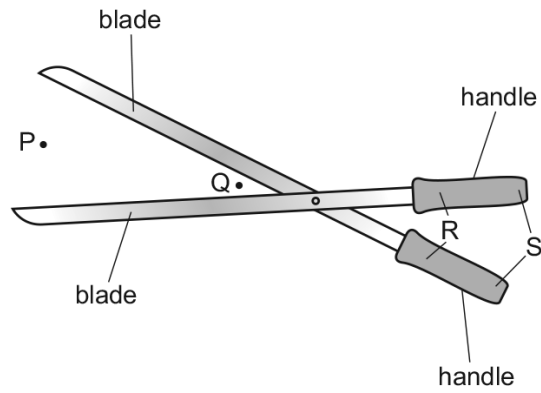

Where should the rope be positioned and at which labelled points should the hands be positioned to produce the greatest cutting force?

	rope positioned	hands positioned
<b>A</b>	P	R
<b>B</b>	P	S
<b>C</b>	Q	R
<b>D</b>	Q	S



107. 0625\_w17\_qp\_23 Q: 7

The lamp in the diagram is not very stable and falls over easily.

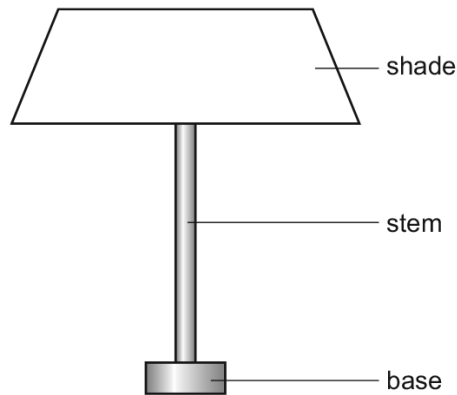

Which row shows changes that would definitely make the lamp more stable?

	base	centre of gravity
<b>A</b>	narrower	higher
<b>B</b>	narrower	lower
<b>C</b>	wider	higher
<b>D</b>	wider	lower

108. 0625\_m16\_qp\_22 Q: 6

The diagram shows an object moving at a constant speed in a circular path in the direction shown.

A force acts on the object to keep it in the circular path.

In which labelled direction does this force act, when the object is in the position shown?

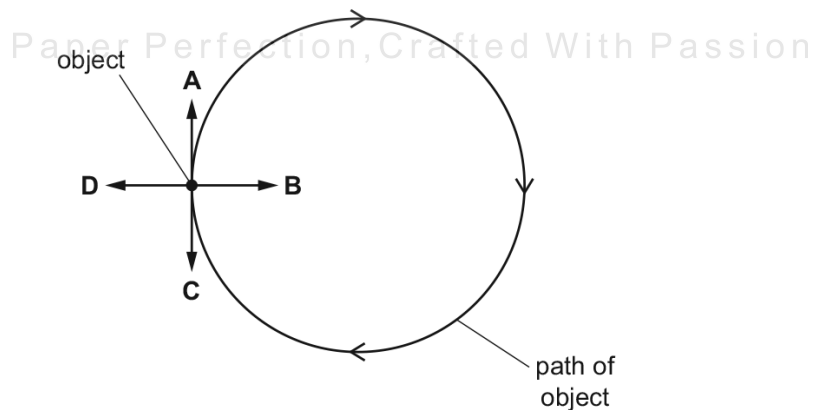

1.5. FORCES

109. 0625\_m16\_qp\_22 Q: 7

A spring obeys Hooke's law.

Which graph is obtained by plotting the extension of the spring against the load applied?

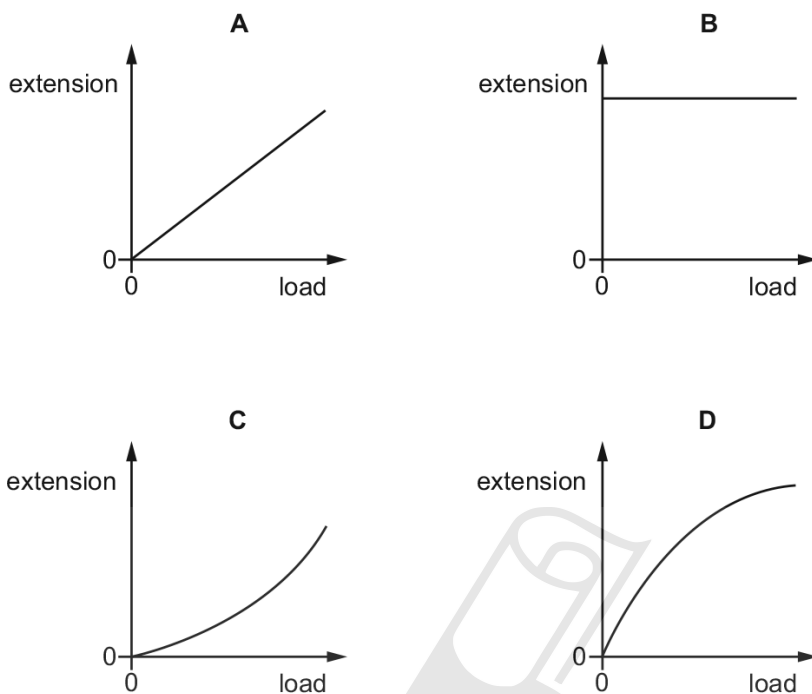

110. 0625\_m16\_qp\_22 Q: 8

Which is the value of a vector quantity?

- A 200 V
- B  $100 \text{ kg/m}^3$
- C 20 m/s, east
- D  $50 \text{ J/(kg}^\circ\text{C)}$

**AceIGCSE**  
Paper Perfection, Crafted With Passion

111. 0625\_p16\_qp\_20 Q: 6

An experiment is carried out to measure the extension of a rubber band for different loads.

The results are shown below.

load/N	0	1.0	2.0	3.0
length/cm	15.2	16.2		18.6
extension/cm	0	1.0	2.1	3.4

Which figure is missing from the table?

- A** 17.2      **B** 17.3      **C** 17.4      **D** 17.6

112. 0625\_p16\_qp\_20 Q: 7

The diagram shows a satellite that is moving at a uniform rate in a circular orbit around the Earth.

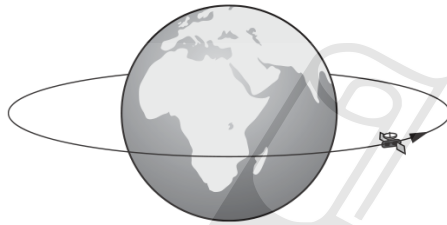

Which statement describes the motion of this satellite?

- A** It is accelerating because its speed is changing.  
**B** It is accelerating because its velocity is changing.  
**C** It is not accelerating but its speed is changing.  
**D** It is not accelerating but its velocity is changing.

AcelGCSE  
Paper Perfection, Crafted With Passion

113. 0625\_p16\_qp\_20 Q: 8

Which statement about an object moving in a straight line through air is correct?

- A** When it accelerates, the resultant force acting on it is zero.  
**B** When it moves at a steady speed, the air resistance acting on it is zero.  
**C** When it moves at a steady speed, the resultant force acting on it is zero.  
**D** When it moves, there is a resultant force acting on it.

1.5. FORCES

114. 0625\_p16\_qp\_20 Q: 9

A beam pivoted at one end has a force of 5.0N acting vertically upwards on it as shown. The beam is in equilibrium.

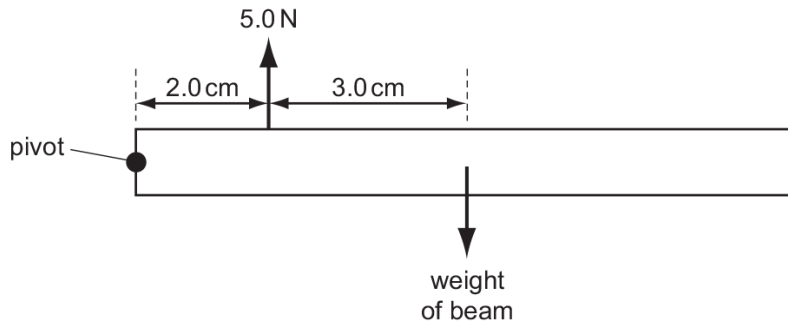

What is the weight of the beam?

- A** 2.0N      **B** 3.0N      **C** 3.3N      **D** 5.0N

115. 0625\_p16\_qp\_20 Q: 11

Which diagram shows two forces X and Y with their resultant force?

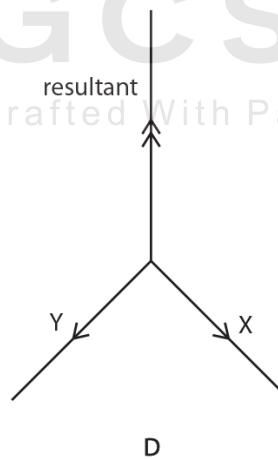
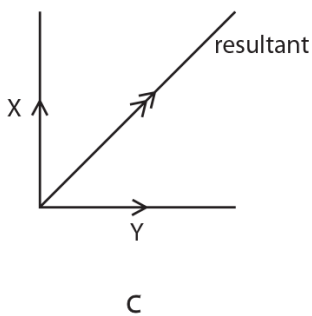
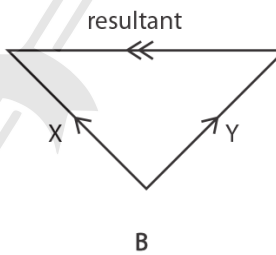
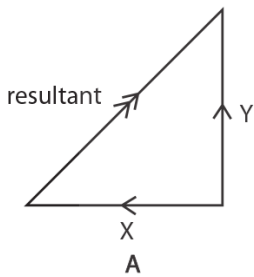

116. 0625\_s16\_qp\_21 Q: 4

A satellite orbits the Earth above the atmosphere at a constant speed.

The diagram shows the satellite at one point in its circular orbit around the Earth.

Which labelled arrow shows the direction of the resultant force on the satellite at the position shown?

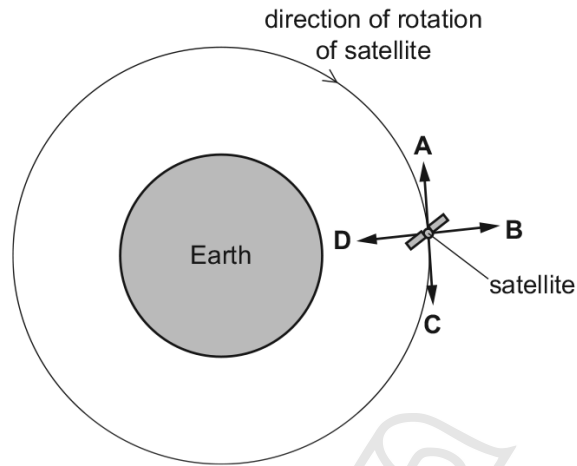

1.5. FORCES

117. 0625\_s16\_qp\_21 Q: 6

The diagrams show three uniform beams P, Q and R, each pivoted at its centre.

The two forces acting on each beam are also shown.

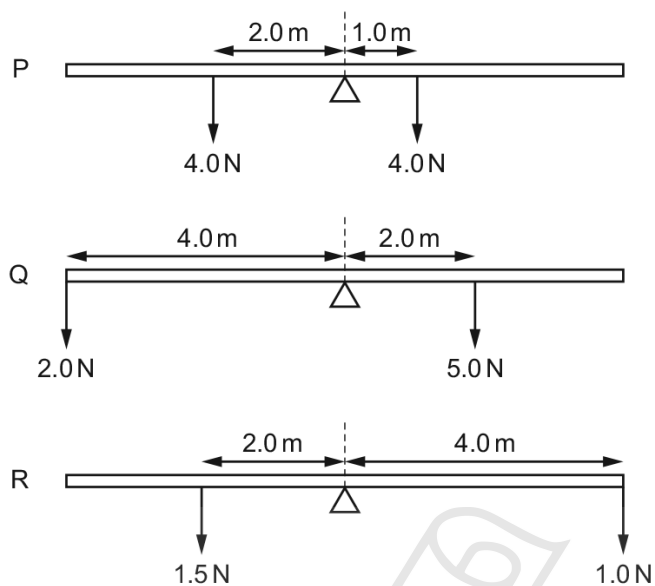

Which beams rotate clockwise?

- A P and Q only
- B P and R only
- C Q and R only
- D P, Q and R

118. 0625\_s16\_qp\_21 Q: 8

A scalar quantity has

- A magnitude and direction.
- B no magnitude and no direction.
- C magnitude but no direction.
- D direction but no magnitude.

119. 0625\_s16\_qp\_22 Q: 6

The diagram shows a non-uniform beam of weight 120 N, pivoted at one end. The beam is kept in equilibrium by force  $F$ .

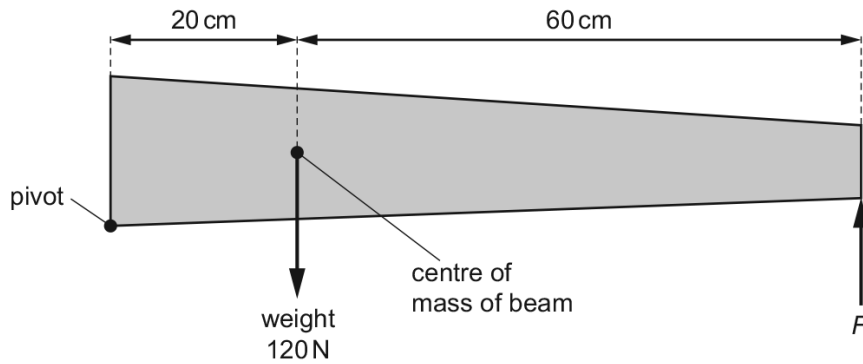

What is the value of force  $F$ ?

- A** 30 N      **B** 40 N      **C** 360 N      **D** 480 N

120. 0625\_s16\_qp\_22 Q: 7

An object is acted upon by a 3 N force and by a 4 N force.

Each diagram shows the two forces.

Which diagram also shows the resultant  $X$  of these two forces?

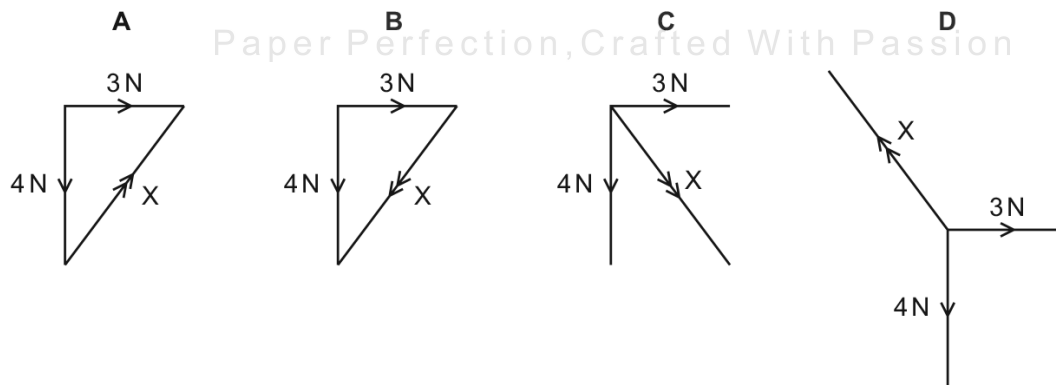

1.5. FORCES

121. 0625\_s16\_qp\_22 Q: 8

The engine of a car produces a driving force of 5000 N on the car. Resistive forces  $R$  also act on the car, as shown.

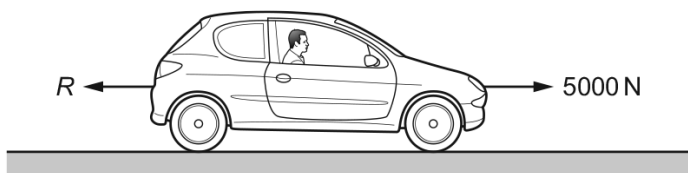

The car has a mass of 800 kg and an acceleration of  $1.0 \text{ m/s}^2$ .

What is the value of  $R$ ?

- A** 800 N      **B** 4200 N      **C** 5800 N      **D** 8000 N
- 

122. 0625\_s16\_qp\_23 Q: 5

An object moves in a circle at constant speed.

Which statement about the force needed on the object is correct?

- A** A force away from the centre of the circle keeps the object moving in the circle.  
**B** A force in the direction of motion of the object keeps it moving in the circle.  
**C** A force towards the centre of the circle keeps the object moving in the circle.  
**D** No force is needed to keep the object moving at constant speed in the circle.
- 

123. 0625\_s16\_qp\_23 Q: 6

A long plank  $XY$  lies on the ground. A load of 120 N is placed on it, at a distance of 0.50 m from end  $X$ , as shown.

End  $Y$  is lifted off the ground. The upward force needed to do this is 65 N.

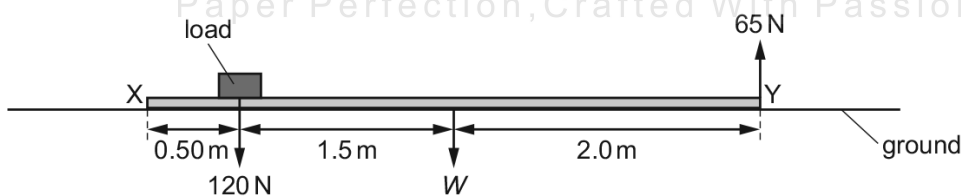

In the diagram,  $W$  is the weight of the plank, acting at its mid-point.

What is the value of  $W$ ?

- A** 35 N      **B** 47 N      **C** 100 N      **D** 133 N
-

124. 0625\_s16\_qp\_23 Q: 7

Which list contains only vector quantities?

- A energy, force, velocity
- B speed, acceleration, force
- C velocity, energy, acceleration
- D velocity, force, acceleration

125. 0625\_w16\_qp\_21 Q: 4

A spaceship approaches the Earth from deep space. Near the Earth, a force on the spaceship causes it to have weight. This causes it to change its speed and direction.

Which type of force causes the spaceship's weight, and which property of the spaceship resists its change in speed and direction?

	force that causes weight	property that resists change in speed and direction
A	gravitational	mass
B	gravitational	volume
C	magnetic	mass
D	magnetic	volume

126. 0625\_w16\_qp\_21 Q: 7

Which diagram shows the magnitude and direction of the resultant  $R$  of the two forces  $F_1$  and  $F_2$ ?

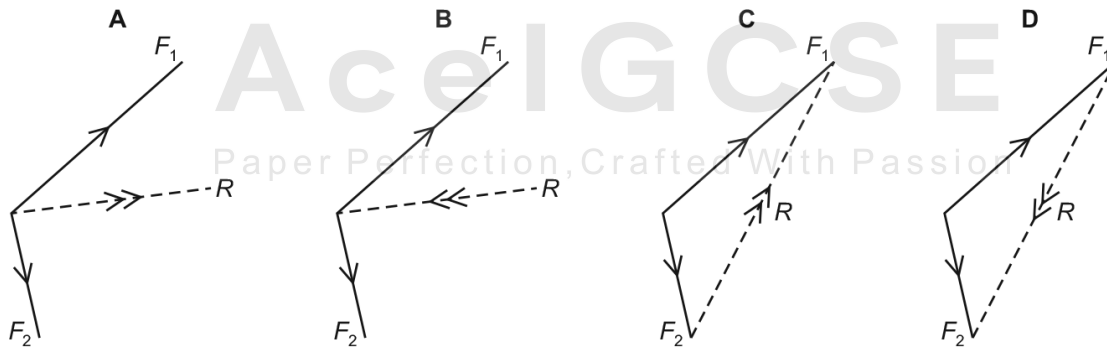

1.5. FORCES

127. 0625\_w16\_qp\_22 Q: 7

The diagrams show a spring and a graph of the length of the spring against the load applied to it.

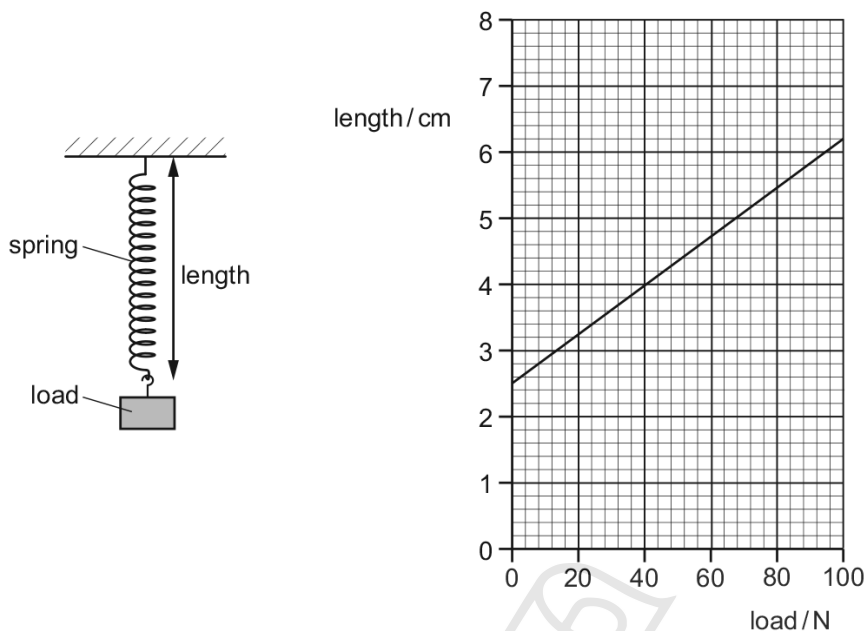

What is the extension of the spring when a load of 40 N is applied to it?

- A** 1.5 cm      **B** 2.5 cm      **C** 4.0 cm      **D** 6.5 cm

128. 0625\_w16\_qp\_23 Q: 7

Different loads are hung on a spring. The diagram shows the length of the spring with and without the loads attached.

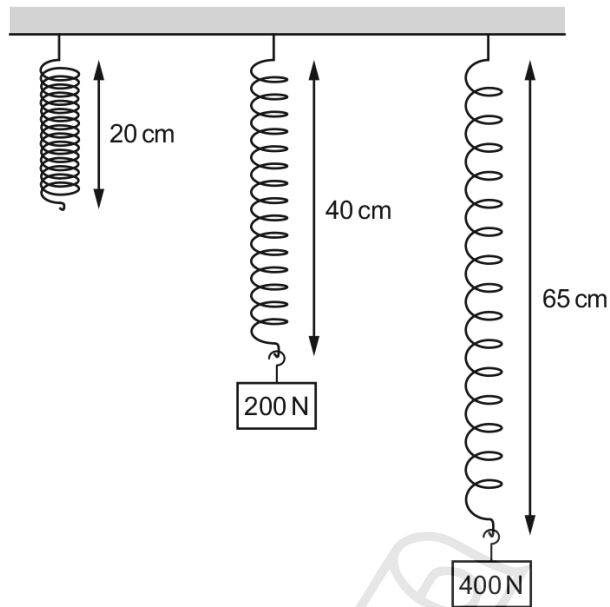

What is the extension of the spring when the load is 400 N?

- A** 5 cm      **B** 25 cm      **C** 40 cm      **D** 45 cm

129. 0625\_m15\_qp\_12 Q: 6

The diagram shows the only three forces acting on an object.



What is the resultant force on the object?

- A** 0 N  
**B** 5.0 N towards the left  
**C** 5.0 N towards the right  
**D** 10.0 N towards the right

1.5. FORCES

130. 0625\_m15\_qp\_12 Q: 7

A uniform rod rests on a pivot at its centre. The rod is not attached to the pivot. Forces are then applied to the rod in four different ways, as shown. The weight of the rod can be ignored.

Which diagram shows the rod in equilibrium?

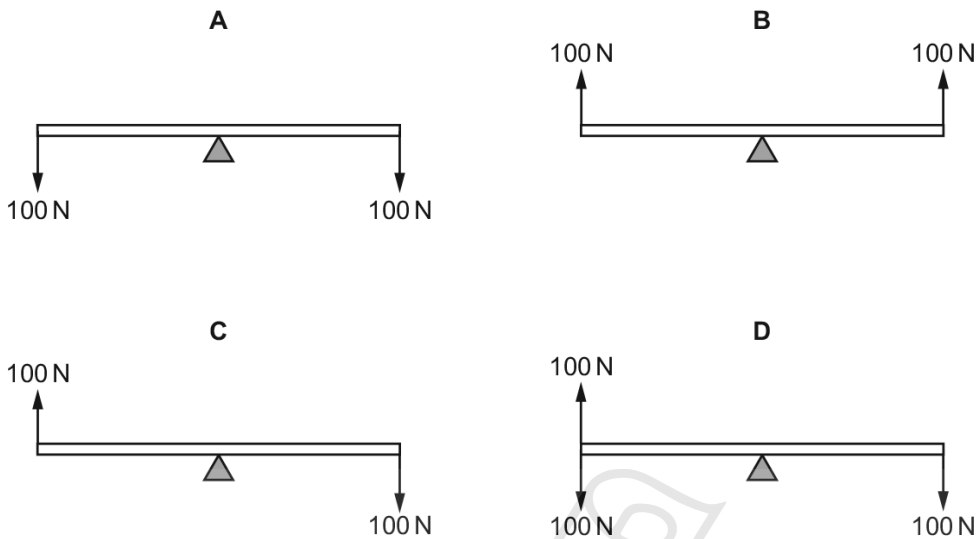

131. 0625\_s15\_qp\_11 Q: 6

Four objects are each acted on by only two forces, as shown.

Which object is in equilibrium?

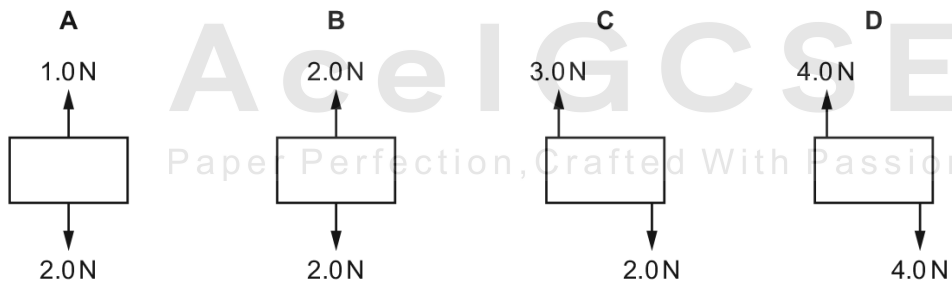

132. 0625\_s15\_qp\_11 Q: 7

A student measures the length of a spring. She then hangs different weights from the spring. She measures the length of the spring for each different weight.

The table shows her results.

weight / N	length / mm
0	520
1.0	524
2.0	528
3.0	533
4.0	537
5.0	540

What is the extension of the spring when the weight hung from it is 3.0 N?

- A** 4 mm      **B** 5 mm      **C** 12 mm      **D** 13 mm

133. 0625\_s15\_qp\_12 Q: 4

The diagram shows a uniform beam being used as a balance. The beam is pivoted at its centre.

A 1.0 N weight is attached to one end of the beam. An empty pan weighing 0.2 N is attached to the other end of the beam.

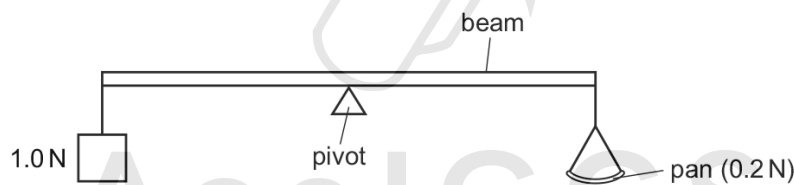

How many 0.1 N weights must be placed on the pan in order to balance the beam?

- A** 5      **B** 8      **C** 10      **D** 12

1.5. FORCES

134. 0625\_s15\_qp\_12 Q: 6

The diagrams show four identical objects. Each object is acted on by only the three forces shown.

Which object accelerates to the right, with the **smallest** acceleration?

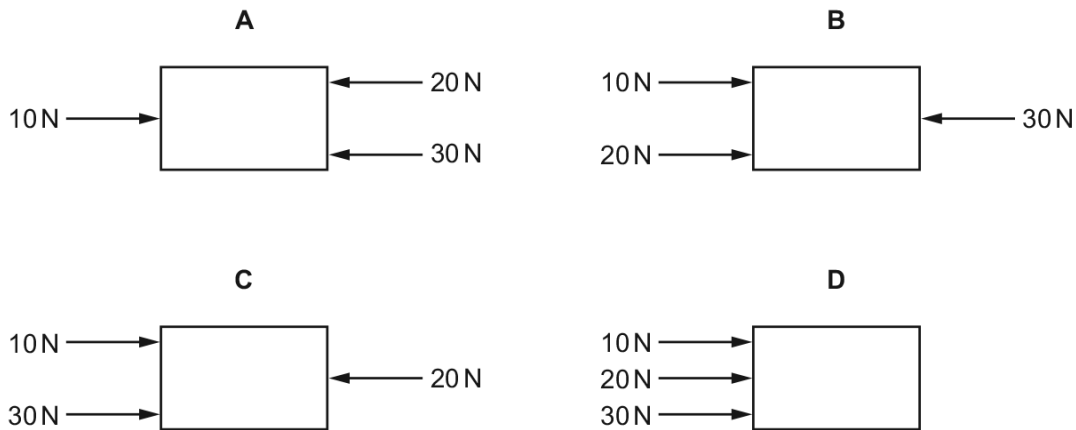

135. 0625\_s15\_qp\_12 Q: 7

Different weights are hung from a spring. The diagram shows the original length of the spring, and the lengths when different weights are added.

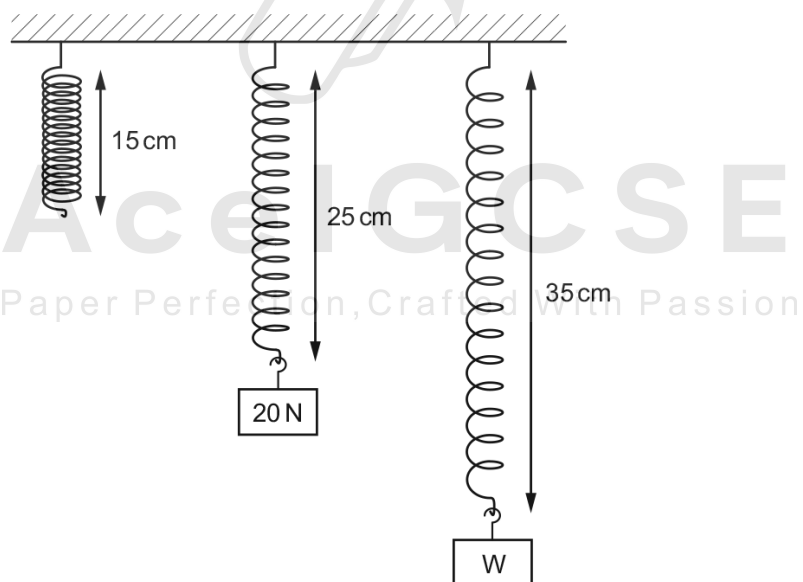

The extension of the spring is directly proportional to the weight hung from it.

What is the weight of W?

- A** 30 N      **B** 35 N      **C** 40 N      **D** 45 N

136. 0625\_s15\_qp\_13 Q: 4

Weight is an example of which quantity?

- A acceleration
  - B force
  - C mass
  - D pressure
- 

137. 0625\_s15\_qp\_13 Q: 6

A car travels along a horizontal road at a constant speed. Three horizontal forces act on the car. The diagram shows two of these three forces.

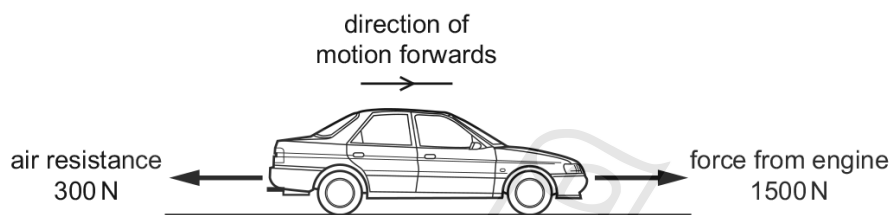

What is the size and the direction of the third horizontal force acting on the car?

- A 1200 N backwards
  - B 1200 N forwards
  - C 1800 N backwards
  - D 1800 N forwards
- 

**AceIGCSE**  
Paper Perfection, Crafted With Passion

1.5. FORCES

138. 0625\_s15\_qp\_13 Q: 7

The extension-load graph for a spring is shown. The unstretched length of the spring is 17.0 cm.

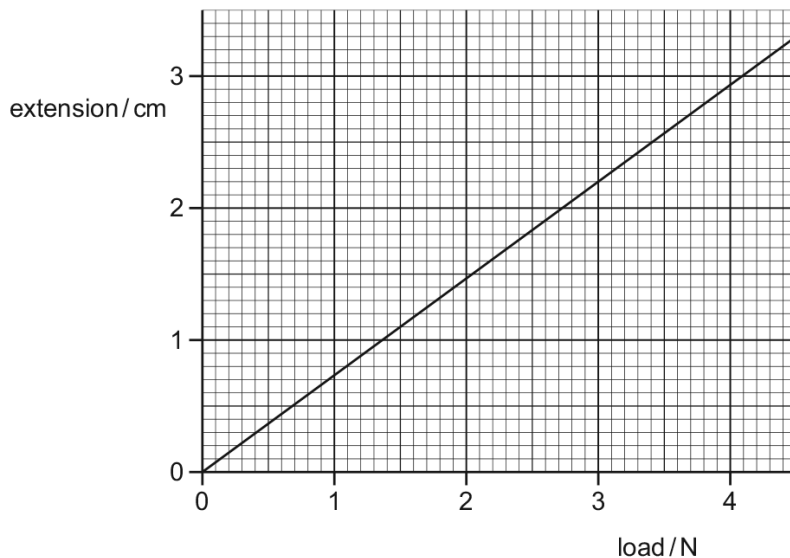

When an object is hung from the spring, the length of the spring is 19.2 cm.

What is the weight of the object?

- A** 1.4 N      **B** 1.6 N      **C** 2.6 N      **D** 3.0 N

139. 0625\_w15\_qp\_11 Q: 6

A heavy beam rests on two supports. The diagram shows the only three forces  $F_1$ ,  $F_2$  and  $F_3$  acting on the beam.

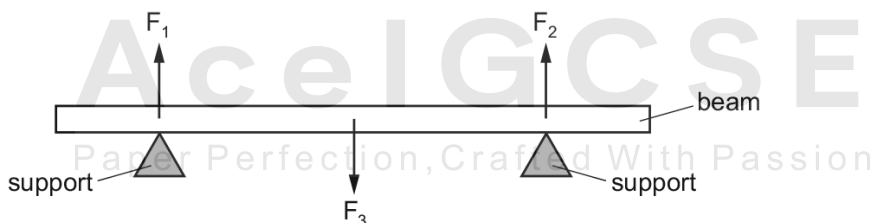

The beam is in equilibrium.

Which statement is correct?

- A** All the forces are equal in size.  
**B** The resultant force on the beam is in the opposite direction to the resultant turning effect.  
**C** The resultant force on the beam is zero and the resultant turning effect on the beam is zero.  
**D** The total upward force is twice the total downward force.

140. 0625\_w15\_qp\_11 Q: 7

Which list contains only properties of an object that can be changed by a force?

- A direction of motion, mass, shape
- B direction of motion, mass, speed
- C direction of motion, shape, speed
- D mass, shape, speed

141. 0625\_w15\_qp\_12 Q: 7

The diagrams show four solid cones. The centre of mass of each cone is marked by a point labelled M.

Which cone is the most stable?

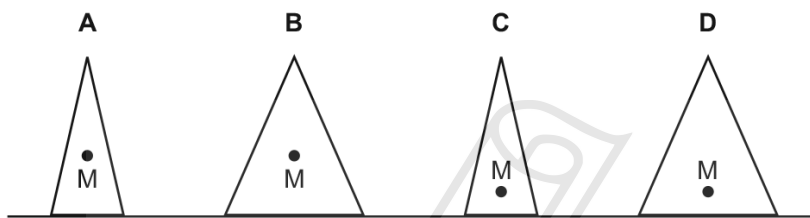

142. 0625\_w15\_qp\_13 Q: 7

A heavy truck on wheels has a platform attached to it.

A man stands on the platform.

The truck does not fall over.

Which position **A**, **B**, **C** or **D** could be the centre of mass of the whole system (truck, platform and man)?

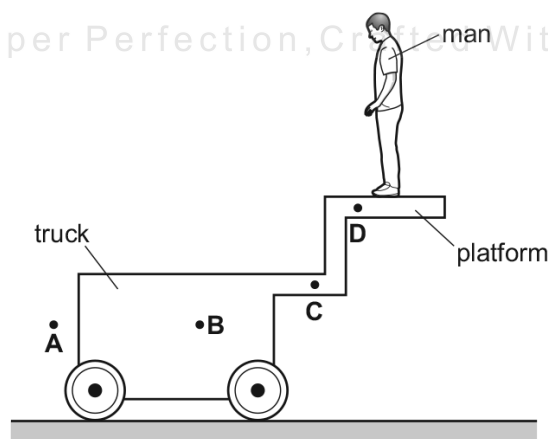

1.5. FORCES

143. 0625\_s14\_qp\_11 Q: 6

A plane lamina with centre of mass  $X$  touches the ground at point  $P$ .

Which diagram shows the lamina in equilibrium?

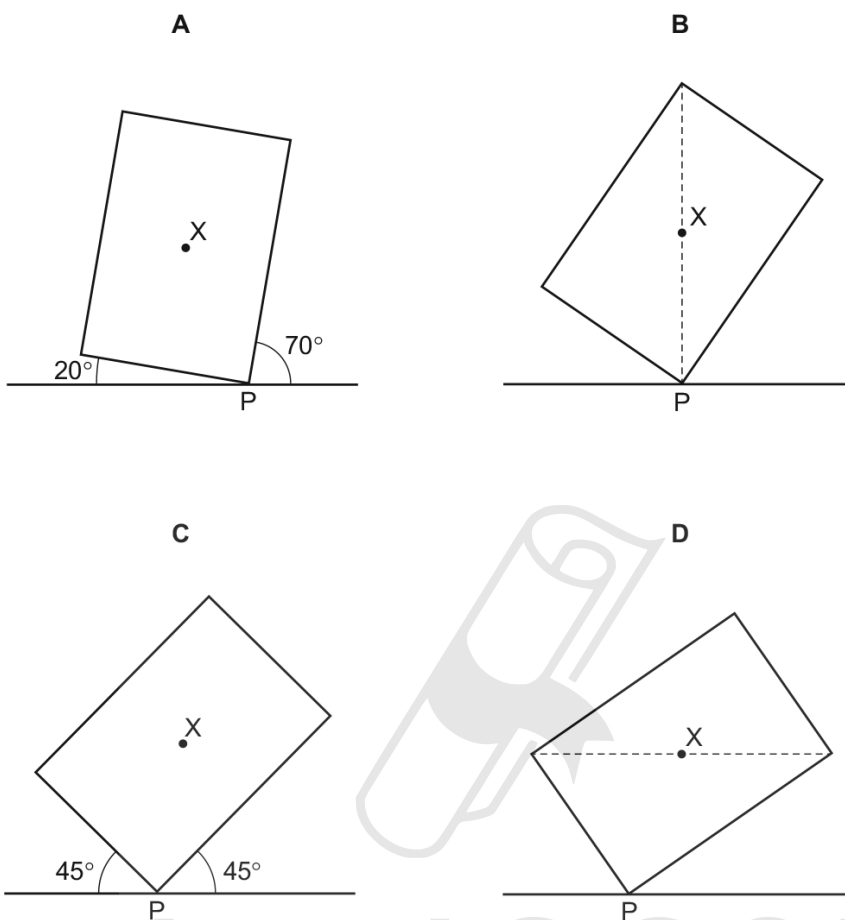

AceIGCSE

Paper Perfection. Crafted With Passion.

144. 0625\_s14\_qp\_11 Q: 7

A student adds weights to an elastic cord. He measures the length of the cord for each weight.

He then plots a graph from the results, as shown.

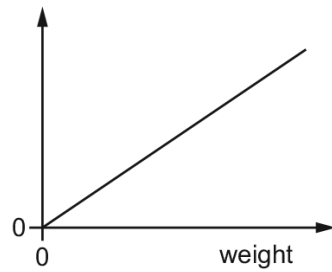

What has he plotted on the vertical axis?

- A measured length
- B original length
- C (measured length + original length)
- D (measured length – original length)

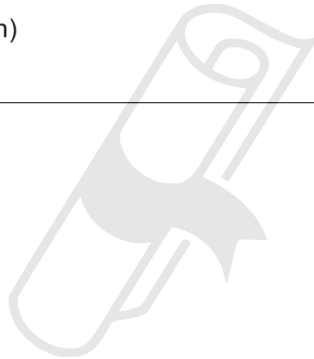

**AceIGCSE**  
Paper Perfection, Crafted With Passion

1.5. FORCES

145. 0625\_s14\_qp\_12 Q: 6

A wooden bar is pivoted at its centre so that it can rotate freely. Two equal forces  $F$  are applied to the bar.

In which diagram is the turning effect greatest?

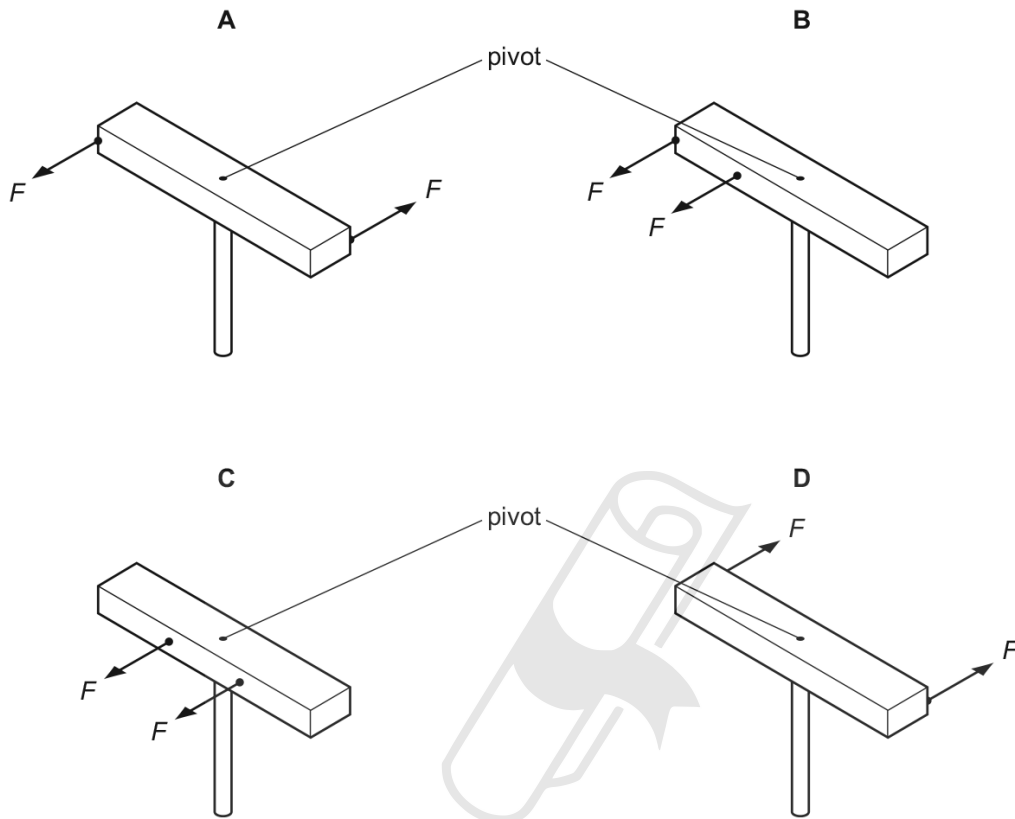

146. 0625\_w14\_qp\_11 Q: 7

In which situation is **no** resultant force needed?

- A a car changing direction at a steady speed
- B a car moving in a straight line at a steady speed
- C a car slowing down
- D a car speeding up

147. 0625\_w14\_qp\_11 Q: 8

Which properties of a body can be changed by applying a force to the body?

- A mass, motion and shape
  - B mass and motion, but not shape
  - C mass and shape, but not motion
  - D motion and shape, but not mass
- 

148. 0625\_w14\_qp\_13 Q: 8

The diagram shows a uniform, flat metal sheet hanging freely from a nail at point **A**. A weight also hangs freely on a string tied to **A**.

One of the labelled points is at the centre of mass of the metal sheet.

Which point is at the centre of mass?

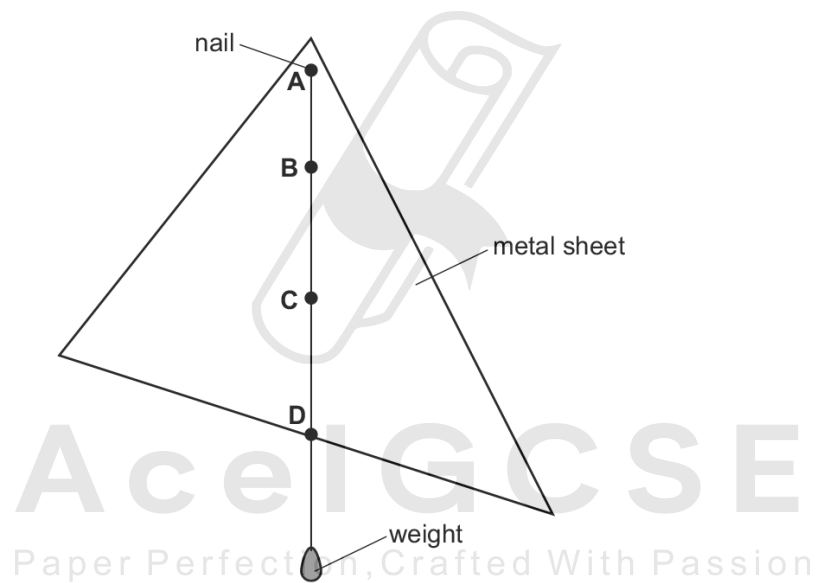

### 1.5. FORCES

149. 0625\_s13\_qp\_11 Q: 7

A car moves along a level road.

The diagram shows all of the horizontal forces acting on the car.

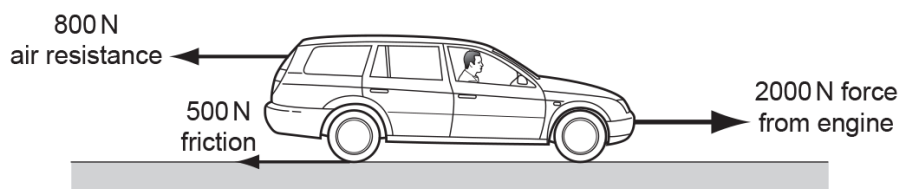

Which statement is correct?

- A The car is slowing down.
- B The car is speeding up.
- C The car is moving at a constant speed.
- D The car is moving backwards.

---

150. 0625\_s13\_qp\_11 Q: 8

The diagram shows a force being applied to a lever to lift a heavy weight.

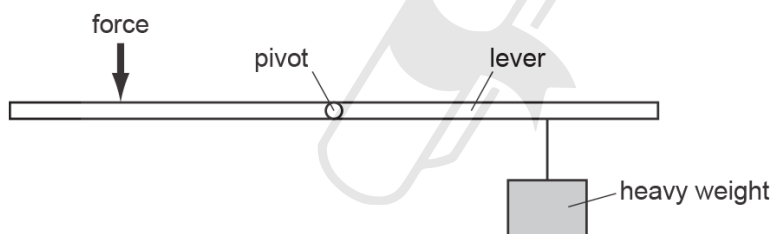

Which change would enable the heavy weight to be lifted with a smaller force?

- A Move the force to the right.
- B Move the heavy weight to the right.
- C Move the force to the left.
- D Move the pivot to the left.

151. 0625\_s13\_qp\_12 Q: 8

The diagrams show different objects, each being acted upon by only the two forces shown.

Which object is in equilibrium?

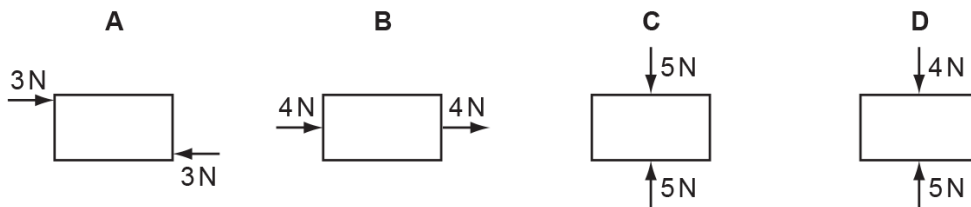

152. 0625\_w13\_qp\_11 Q: 7

A force acting on an object causes some properties of the object to change.

Which list contains **only** properties that can be changed by the action of the force?

- A mass, motion and shape
- B mass, motion and size
- C mass, shape and size
- D motion, shape and size

153. 0625\_w13\_qp\_11 Q: 8

A box is being moved by a fork-lift truck. The total weight of the box is 3000 N.



The force exerted by the fork-lift truck on the box is 3500 N upwards.

What is the resultant force on the box?

- A 500 N downwards
- B 500 N upwards
- C 6500 N downwards
- D 6500 N upwards

1.5. FORCES

154. 0625\_w13\_qp\_13 Q: 4

Which is the unit for force and which is the unit for weight?

	force	weight
<b>A</b>	kg	kg
<b>B</b>	kg	N
<b>C</b>	N	kg
<b>D</b>	N	N

155. 0625\_w13\_qp\_13 Q: 7

The diagrams show a steel spring and a graph of its length against the load applied to it.

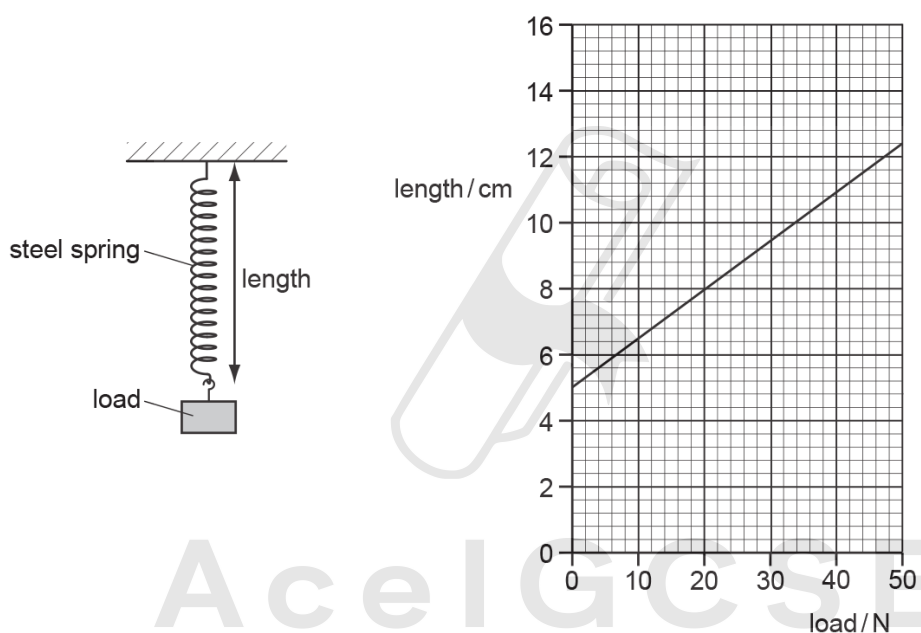

What is the extension of the spring when a load of 20N is applied to it?

- A** 3.0 cm      **B** 4.5 cm      **C** 5.0 cm      **D** 8.0 cm

156. 0625\_s12\_qp\_11 Q: 7

Passengers are **not** allowed to stand on the upper deck of double-decker buses.

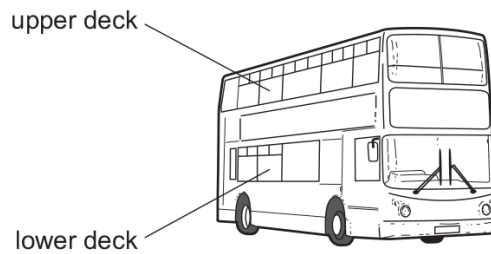

Why is this?

- A They would cause the bus to become less stable.
- B They would cause the bus to slow down.
- C They would increase the kinetic energy of the bus.
- D They would lower the centre of mass of the bus.

157. 0625\_s12\_qp\_11 Q: 8

The diagram shows a handle with three forces, each 100 N, applied to it. The handle is free to move.

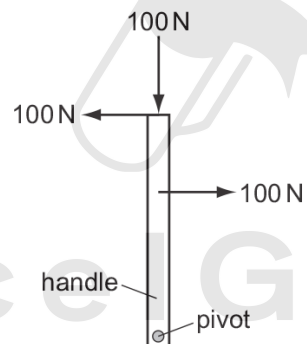

What is the effect of the forces on the handle?

- A The handle will move downwards.
- B The handle will not move.
- C The handle will turn anticlockwise (to the left).
- D The handle will turn clockwise (to the right).

1.5. FORCES

158. 0625\_s12\_qp\_12 Q: 8

On which ball is a non-zero resultant force acting?

**A**

a ball moving at constant speed on a smooth surface

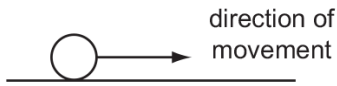

**B**

a ball at rest on a bench



**C**

a free-falling ball which has just been released

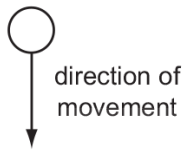

**D**

a ball floating on water

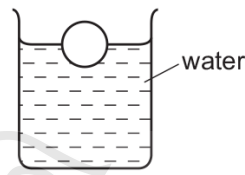

159. 0625\_w12\_qp\_11 Q: 7

The diagram shows sections of four objects of equal mass. The position of the centre of mass of each object has been marked with a cross.

Which object is the most stable?

**A**

**B**

**C**

**D**

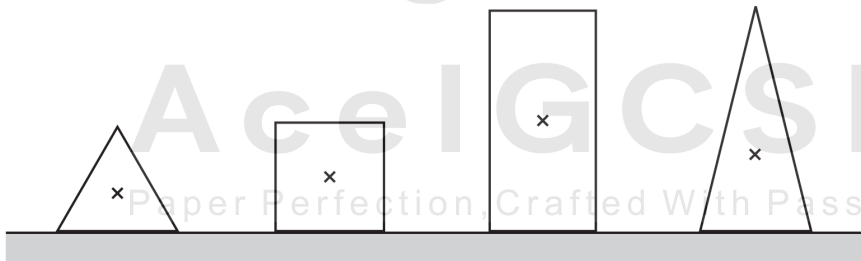

160. 0625\_w12\_qp\_11 Q: 8

A see-saw is made by resting a long plank of wood with its centre of mass on a barrel.

A boy sits on one side of the barrel and a girl sits on the other side so that the see-saw is balanced.

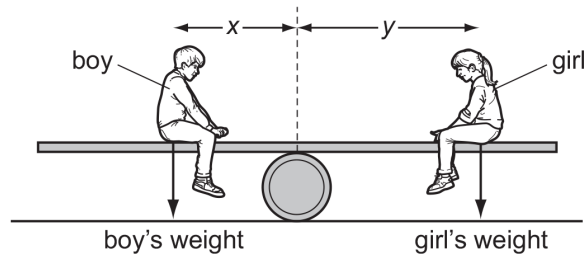

Which statement **must** be true?

- A boy's weight = girl's weight
- B distance  $x$  = distance  $y$
- C total downward force = total moment about the barrel
- D resultant force and resultant moment are both zero

161. 0625\_w12\_qp\_13 Q: 8

A large parcel is on a horizontal conveyor belt. The conveyor belt moves the parcel towards a lorry.

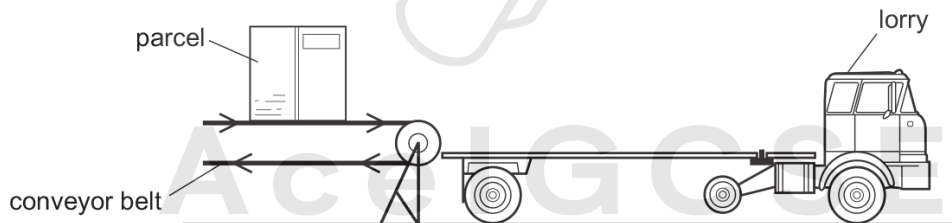

The parcel travels towards the lorry at a constant speed. Only two horizontal forces act on the parcel: air resistance, and friction with the conveyor belt.

Which row correctly compares the directions and the sizes of these two forces?

	directions	sizes
<b>A</b>	opposite	different
<b>B</b>	opposite	the same
<b>C</b>	the same	different
<b>D</b>	the same	the same

SN	Paper	Q. No.	Answer
01	0625_s12_qp_11	6	D
02	0625_w12_qp_11	6	C
03	0625_m22_qp_22	6	C
04	0625_m22_qp_22	7	C
05	0625_m22_qp_22	8	D
06	0625_m22_qp_22	9	D
07	0625_m22_qp_22	10	B
08	0625_m21_qp_22	6	A
09	0625_m21_qp_22	7	C
10	0625_m21_qp_22	8	C
11	0625_s21_qp_21	6	D
12	0625_s21_qp_21	7	D
13	0625_s21_qp_22	7	D
14	0625_s21_qp_23	6	D
15	0625_s21_qp_23	7	C
16	0625_w21_qp_21	5	C
17	0625_w21_qp_21	6	B
18	0625_w21_qp_22	5	A
19	0625_w21_qp_22	6	B
20	0625_w21_qp_23	5	A
21	0625_w21_qp_23	6	B
22	0625_m20_qp_22	7	A
23	0625_m20_qp_22	8	C
24	0625_m20_qp_22	9	C
25	0625_p20_qp_20	6	B
26	0625_p20_qp_20	7	B
27	0625_p20_qp_20	8	C
28	0625_p20_qp_20	9	A
29	0625_p20_qp_20	11	C
30	0625_s20_qp_21	4	C
31	0625_s20_qp_21	7	C
32	0625_s20_qp_21	8	A
33	0625_s20_qp_21	9	A
34	0625_s20_qp_22	7	B
35	0625_s20_qp_22	8	C
36	0625_s20_qp_23	7	B
37	0625_s20_qp_23	8	B
38	0625_w20_qp_21	7	A
39	0625_w20_qp_21	8	B
40	0625_w20_qp_21	10	C
41	0625_w20_qp_22	3	C
42	0625_w20_qp_22	7	A
43	0625_w20_qp_22	8	B
44	0625_w20_qp_23	7	C
45	0625_w20_qp_23	8	B
46	0625_m19_qp_22	7	C
47	0625_m19_qp_22	8	B
48	0625_m19_qp_22	9	B
49	0625_s19_qp_21	6	D

SN	Paper	Q. No.	Answer
50	0625_s19_qp_21	7	C
51	0625_s19_qp_21	8	B
52	0625_s19_qp_22	6	B
53	0625_s19_qp_22	7	B
54	0625_s19_qp_22	8	C
55	0625_s19_qp_23	4	D
56	0625_s19_qp_23	6	D
57	0625_s19_qp_23	7	D
58	0625_s19_qp_23	8	B
59	0625_w19_qp_21	6	B
60	0625_w19_qp_21	7	D
61	0625_w19_qp_21	8	C
62	0625_w19_qp_22	4	A
63	0625_w19_qp_22	6	C
64	0625_w19_qp_22	7	D
65	0625_w19_qp_22	8	C
66	0625_w19_qp_23	5	B
67	0625_w19_qp_23	7	D
68	0625_w19_qp_23	8	C
69	0625_m18_qp_22	4	D
70	0625_m18_qp_22	8	D
71	0625_m18_qp_22	9	B
72	0625_s18_qp_21	6	A
73	0625_s18_qp_21	7	B
74	0625_s18_qp_21	8	B
75	0625_s18_qp_22	6	C
76	0625_s18_qp_22	7	D
77	0625_s18_qp_22	8	B
78	0625_s18_qp_23	6	A
79	0625_s18_qp_23	7	B
80	0625_s18_qp_23	8	D
81	0625_w18_qp_21	4	D
82	0625_w18_qp_21	7	A
83	0625_w18_qp_22	6	D
84	0625_w18_qp_22	7	A
85	0625_w18_qp_23	6	D
86	0625_w18_qp_23	7	C
87	0625_m17_qp_22	6	A
88	0625_m17_qp_22	7	C
89	0625_s17_qp_21	3	B
90	0625_s17_qp_21	6	D
91	0625_s17_qp_21	7	C
92	0625_s17_qp_21	8	B
93	0625_s17_qp_22	4	B
94	0625_s17_qp_22	6	B
95	0625_s17_qp_22	7	C
96	0625_s17_qp_22	8	A
97	0625_s17_qp_23	6	B
98	0625_s17_qp_23	7	B

SN	Paper	Q. No.	Answer
99	0625_s17_qp_23	8	D
100	0625_w17_qp_21	6	C
101	0625_w17_qp_21	7	B
102	0625_w17_qp_21	8	C
103	0625_w17_qp_22	6	C
104	0625_w17_qp_22	7	C
105	0625_w17_qp_23	3	A
106	0625_w17_qp_23	6	D
107	0625_w17_qp_23	7	D
108	0625_m16_qp_22	6	B
109	0625_m16_qp_22	7	A
110	0625_m16_qp_22	8	C
111	0625_p16_qp_20	6	B
112	0625_p16_qp_20	7	B
113	0625_p16_qp_20	8	C
114	0625_p16_qp_20	9	A
115	0625_p16_qp_20	11	C
116	0625_s16_qp_21	4	D
117	0625_s16_qp_21	6	C
118	0625_s16_qp_21	8	C
119	0625_s16_qp_22	6	A
120	0625_s16_qp_22	7	C
121	0625_s16_qp_22	8	B
122	0625_s16_qp_23	5	C
123	0625_s16_qp_23	6	C
124	0625_s16_qp_23	7	D
125	0625_w16_qp_21	4	A
126	0625_w16_qp_21	7	A
127	0625_w16_qp_22	7	A
128	0625_w16_qp_23	7	D
129	0625_m15_qp_12	6	A
130	0625_m15_qp_12	7	A
131	0625_s15_qp_11	6	B
132	0625_s15_qp_11	7	D
133	0625_s15_qp_12	4	B
134	0625_s15_qp_12	6	C
135	0625_s15_qp_12	7	C
136	0625_s15_qp_13	4	B
137	0625_s15_qp_13	6	A
138	0625_s15_qp_13	7	D
139	0625_w15_qp_11	6	C
140	0625_w15_qp_11	7	C
141	0625_w15_qp_12	7	D
142	0625_w15_qp_13	7	B
143	0625_s14_qp_11	6	B
144	0625_s14_qp_11	7	D
145	0625_s14_qp_12	6	A
146	0625_w14_qp_11	7	B
147	0625_w14_qp_11	8	D

SN	Paper	Q. No.	Answer
148	0625_w14_qp_13	8	C
149	0625_s13_qp_11	7	B
150	0625_s13_qp_11	8	C
151	0625_s13_qp_12	8	C
152	0625_w13_qp_11	7	D
153	0625_w13_qp_11	8	B
154	0625_w13_qp_13	4	D
155	0625_w13_qp_13	7	A
156	0625_s12_qp_11	7	A
157	0625_s12_qp_11	8	C
158	0625_s12_qp_12	8	C
159	0625_w12_qp_11	7	A
160	0625_w12_qp_11	8	D
161	0625_w12_qp_13	8	B

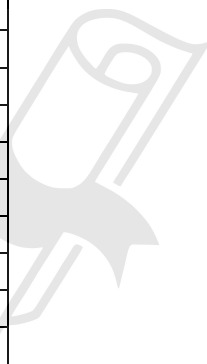

AcelGCSE  
Perfection, Crafted With Passion